

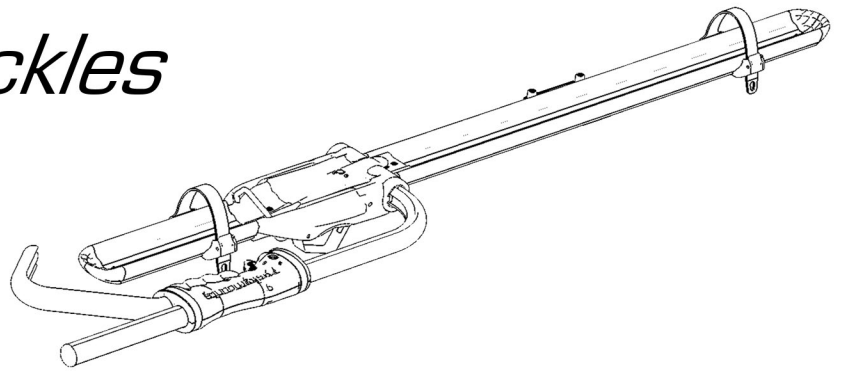

rockymounts
BrassKnuckles



Guidelines

- Minimum crossbar spread: 24" (61cm). Maximum crossbar spread: 43" (110cm)
- Bicycle weight limit = 45lbs (21kg) on RockyMounts®, Thule®, or Yakima Bars®, 35lbs (16kg) on factory crossbars
- 2 bicycle maximum on factory crossbars
- 20"-29" wheels only. Fits up to 3" tires. (Fits up to 5" tires with fat bike adapter)
- Fat Bikes require the BrassKnuckles Fat Bike Kit
- Remove front fenders, racks, panniers before use
- Install as roof rack only
- No electric bikes, kick bikes, recumbents, mopeds, scooters, pennyfarthings, tandems, or bikes with 48" (122cm), wheelbase or greater

Parts Included

A: Load Arm Assembly

C: End Cap

E: M6x22 Bolt

B: Rear Tray with Mounting Bracket

D: Wheel Strap Assembly

F: 5mm Ball End Hex Key

Note: Rack is configured for installation on the driver's side. For passenger side installation, you will need to remove the arm assembly and reverse, follow steps at "Passenger Side Configuration".

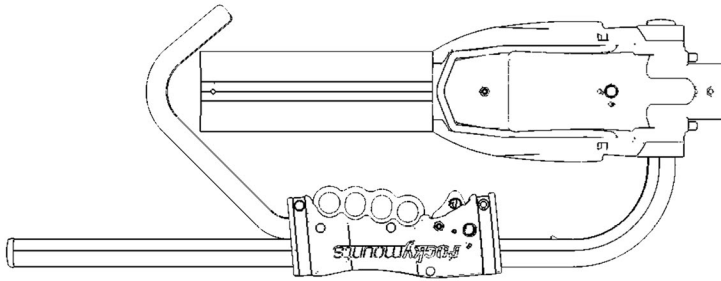

A (1x)

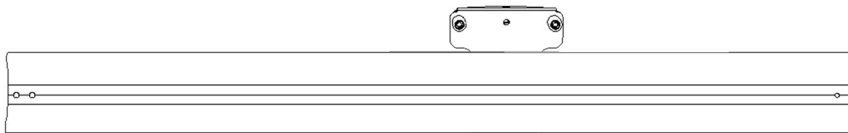

B (1x)

*Locks Not Included



C (2x)



D (2x)



E (2x)

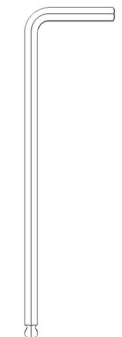

F (1x)

Installation Instructions

1 Install Rear Tray

Insert arm assembly into rear tray. Install two M6x22 bolts through plate and tray

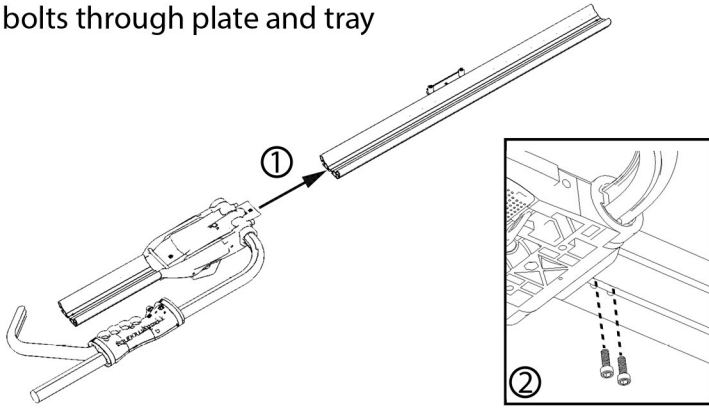

2 Remove Top Cap

Pull on the tab and remove cap

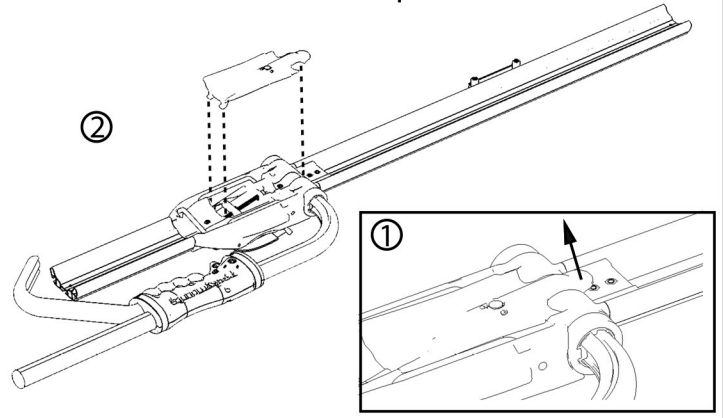

3 Loosen Straps & Mounting Bracket

Turn bolt counterclockwise to loosen mounting straps. Loosen mounting bracket to install onto cross bar

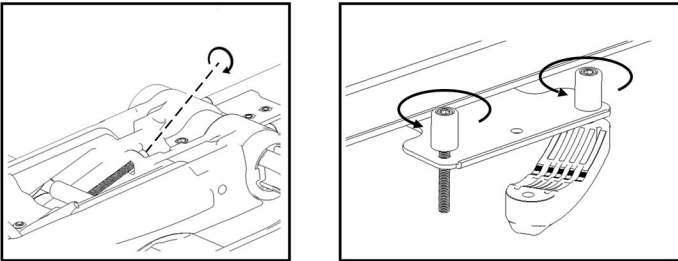

4 Position & Install Rack

Place head onto front crossbar. Slide rear plate above rear crossbar. FIRST: Reattach straps around front crossbar. NEXT: Tighten M6 bolt with 5mm hex key. Tighten two bolts on rear bracket

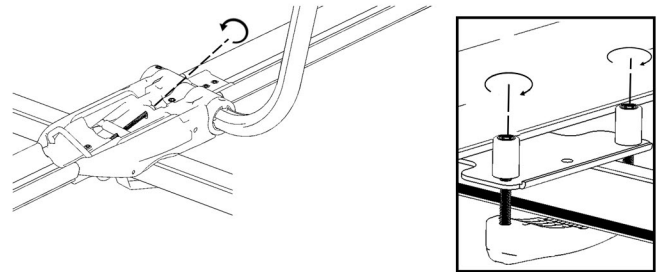

5 Install Wheel Straps

Slide wheel straps onto wheel tray with buckles facing out

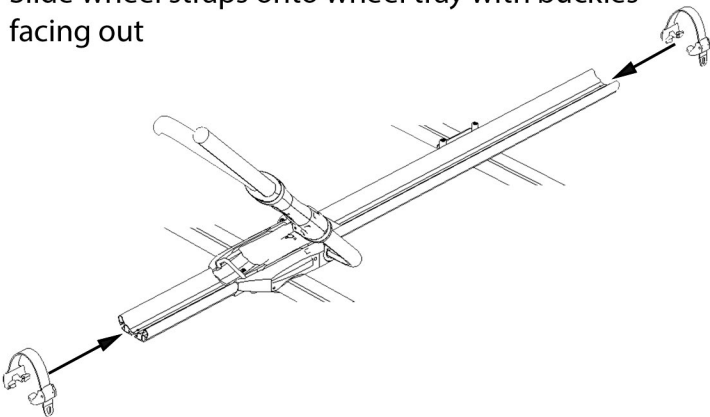

6 End Caps & Top Cap

Install end caps onto trays. Reinstall top cap

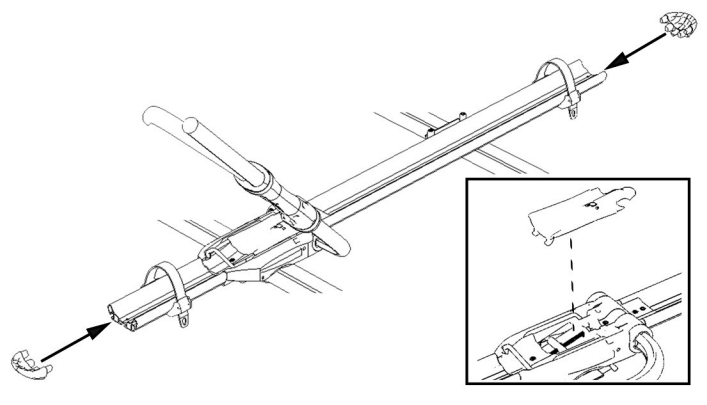

Loading Bike

1 Loading Preparation

Fully extend load arm hook. Fully open back stop.
Tuck wheel straps

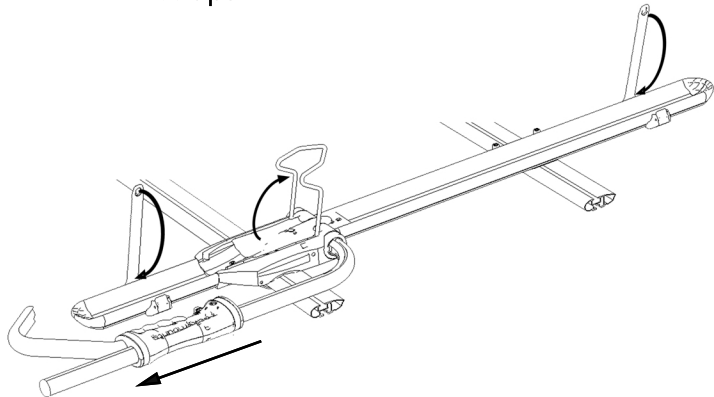

2 Place Bike on Rack

Load bike on wheel tray. **FRONT WHEEL SHOULD BE SECURE AGAINST BACK STOP**

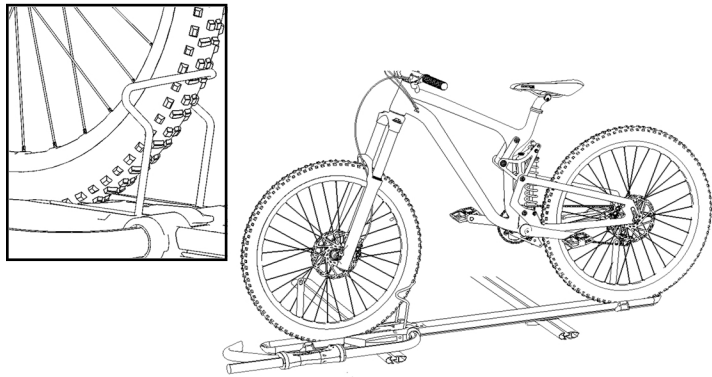

3 Secure Front Wheel

Rotate load arm over front wheel and tighten hook with **MINIMUM GAP** between fork

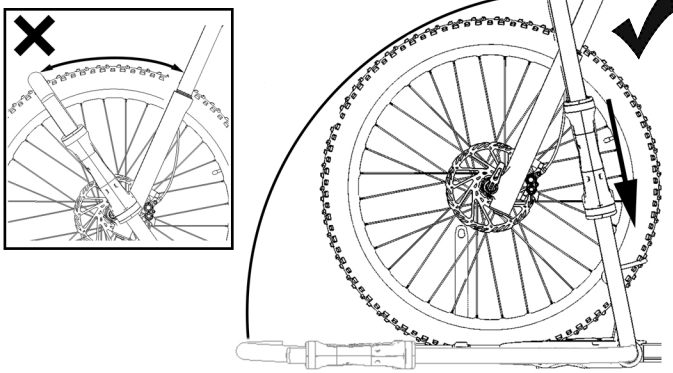

4 Tighten Wheel Straps

For both wheels: feed wheel strap through wheel and into buckle. Test bike by shaking

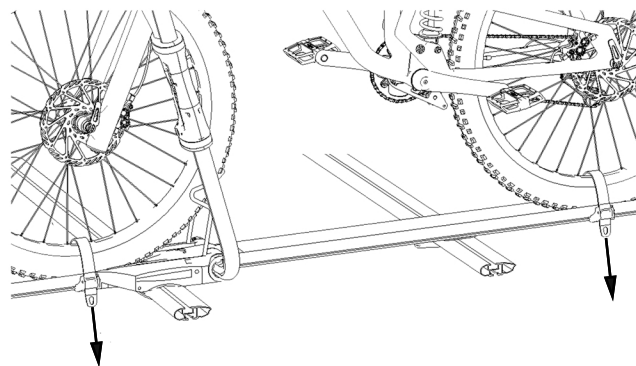

Lock Core Installation Instructions

1 Pry Off Lock Cap

Pry off plastic cap on top cap using a flat head screwdriver

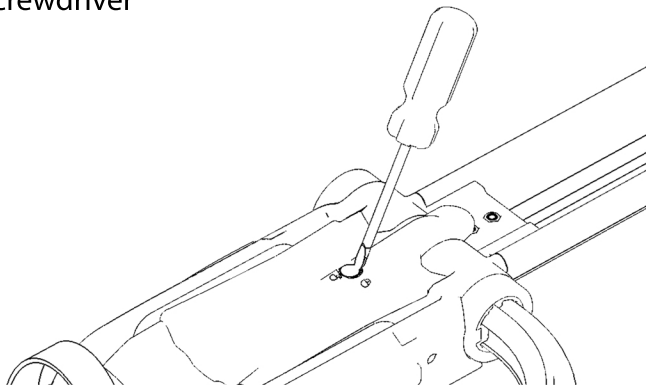

2 Install Lock Core

Insert key into core and line up large protruding metal wafer between tabs in housing. Install lock cores, turn key to "lock" position and pull key out

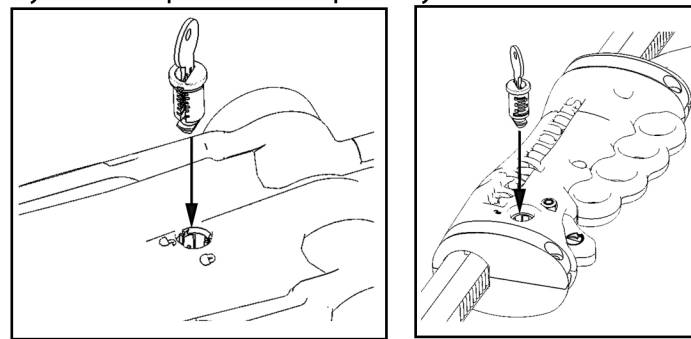

Passenger Side Installation Instructions

1 Remove Collar

Remove top cap. Rotate load arm to show bolt on collar. Remove bolt and pry off collar

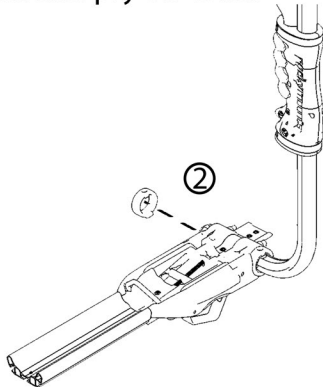
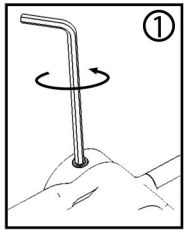

2 Remove Load Arm

Loosen bolt and slide load arm out

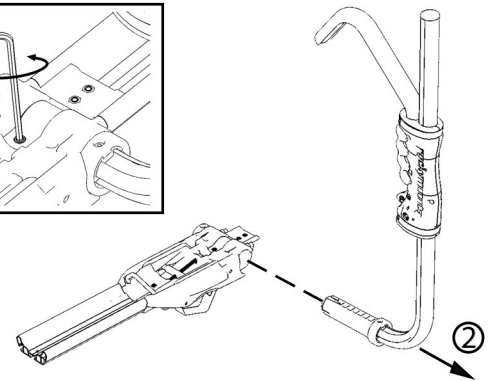
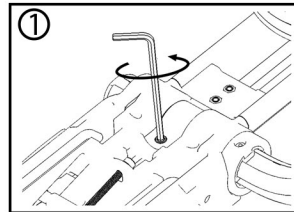

3 Flip Load Arm

Flip load arm and reinstall from the other direction. Install collar and retighten two M6 bolts

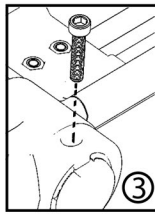
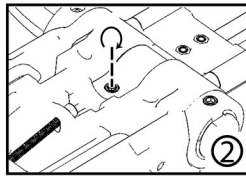
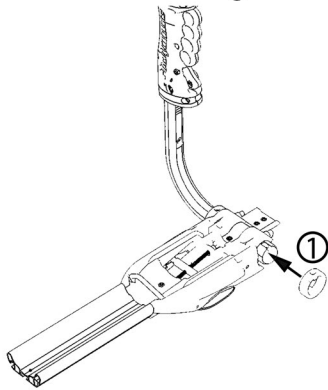

4 Mounting

Flip mounting plate on wheel tray

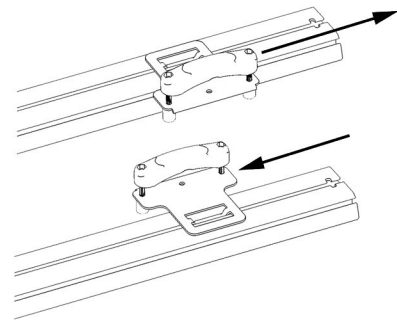

Follow Step 1 to Step 6 on Page 1 to mount rack onto vehicle

Warnings

- Remove Baby Seats, Panniers, U-Locks, or items that could detach from the bicycle.
- Do not use bicycle covers, bicycle bras, or bikes equipped with rear disc wheel.
- Not intended for off road use. Not intended for use on trailers or towed vehicles.
- Locks are only deterrents to thieves, RockyMounts, Inc. cannot be held liable for stolen bicycles.
- Remove rack before entering a car wash.
- Check all fastenings (nuts, bolts, straps, and skewer) before each use.
- Once a year, remove rack from car. Clean and inspect for damage.
- Do not mount vertically

Lifetime Warranty

Thank you for purchasing a RockyMounts product. We take pride in providing a great customer experience and manufacturing products that enable our customers to get their gear to their next colorful adventure.

As of January 1, 2014, RockyMounts products are covered for life to the original purchaser when used in accordance with the instruction manuals' assembly, installation and use guidelines.

If you feel something broke before it's time; please email us at ride@rockymounts.com or call us at 800.873.1871. For the most efficient service, email a digital photo (we need this photo to verify the problem) of the product in questions, a brief description of the situation, and your purchase receipt. Our techs will respond within one business day. Most of the time we'll replace the part in question, but we may ask for more details.

RockyMounts, Inc. warranty only covers RockyMounts, Inc. products. It does not cover theft, or damage to vehicles and/or equipment. All products purchased prior to Jan 1, 2014 are covered by a one-year warranty; see your product manual for details.