

NOTES: UNLESS OTHERWISE SPECIFIED

1. SEE DRAWING NO. CB-00288 AND PROCEDURE P-1000 FOR ASSEMBLY AND TEST INSTRUCTION. PROCEDURES AND ASSEMBLY DRAWING ARE FOR INTERNAL USE ONLY.
2. ALL TESTING IS PERFORMED IAW BATTERY COUNCIL INTERNATIONAL STANDARDS.
3. ALL DIMENSIONS ARE IN INCHES [MM]
4. TERMINAL HARDWARE KIT PROVIDED, PART NUMBER 6923

REVISIONS			
REV	DESCRIPTION	DATE	APPROVED
A	CHANGED HANDLE DIRECTION	2/26/07	JBT
B	REV COVER, HANDLE, AND NOM WT, WAS 82 lbs, ADDED NOTE 4	11/6/07	JBT
C	REVISED TERMINAL DAMS, TERMINAL HEIGHT & HANDLES	9/16/09	JBT

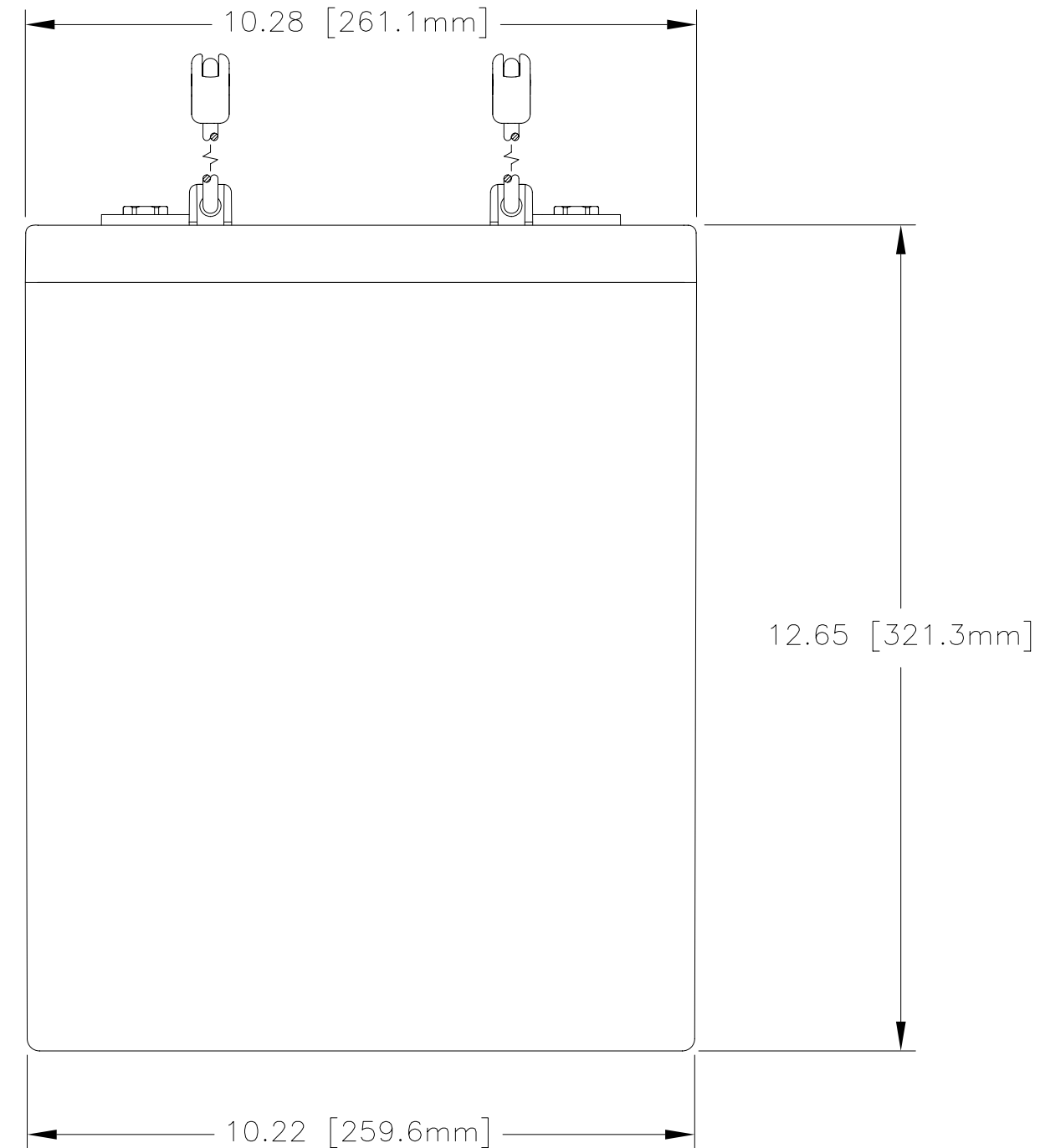
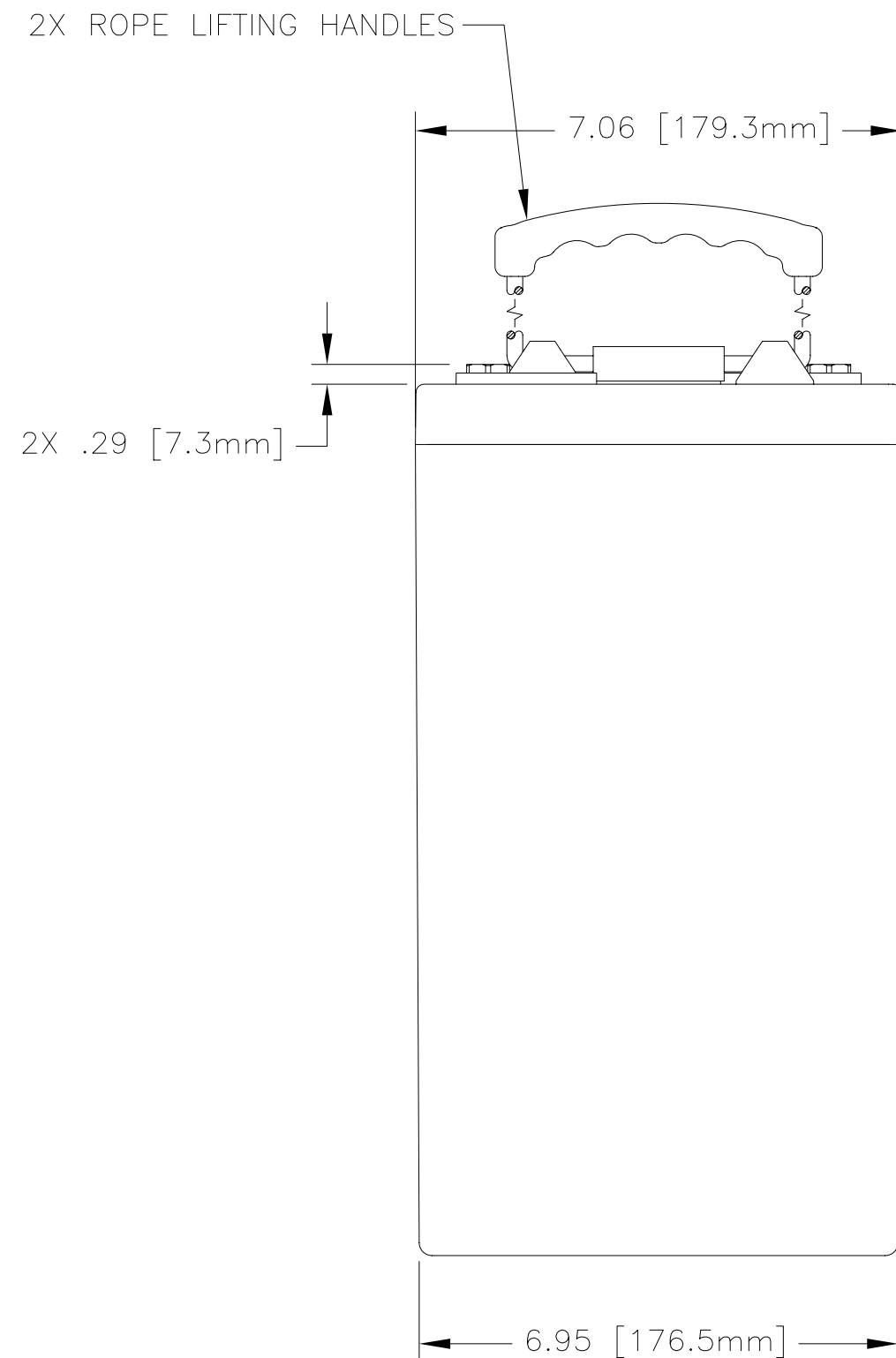
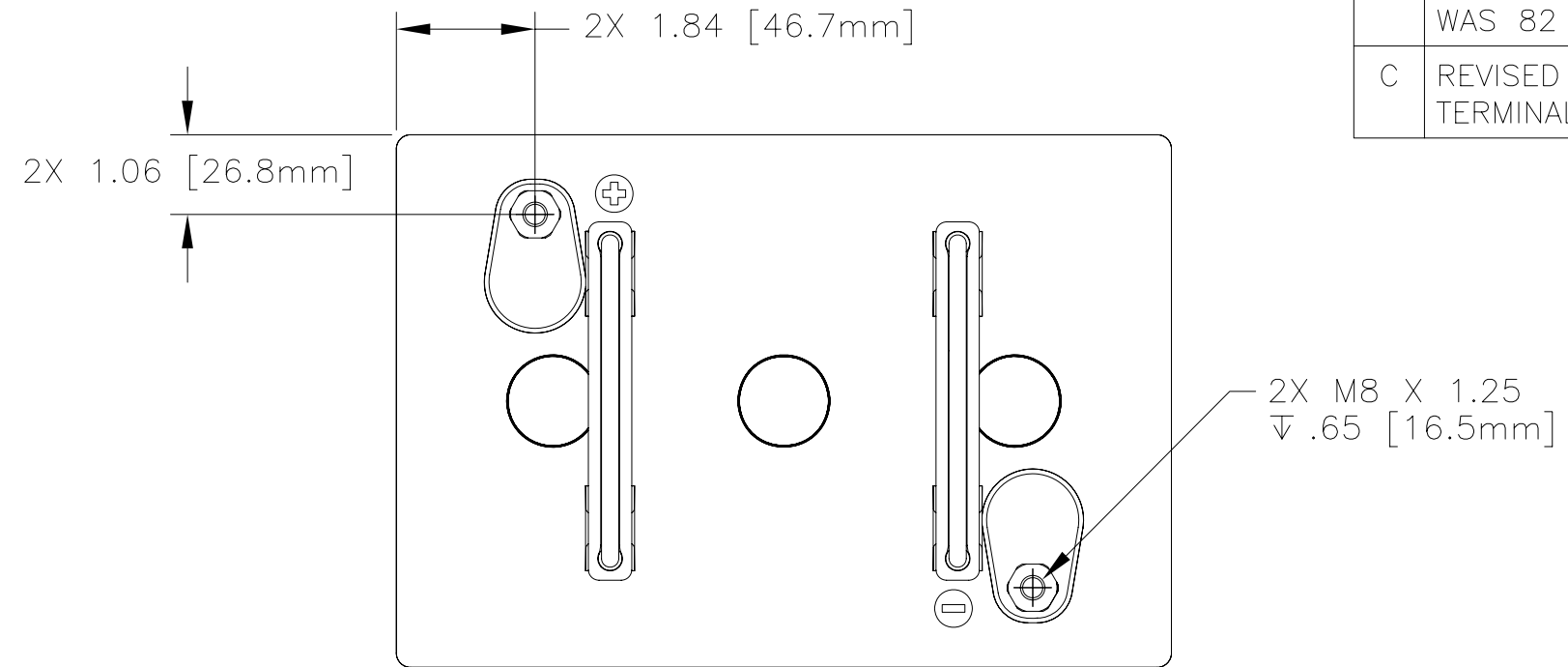

ENVELOPE DRAWING

CAPACITY RATINGS	
PART NUMBER	GPL-6CT
NOMINAL WEIGHT	90 LBS [40.8 KG]
AMPERE HOUR CAPACITY @ 20 HOUR 1.75 VOLTS/CELL @ 77°F (25° C)	300 AH
MINUTES OF DISCHARGE @ 25 AMPS 1.75 VOLTS/CELL @ 77°F (25° C)	692 MIN

QTY REQD	CAGE CODE	PART OR IDENTIFYING NO.	NOMENCLATURE OR DESCRIPTION	MATERIAL SPECIFICATION	ITEM NO.
PARTS LIST					
UNLESS OTHERWISE SPECIFIED DIMENSIONS ARE IN INCHES TOLERANCES ARE: FRACTIONS DECIMALS ANGLES ± 1/32 .XX ± .12 ± ± 1' .XXX ± .060			CONTRACT NO.	CONCORDE BATTERY CORPORATION 2009 SAN BERNARDINO RD, W. COVINA, CA 91790	
TREATMENT NONE			APPROVALS	TITLE BATTERY, 6 VOLT, GPL-6CT	
FINISH NONE			DRAWN RM	DATE	SIZE
SIMILAR TO N/A			CHECKED AMIII	12/1/06	CAGE CODE 63017
ACT WT N/A			APPROVED JBT	12/7/06	DWG NO. GPL-6CT
CALC WT N/A			ISSUED JJ	9/18/09	REV C
SCALE 1=2.5				SHEET 1 OF 1	