

NOTES: UNLESS OTHERWISE SPECIFIED

1. SEE DRAWING NO. CB-00294 AND PROCEDURE P-1000 FOR ASSEMBLY AND TEST INSTRUCTION. PROCEDURES AND ASSEMBLY DRAWINGS ARE FOR INTERNAL USE ONLY.
2. ALL TESTING IS PERFORMED IAW BATTERY COUNCIL INTERNATIONAL STANDARDS.
3. DIMENSIONS ARE INCH [MILLIMETER].
4. TERMINAL HARDWARE KIT PROVIDED, PART NUMBER 6916.

REVISIONS			
REV	DESCRIPTION	DATE	APPROVED

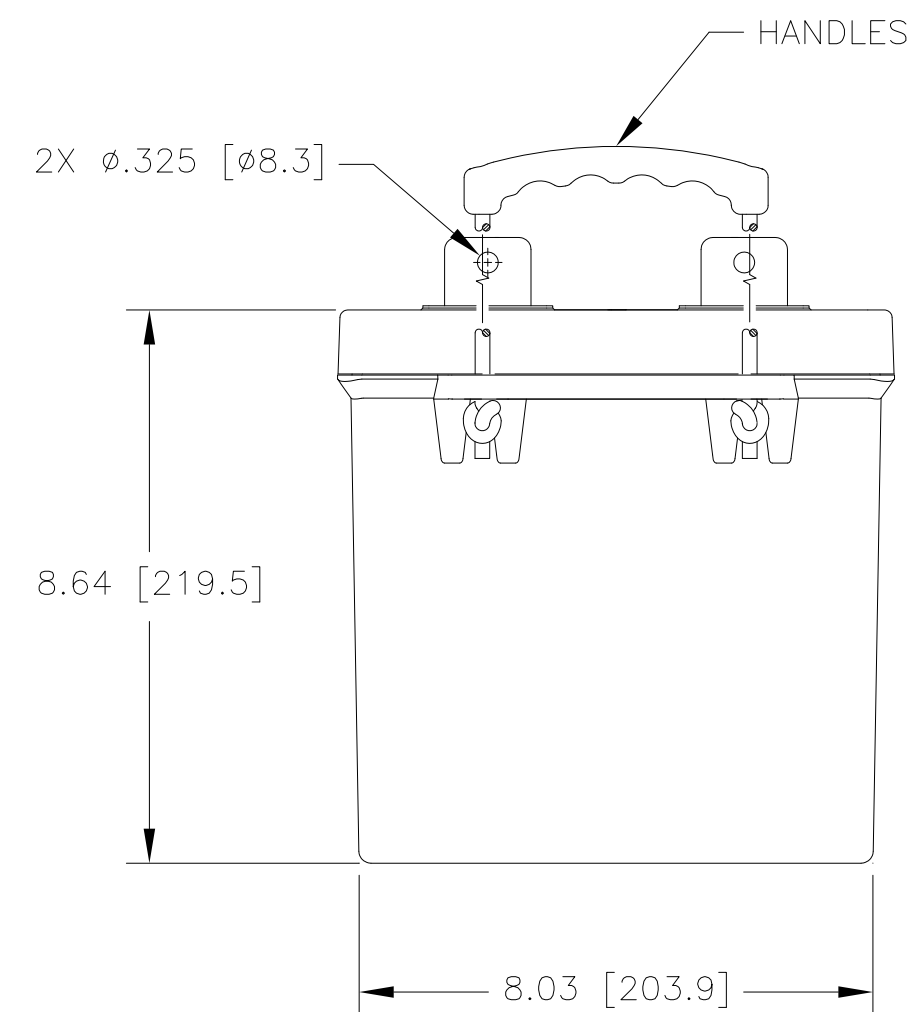
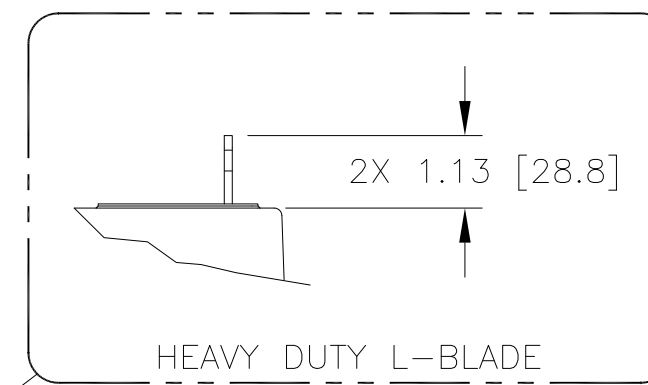
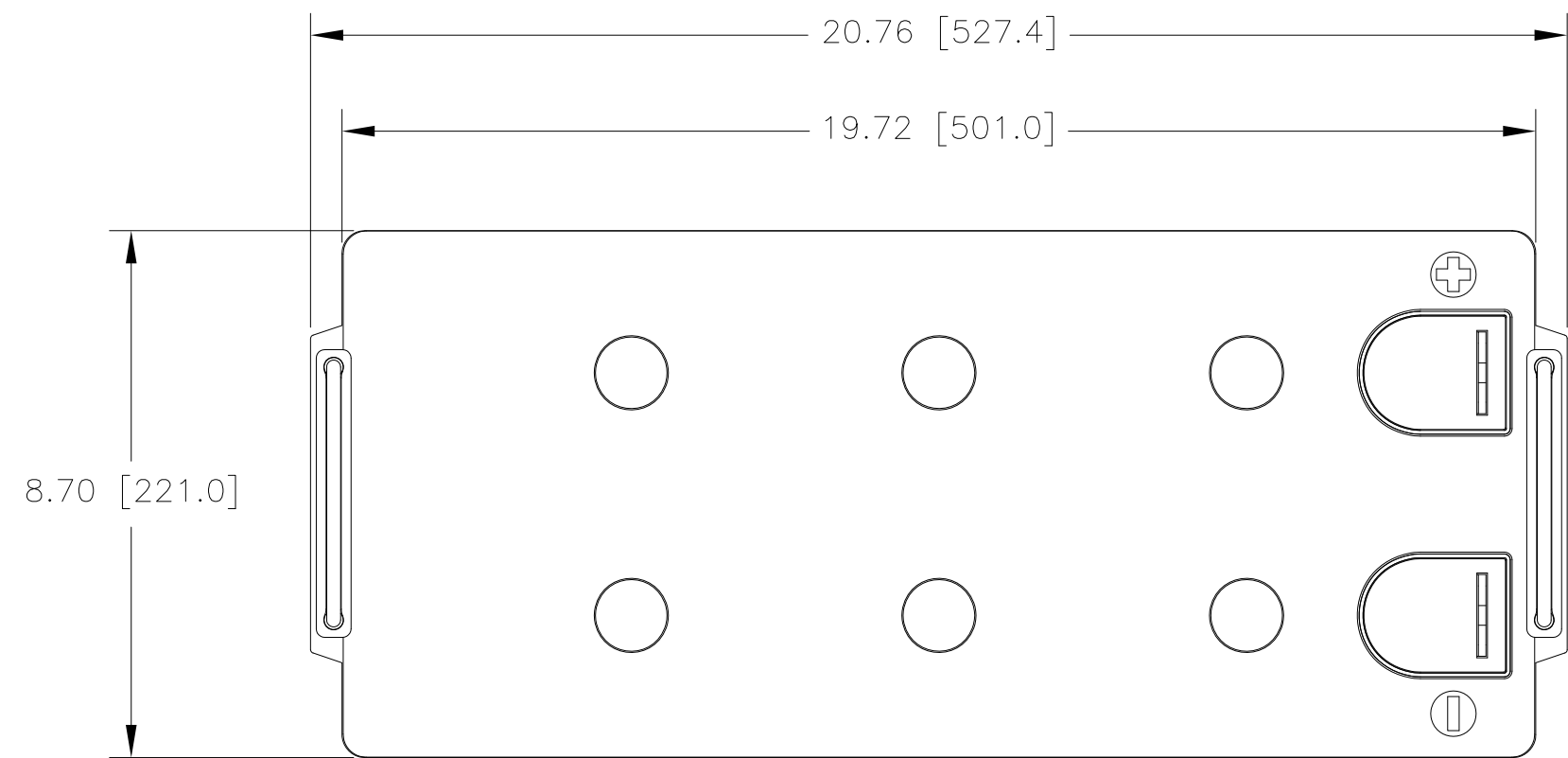

ENVELOPE DRAWING

CAPACITY RATINGS	
PART NUMBER	AGM-12210L
NOMINAL WEIGHT	124 LBS[56.2 KG]
AMPERE HOUR CAPACITY @ 20 HOUR 1.75 VOLTS/CELL @ 77°F (25° C)	210 AH
MINUTES OF DISCHARGE @ 25 AMPS 1.75 VOLTS/CELL @ 77°F (25° C)	390 MIN

QTY REQD	CAGE CODE	PART OR IDENTIFYING NO.	NOMENCLATURE OR DESCRIPTION	MATERIAL SPECIFICATION	ITEM NO.
PARTS LIST					
UNLESS OTHERWISE SPECIFIED DIMENSIONS ARE IN INCHES TOLERANCES ARE:			CONCORDE BATTERY CORPORATION 2009 SAN BERNARDINO RD, W. COVINA, CA 91790		
FRACTIONS	DECIMALS	ANGLES	APPROVALS	DATE	TITLE
± 1/32	.XX ± .12	± 1'	N. SANCHEZ	7/22/20	BATTERY, 12 VOLT, AGM-12210L
	.XXX ± .060		CHECKED	AMIII	7/23/20
TREATMENT	NONE		APPROVED	PH	7/23/20
FINISH	NONE		ISSUED	DH	7/27/20
SIMILAR TO	ACT WT	CALC WT			
			SCALE	NONE	SHEET 1 OF 1