

BENCH/ FLOOR SCALE

- AUTO CALIBRATION
- AUTO ZERO TRACKING
- PRE-TARE FUNCTION
- FULL TARE FUNCTION BY SUBTRACTION

- HOLD FUNCTION
- SIMPLE COUNTING FUNCTION 10 , 20, 50, 100, 200
- CHECKWEIGHER - HI/LO/OK AUDIO / VISUAL
- WEIGHT ACCUMULATION TO 9999 (MAX 6 DIGITS)

- ADJUSTABLE INDICATOR - TOWER OR TABLE
- RECHARGEABLE BATTERY 200 HOUR & AC POWER ADAPTER
- WELDED STEEL BASE CONSTRUCTION
- STAINLESS STEEL PLATFORM COVER
- OVERLOAD WARNING & PROTECTION
- LEVELING FEET & **OPTIONAL WHEELS**
- **SELECTABLE RESOLUTION**

PLATFORM SIZE
16 1/4 " x 20 1/2"

TOWER HEIGHT
26"

OPERATING TEMPERATURE
0° - 40°C (32° - 104°F)

SHIPPING WEIGHT
45 lb

SD931 SERIES

75 kg X 0.005 kg 150 lb X 0.01 lb or 150 lb X 0.1 oz

150 kg X 0.01 kg 330 lb X 0.02 lb or 330 lb X 0.2 oz

300 kg X 0.02 kg 660 lb X 0.05 lb or 660 lb X 0.2 oz



SPECIFICATIONS ARE SUBJECT TO CHANGE WITHOUT NOTICE

CCI
SCALE COMPANY

SD931 SERIES

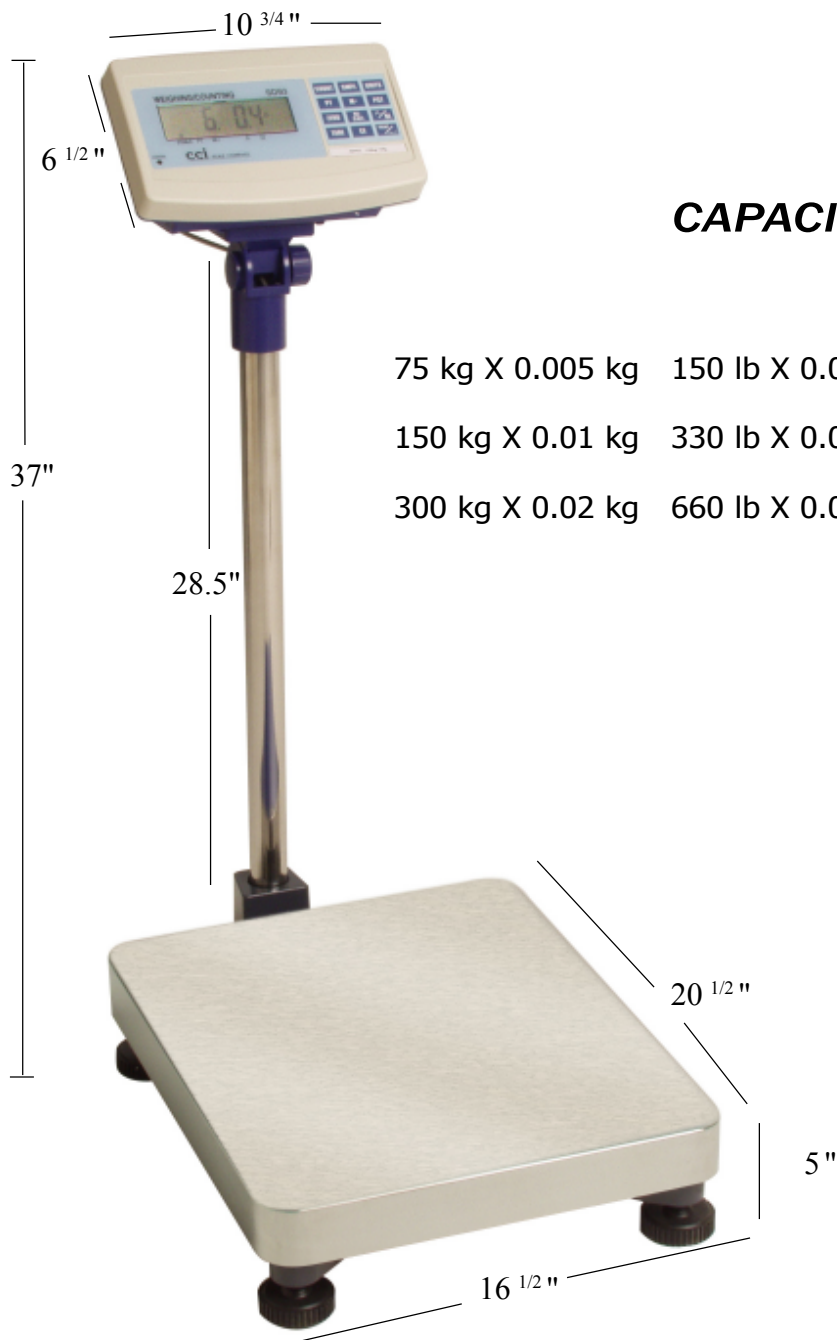

CAPACITIES

75 kg X 0.005 kg	150 lb X 0.01 lb or 150 lb X 0.1 oz
150 kg X 0.01 kg	330 lb X 0.02 lb or 330 lb X 0.2 oz
300 kg X 0.02 kg	660 lb X 0.05 lb or 660 lb X 0.2 oz



SPECIFICATIONS ARE SUBJECT TO CHANGE WITHOUT NOTICE