Weighing Scale

USER INSTRUCTIONS

TABLE OF CONTENTS

BEFORE USING THE SCALE.....	2
PREPARING TO USE THE SCALE.....	2
LCD DISPLAY.....	3
KEYBOARD FUNCTION.....	4
OPERATION.....	5
1. DISPLAY BACKLIGHT	5
2. ZERO	5
3. WEIGHING MODE.....	5
(1). Units Selection	5
(2). Totalising	5
I. Weight Totalising	6
II. Clear Totalised Weight Values	6
III. Recall Totalised Weight Value	6
(3). Deduction of the Container Weight.....	7
I. The weight of the container is unknown (Tare).....	7
II. Clear the semi-auto tare.....	7
III. Recall the semi-auto tare value.....	7
IV. The weight of the container is known (Pre-set tare).....	8
V. Clear the pre-set tare value	8
VI. Recall the pre-set tare value.....	8
(4). Check Weighing.....	9
I. Pre-set the “Low limit value”, “High limit value”, and “the buzzer” operation	9
II. Pre-set the Low limit value only.....	10
III. High/OK/Low indication.....	10
IV. Recall the check weighing setting.....	10
V. Clear the check weighing settings.....	10
4. COUNTING FUNCTION	11
(1). Sampling	11
(2). Totalising	11
(3). Check Weighing.....	11
CONFIGURATION SETTINGS.....	12
1. CHECK-WEIGHING CONFIGURATION F4	13
2. RS-232 SETTING F5	14
3. EXIT CONFIGURATION SETTINGS F6	15
4. HOLD SETTING F8	16
RS-232 SERIAL OUTPUT.....	18
RS-232 SERIAL PRINTER OUTPUT (OPTIONAL INTERFACE)	18
(1) RS-232 (25 Pin ‘D’ type) Pin Description.....	18
(2) RS-232 Interface Format.....	18
(3) Data Format	19

BEFORE USING THE SCALE

To enable you to use this scale correctly, we suggest that you read this manual carefully.

1. Do not use scale in areas with excessive water and don't spray the scale with water when cleaning. Remove all water from the scale with a clean dry cloth.
2. The load placed on the platform must not exceed the maximum weighing capacity of the scale.
3. Keep the scale away from high temperatures and damp conditions.
4. If the scale is not going to be used for some time, please clean it and store it in a plastic bag in dry conditions. A desiccant sachet may be included to prevent moisture build up.
5. If the scale is not going to be used for some time, the internal rechargeable battery should be recharged every three months.
6. Before using the scale after a long period of storage, please ensure that the internal battery is fully charged. NOTE: Care should be taken not to leave the internal battery on charge for too long, as this may decrease the life of battery.

PREPARING TO USE THE SCALE

1. Locate the scale on a firm level surface free from vibrations for accurate weight readings.
2. Adjust the four levelling feet to set the scale platform level using the spirit level bubble located on the scale platform frame.
3. Avoid operating the scale in direct sunlight or drafts of any kind.
4. Remove any weight that might be on the scale platform before the scale is switched on.
5. Once the scale has been switched on, it will go through a LCD display test and then re-zero to be ready for use.
6. The scale requires 15~20 minutes warm up before operation to ensure best accuracy.
7. Please note when the  symbol is shown on the display, the internal battery needs to be recharged.
8. All goods weighed should be placed in the centre of the platform for accurate weighing. The footprint of the goods being weighed should not overhang the edges of the platform.

LCD DISPLAY

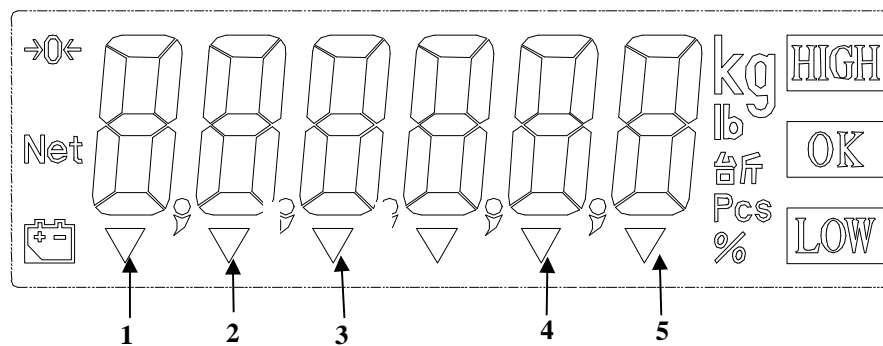

HIGH : High Preset Weight Limit

OK : The range between Low & High Limit Weight Limit

LOW : Low Preset Weight Limit

kg : “kg” unit

lb : “lb” unit

Pcs : “COUNTING” mode indicating the number of pieces

0 : “ZERO” indication and platform stable confirmation

Net : “Net Weight ”indication

 : “Low Battery” indication

61 : (STABLE) “Stable” indication







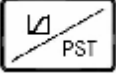
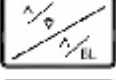

62 : (PT) “Pre-set Tare” mode

63 : (M+) “Accumulation” mode

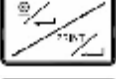
64 : () “Sample Too Small” indication

65 : () “Piece Weight Too Small” indication

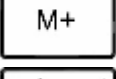
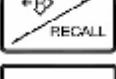
KEYBOARD FUNCTION

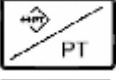
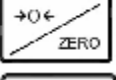
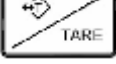
1.  : Units Key to choose the unit weight kg or lb.
2.  : Preset High & Low Limit.
3.  :  ⇒ Data Entry Key,  ⇒ Backlight Key.
4.  :  ⇒ Print Key to print the total data ;  ⇒ Confirmation Key.
5.  : Sample Key to set the unit weight of sample.
6.  : Accumulation Key to add the displayed value into memory.
7.  : Re-call accumulated value or preset high & low limit value or preset tare value.
8.  : Clear Key to delete the existing accumulated values, preset high & low limit value or preset tare value.
9.  : Press this key to enter counting mode.
10.  : Preset Tare Key.
11.  : Zero Key to re-zero the weight.
12.  : Tare Key to deduct the container weight.

OPERATION

1. DISPLAY BACKLIGHT

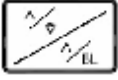
Press  key to choose the display backlight mode :

bl. AUTO ⇒ “Auto Backlight” mode. When the weight is over 10 divisions or any key is pressed, the display backlight will be switched on. When the weight returns to zero (the weight on platform is less than 10 divisions), the display backlight will switch off after 5 seconds.

bl. ON ⇒ Display backlight is on all the time.

bl. OFF ⇒ Display backlight is off.

2. ZERO

When the weigh pan is empty (free of load) and the display is not showing zero, press the

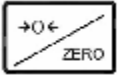
 key to zero the scale. At zero, the “**à 0β**” indication is on.

3. WEIGHING MODE

(1). Units Selection

- I. Press  key to choose the weighing units and the display will show the “kg” or “lb” symbol on the top right of the LCD display.
- II. The unit status will be memorized when you turn the machine off.

(2). Totalising

- ◆ The totalising function can be used up to a maximum of 9999 times before it must be reset. The totalising display is limited to 6 digits maximum.
- ◆ The scale allows the next totalising operation, even when the weight value does not return back to

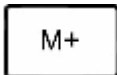
zero. The  key is functional, when the weight value changes by more than 10 d. The scale will store the totalised weight value after the weight is stable.

I. Weight Totalising

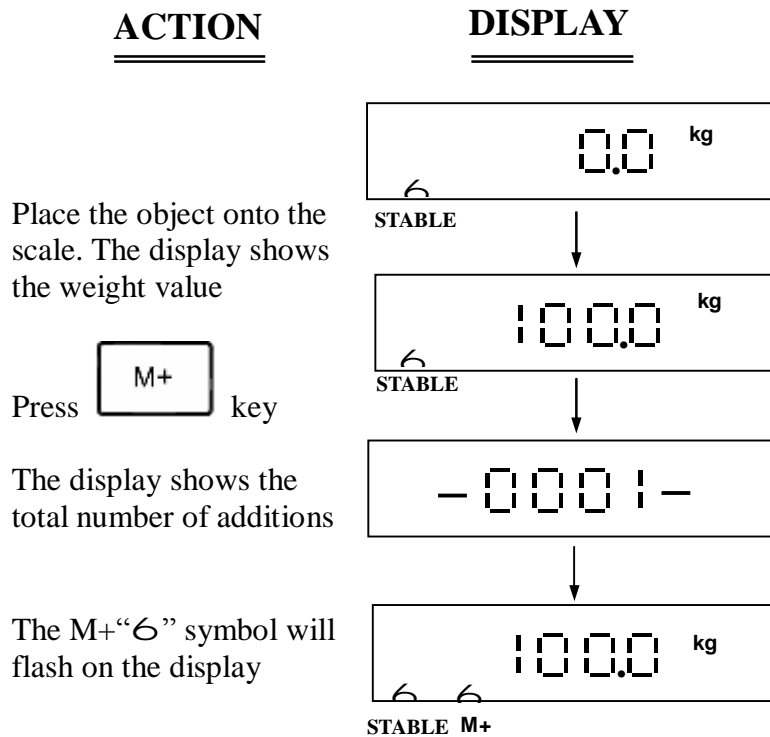

- ✓ The scale can totalise positive or negative weight but not both at the same time. The totalised weight must be cleared before it is possible to change positive or negative totalising mode.

II. Clear Totalised Weight Values

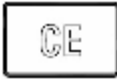

- ◆ Press  key followed by pressing  key to clear the totalised weight values.
- ◆ All totals will be lost when the mode is changed from weighing to counting or vice versa and when the scale is switched off.

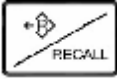
III. Recall Totalised Weight Value

- ◆ Press  key to display the totalised weight value and the total number of additions. The M+“6” symbol will flash on the display. The scale will return to the weighing mode after 3 seconds.
- ✓ The scale will not display the negative sign “-” for negative totalised weight values, but the negative sign “-“ will be printed out (transmitted serially) for each negative weight and negative totalised weight.

(3). Deduction of the Container Weight

I. The weight of the container is unknown (Tare)

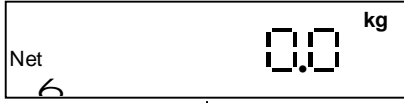
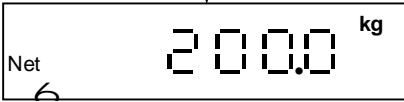
<u>ACTION</u>	<u>DISPLAY</u>
Place the container onto the scale	
Press  key when the weight is stable. The weight value becomes zero and the (Net) symbol is displayed	
Place the object into the container and the display shows the net weight value of the object	

II. Clear the semi-auto tare

When the container is removed from the scale, the display shows the container weight value with

a negative sign. Press  key to reset the scale to zero, and the (Net) symbol will switch off.

- ✓ Multiple tare operation ⇒ Users can continuously increase or decrease the tare value by pressing the



 key.

- ✓ The total tare value (tare value + pre-set tare value) can equal the full capacity of the scale.

III. Recall the semi-auto tare value

Press  key followed by pressing  key ⇒ The display shows the tare weight value.

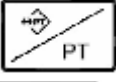
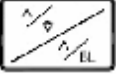
IV. The weight of the container is known (Pre-set tare)

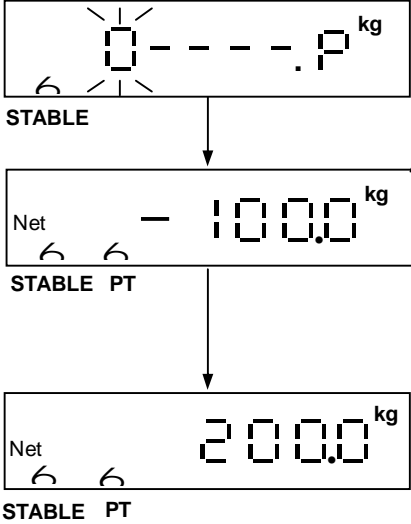
<u>ACTION</u>	<u>DISPLAY</u>	<u>DESCRIPTION</u>
<p>Press  key</p> <p>Use  key to enter the weight value of the container followed by</p> <p>pressing  key</p> <p>Place the object with the container onto the weigh pan.</p> <p>The display shows the net value of object</p>	 <p>The display shows the weight value of the container with the negative sign and the (Net) symbol flashes on the display. The PT symbol indicates the tare function is active.</p>	

V. Clear the pre-set tare value

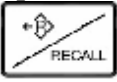
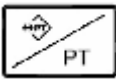
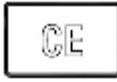

Press  key followed by pressing , then press  key to clear the pre-set tare value. The scale resets back to zero, and the (Net) symbol and the PT symbol will switch off.

VI. Recall the pre-set tare value



Press  key followed by pressing  ⇒ The display shows the pre-set tare value.

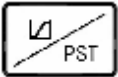







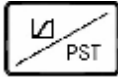
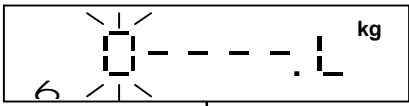

✓ NOTE: In Tare mode, the Pre-set tare function is not available.

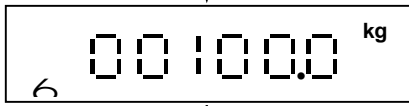
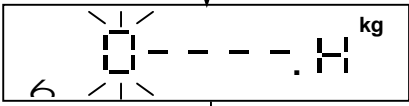
(4). Check Weighing

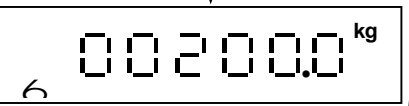
Press  to enter the check weighing function. Press  key to abandon the setting and return back to the weighing mode.

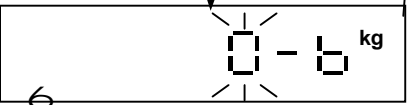
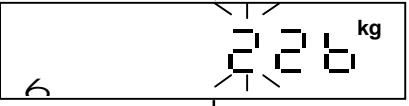
I. Pre-set the “Low limit value”, “High limit value”, and “the buzzer” operation

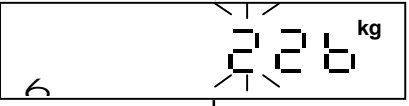
Press  key to enter the value required and step to the next digit by pressing the  key.

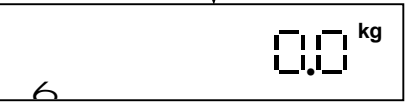
<u>ACTION</u>	<u>DISPLAY</u>	<u>DESCRIPTION</u>
Press  key to select the check weighing function		
Press  key to enter the Low limit value. Press  key to confirm the setting		
Set the “High limit value”		
Press  key to enter the High limit value.		
Press  key to confirm the setting		
Set the “buzzer” operation		
Press  key to enter the buzzer operation.		
Press  key to confirm the setting		
The scale returns to the weighing mode		

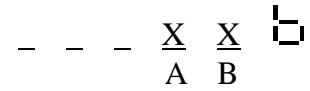

A ⇒ 0 = When the weight is stable the buzzer sounds and the High, OK or Low icon is displayed.

1 = The High, OK or Low icon is displayed irrespective of the stability of the weight. The buzzer sounds only when the weight is stable.

2 = The buzzer sounds and the High, OK or Low icon is displayed irrespective of the stability of the weight.

B ⇒ 0 = The buzzer does not sound.

1 = The buzzer sounds at the OK status.

2 = The buzzer sounds when the weight of the object is lower or equal to the Low limit value, or higher than the High limit value.

II. Pre-set the Low limit value only

After completing the Low limit value setting, the display shows

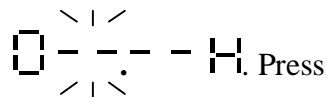

Press

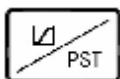

key to complete the setting, and the display shows

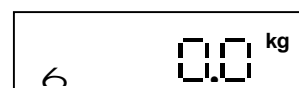

STABLE

- When users only pre-set the Low limit value, the buzzer setting is fixed at: **6 2 1**

III. High/OK/Low indication

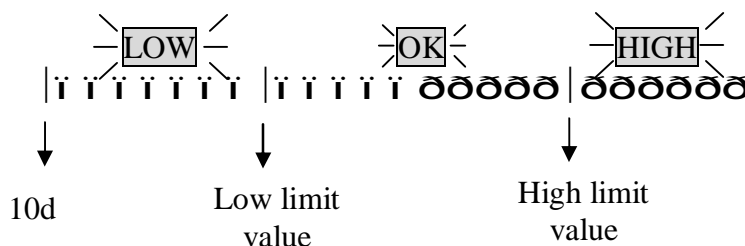

IV. Recall the check weighing setting

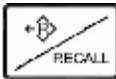

Press  key followed by pressing  key to recall the Low limit value.

Then press  key again to recall the High limit value.

Then press  key again to recall the buzzer setting.

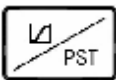
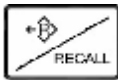

Then press  key again to return the weighing mode.

V. Clear the check weighing settings

Press  key followed by pressing  key, then press  key to clear the Low limit value.

Press  key again to clear the High limit value and the buzzer setting.

4. COUNTING FUNCTION

Press  key to enter the counting function. Press  key to return back to the weighing mode.

(1). Sampling

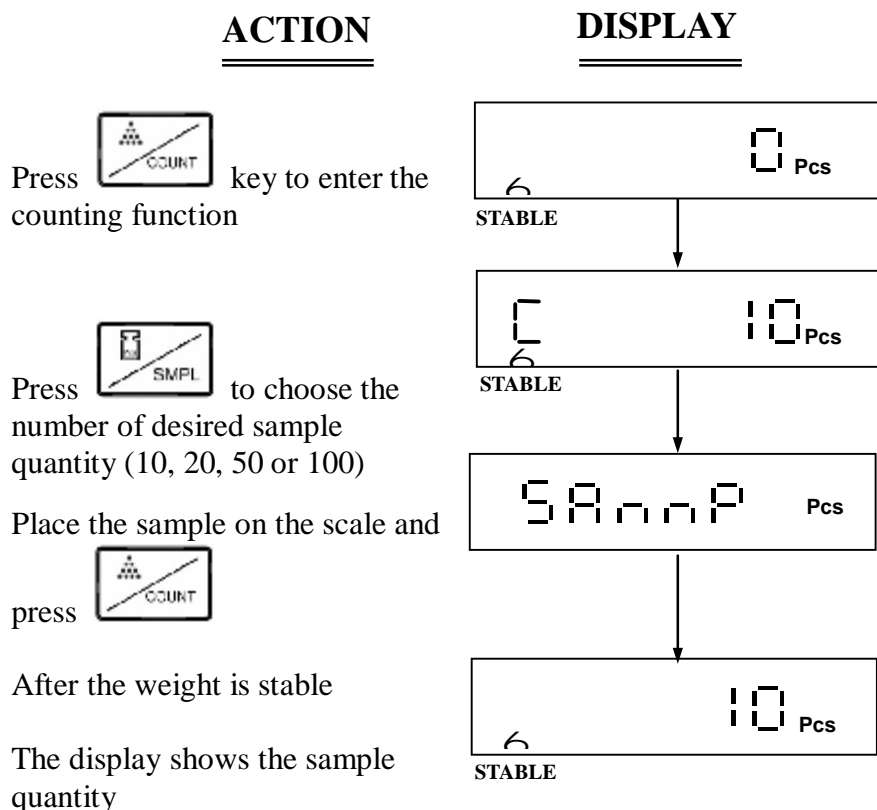

NOTE:

- ◆ The larger the sample size, the more accurate the unit weight. (The minimum sample weight = 20d)
- ◆ A sample size of 10 pieces gives a typical count accuracy of 95%.
- ◆ A sample size of 50 pieces gives a typical count accuracy of 98%.

SAMPLE TOO SMALL () ⇒ Sample is less than 20 divisions.

UNIT WEIGHT TOO SMALL () ⇒ Unit weight is less than 1/5 of a division.

Under such conditions, the scale can still work, but may result in lower count accuracy.

(2). Totalising

Refer to the operation of totalising in the weighing function on page 7.

(3). Check Weighing

Refer to the operation of check weighing function on page 11.

CONFIGURATION SETTINGS

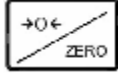
Switch on the scale. While the scale is counting backward to zero, press and hold  key until the display shows the software program version number: “02001”.

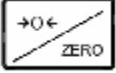

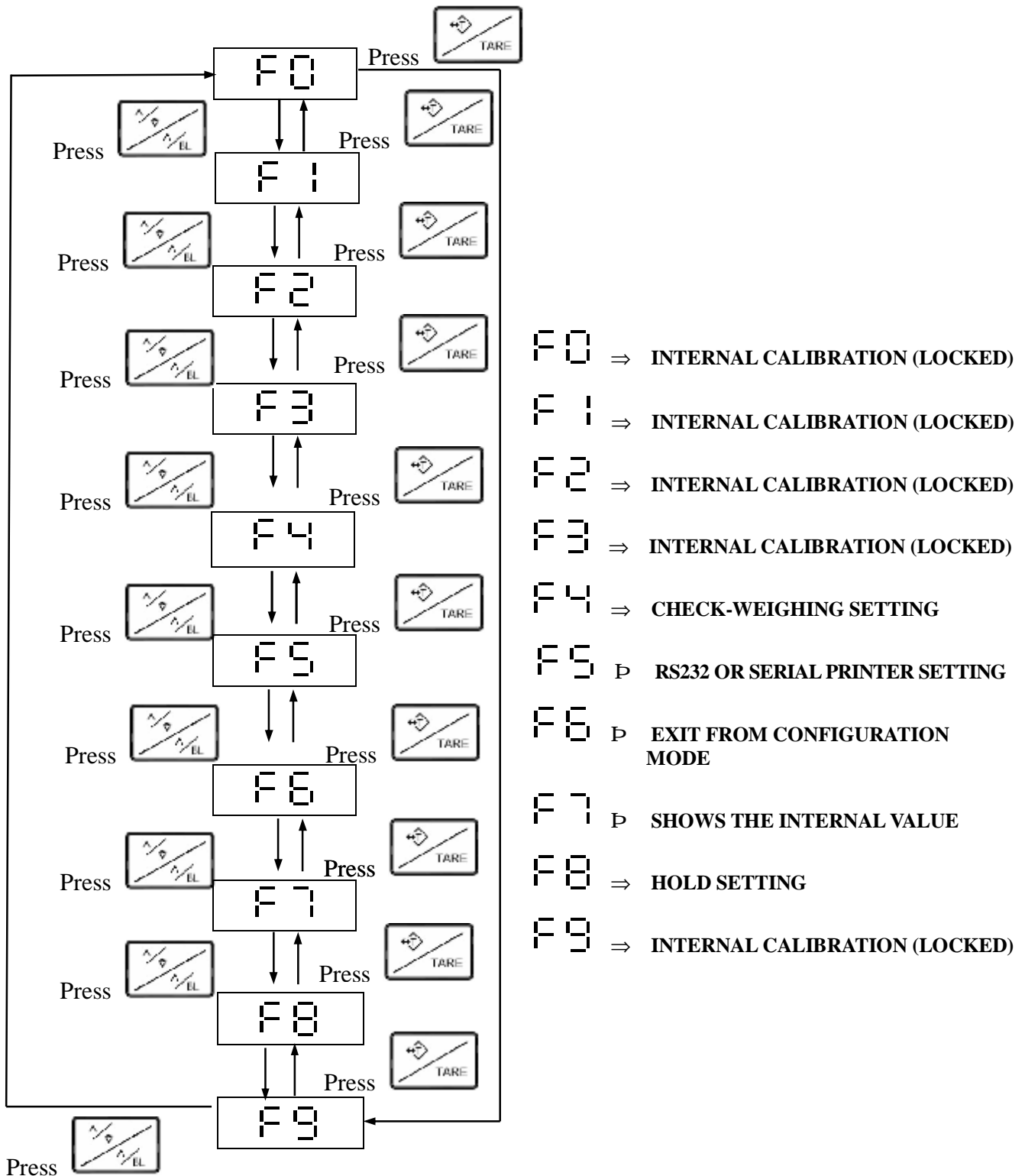

Release  key, the scale enters the configuration setting mode. F0 is displayed.

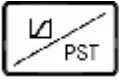
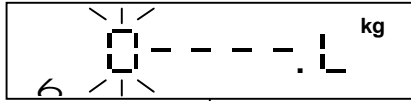
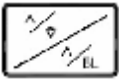
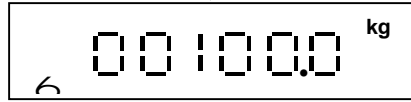
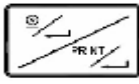
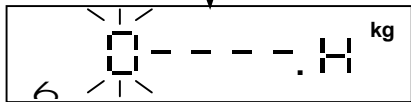

1. CHECK-WEIGHING CONFIGURATION F4

◆ F8 (Hold) affects access to F4. If F8 is set, access to F4 is denied.

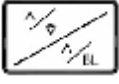
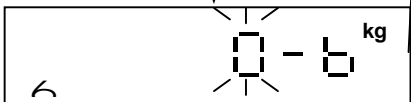
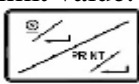
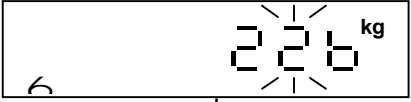
Press  or  key to select **F4** function ⇒ the display shows **F4**

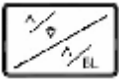
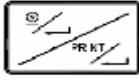
<u>ACTION</u>	<u>DISPLAY</u>	<u>DESCRIPTION</u>
Press  key to select the check weighing function		
Press  key to enter the Low limit value.		
Press  key to confirm the setting		
Set the "High limit value"		
Press  key to enter the High limit value.		
Press  key to confirm the setting		
Set the "buzzer" operation		
Press  key to enter the buzzer operation.		
Press  key to confirm the setting		
The scale returns to the weighing mode		

$$\begin{matrix} \text{---} & \text{X} & \text{X} & \text{b} \\ & \text{A} & \text{B} & \end{matrix}$$

A ⇒ 0 = When the weight is stable the buzzer sounds and the High, OK or Low icon is displayed.

1 = The High, OK or Low icon is displayed irrespective of the stability of the weight. The buzzer sounds only when the weight is stable.

2 = The buzzer sounds and the High, OK or Low icon is displayed irrespective of the stability of the weight.



B ⇒ 0 = The buzzer does not sound.







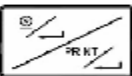
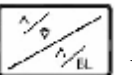

1 = The buzzer sounds at the OK status.

2 = The buzzer sounds when the weight of the object is lower or equal to the lower limit value, or higher than the upper limit value.

2. RS-232 SETTING F5

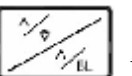

- ◆ J1 and J3 on the RS-232 interface are connected together (short), when the RS-232 interface is connected to a computer.
- ◆ J2 and J4 on the RS-232 interface are connected together (short), when the RS-232 interface is connected to a printer.

Press  or  key to select the **F5** function ⇒ the display shows **F5**

<u>ACTION</u>	<u>DISPLAY</u>	<u>DESCRIPTION</u>
Press  key	F5	r n P 0 P No transmission
Transmission default mode	r n P 0	r n P 1 P Stable transmission
Press  key to set the transmission mode	r n P 4	r n P 2 P Continuous transmission
Then press  key to confirm the setting	2400	r n P 3 P Press  to transmit (simple mode)
Baud rate default setting	9600	r n P 4 P Press  to transmit (complete mode)
Press  key to set the baud rate (1200, 2400, 4800 or 9600)	F5	r n P 5 P Stable transmission (totalising mode). The format is as same as r n P 3 .
Then press  key to confirm the setting		r n P 6 P EZ-2 printer mode The format is as same as r n P 4 .
Configuration complete		r n P 7 P Press  to transmit (EZ-2 printer mode)
		r n P 8 P Press  to transmit The format is the same as r n P 1 & 2

- ✓ When choosing “EZ-2 printer mode“, the Baud rate should be set to 9600 bps
- ✓ Refer to Page 19~22 for RS-232 data format

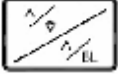
3. EXIT CONFIGURATION SETTINGS F6

Press  or  key to select the F6 function⇒ the display shows F6

ACTION

DISPLAY

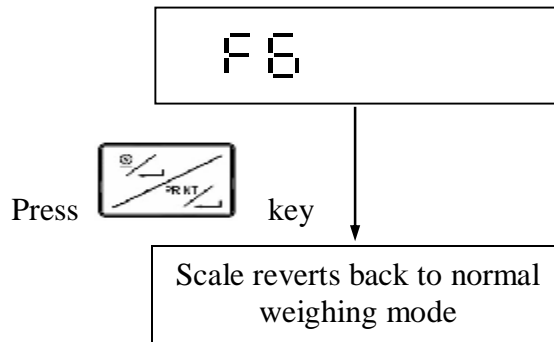

4. HOLD SETTING F8

- When the hold function is active, the display will show the maximum weight on the weigh pan.

Press the  key to print out the weight value.

Press  or  key to select F8 function ⇒ the display shows **F8**

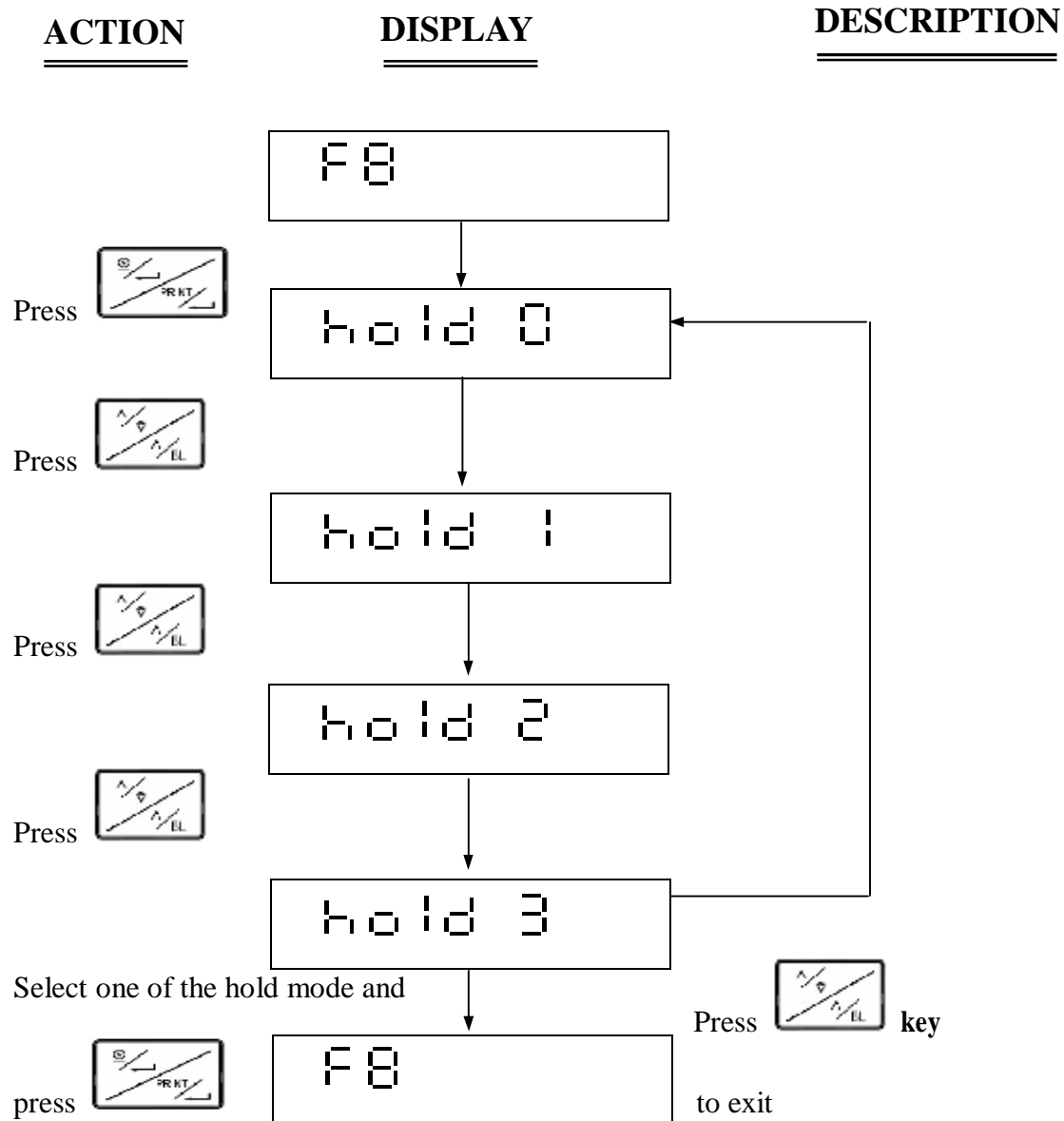

hold 0 = No hold function.

hold 1 = With a changing weight value, the scale automatically hold the maximum value displayed.

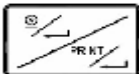
Pressing any key except the  key to cancel the hold function.

hold 2 = When the weight is stable, the scale hold the displayed value.

Pressing any key except the  key to cancel the hold function.

hold 3 = When the weight is stable, the scale will hold the displayed value. When the scale returns to zero (the weight is less than 10 divisions), the hold function will be released.

RS-232 SERIAL OUTPUT

RS-232 SERIAL PRINTER OUTPUT (OPTIONAL INTERFACE)

(1) RS-232 (25 Pin 'D' type) Pin Description

· J1 - J3 SHORT ; J2 - J4 OPEN (default setting)

Pin 2 ⇒ RXD

Pin 3 ⇒ TXD

Pin 7 ⇒ GND

· J2 - J4 SHORT ; J1 - J3 OPEN

Pin 2 ⇒ TXD

Pin 3 ⇒ RXD

Pin 7 ⇒ GND

(2) RS-232 Interface Format

I . Mode : EIA-RS232 C's UART signal

II . Format :

1. Baud rate: 1200, 2400, 4800 or 9600 bps
2. Data bits: 8 BITS
3. Parity bit: none
4. Stop bits: 1 BIT
5. Code: ASCII

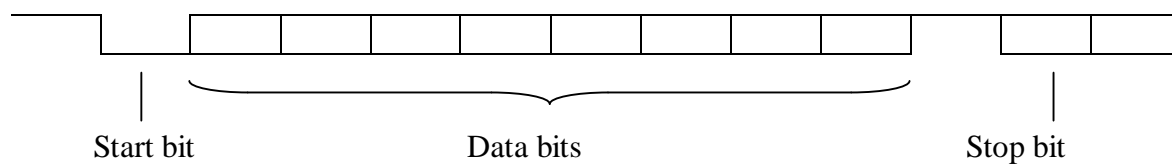

(3) Data Format

Stable transmission  / Continuous transmission 

Press  to transmit 

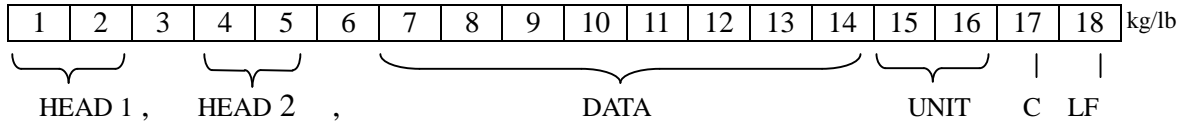

HEAD 1 (2 BYTES)	HEAD 2 (2 BYTES)
OL - Overload , Under load	TR - TARE Mode
ST - Display is Stable	NT - NET Mode
US - Display is Unstable	GS - GROSS Mode

DATA (8 or 9 BYTES)

2D (HEX) = “ - ” (MINUS)

2E (HEX) = “ . ” (DECIMAL POINT)

UNIT (2, 3 or 4 BYTES)

kg = 6B (HEX) ; 67 (HEX)

lb = 6C (HEX) ; 62 (HEX)

Transmission example:

1. With the weight stable, a tare set and a gross weight value of + 0.876 kg the data string is shown below:

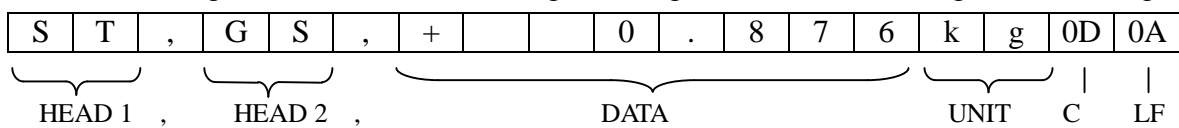



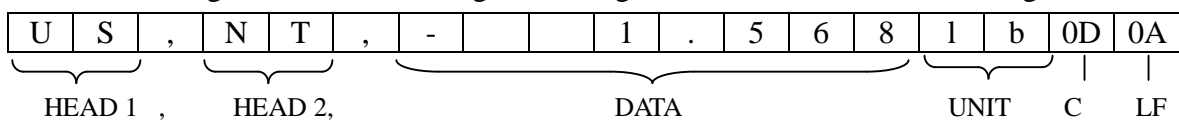



2. With the weight unstable, net weight the weight value -1.568lb the data string is shown below:

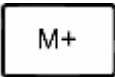

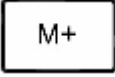
Press  key to transmit (simple mode)    

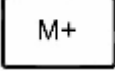
S/N WT/UNIT (kg / lb)

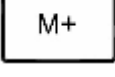
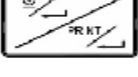
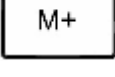
0001	1.0000	E Press  key or  key
0002	1.0000	E Press  key or  key
0003	1.0000	E Press  key or  key
0004	1.0000	E Press  key or  key
0005	1.0000	E Press  key or  key

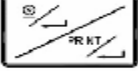



0005	5.0000	E Press  key 2 times to print out the total

Stable transmission (totalising mode)    

S/N WT/UNIT (kg / lb)









0001	1.0000	E scale stable, transmitting
0002	1.0000	E scale stable, transmitting
0003	1.0000	E scale stable, transmitting
0004	1.0000	E scale stable, transmitting
0005	1.0000	E scale stable, transmitting

0005	5.0000	E Press  key 2 times to print out the total

EZ-2 printer mode, press  to transmit     (Baud rate must be set at 9600 bps)

Only prints out the “weight value”. The proportion of the printed font ⇒ Height : Width = 3:2

+100.0 kg

EZ-2 printing mode    (Baud rate must be set at 9600bps). Press  key to transmit (complete mode)    

TICKET NO .0001
 G 1.000kg
 T 0.000kg
 PT 0.000kg
 N 1.000kg

(Blank line x 3)

TICKET NO .0002
 G 1.000kg
 T 0.000kg
 PT 0.000kg
 N 1.000kg

(Blank line x 3)

TICKET NO .0003
 G 1.000kg
 T 0.000kg
 PT 0.000kg
 N 1.000kg

(Blank line x 3)

TOTAL NUMBER
 OF TICKETS 0003
 TOTAL
 NET 3.000 kg

(Blank line x 3)

E Press  key or  key

E Press  key or  key

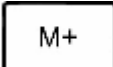
E Press  key or  key

E Press  key twice to printout the total

<Remarks> : G = GROSS T = TARE PT = PRE-TARE N = NET