

verilux[®]
The Healthy Lighting Company[®] Est. 1956

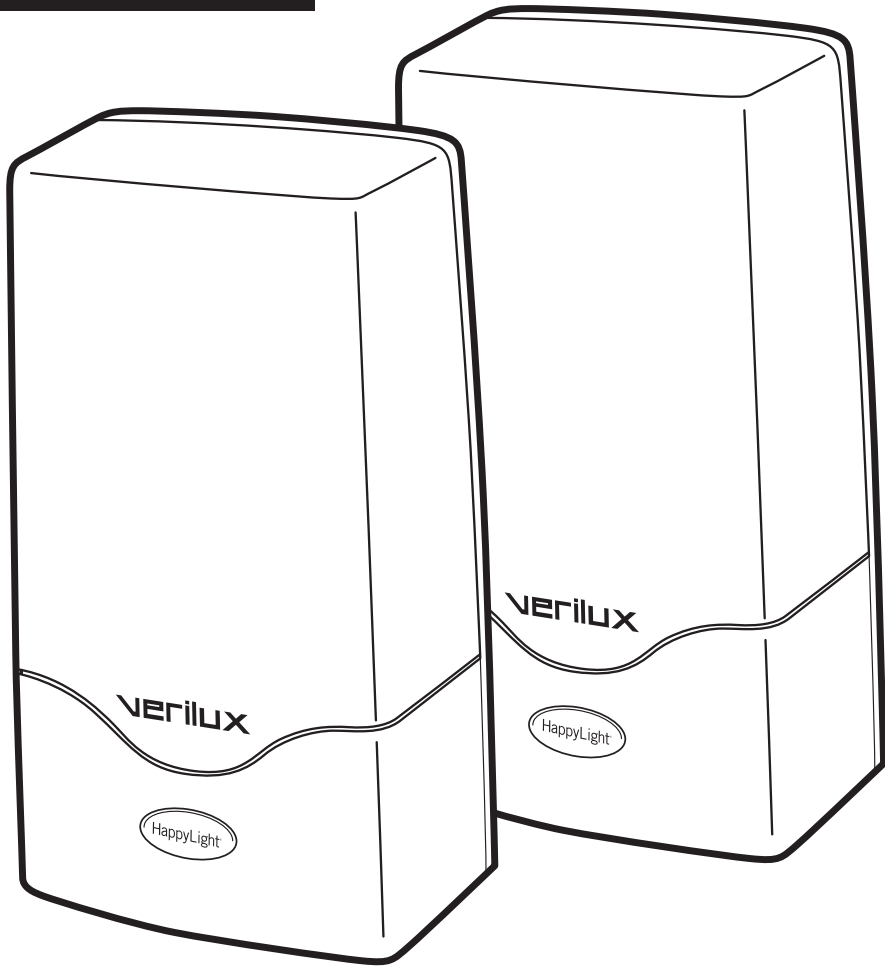

HappyLight[®] | twin pack

Compact Energy Lamp

VTCP01

Model: VT01-SB



Dear Customer,

Thank you for purchasing the Verilux® HappyLight® Compact Energy Lamp Twin Pack. You now own an innovative product, manufactured to the highest standards and backed by a one-year limited warranty.

This product brings Natural Spectrum® Daylight into your home or office. Many other healthy-lighting products are available through our catalog and online. Visit us on the web at www.verilux.com to request a free catalog and learn more about all of our quality Verilux products, or call our toll-free number: 1-800-454-4408.

As a Verilux customer, your satisfaction means everything to us. We look forward to serving you now and in the future.

Have a bright day!

A handwritten signature in black ink that reads "Nicholas Harmon". The signature is written in a cursive, flowing style.

Nicholas Harmon
President
Verilux, Inc.

Contents

Important Safeguards	4
Features.	5
Benefits	6
Device Pretest	6
Operation.	7
Selecting a Location	7
Instructions for Use	7
Recommended Use	8
Bulb Removal and Replacement.	8
Re-installing Bulb and Plastic Diffuser	9
Troubleshooting.	10
Care and Cleaning.	10
Technical Specifications	11
Warranty	12

READ ALL INSTRUCTIONS BEFORE USING

Important Safeguards

▲ DANGER:

- Do not operate this device near a water source to avoid electrocution.

▲ WARNING:

- Do not use with power supply voltage other than 120 VAC.
- Do not defeat the safety purpose of the polarized plug. A polarized plug has two blades with one wider than the other. The wider blade is provided for your safety. If the provided plug does not fit in your outlet, consult an electrician for replacement of the obsolete outlet.
- Close supervision is recommended when these lamps are used by or near children, or others who may not understand the need for these precautions.
- Do not operate lamp in close proximity to flammable or combustible vapors, such as aerosol spray products, or where oxygen is being administered.
- To prevent risk of shock or personal injury when cleaning lamp, make sure you have turned off and unplugged the lamp, and allowed sufficient time for the bulb to cool.
- If this lamp has been damaged in any way, for example, the power supply cord or plug has been damaged, liquid has been spilled or objects have fallen onto the lamp, the lamp has been exposed to rain or moisture, the lamp does not operate normally or has been dropped, it should not be operated. There are no user serviceable parts in this lamp.
- Do not block vents. Blocking them may cause overheating of the lamp and increase risk of fire.
- This bulb contains a trace amount of mercury, a chemical known to the state of California to cause birth defects or other reproductive harm.
- Some people may experience light sensitivity to fluorescent lighting. Discontinue use if you experience any discomfort. Follow directions for pretest on page 6 prior to use.
- Certain drugs may induce light sensitivity (e.g., anti-depressants) which may result in discomfort or a level of hyperactivity. Consult with your health care provider before using this product.
- If you have a pre-existing eye condition, consult with your health care provider before using this product.

▲ CAUTION:

- These lamps are for indoor use only.
- Avoid placing this lamp in areas that are exposed to direct sunlight or close to heat-radiating products such as heaters. Do not place the lamp on the top of appliances that radiate heat.
- Protect the power cord from being walked on or pinched, particularly at plugs, convenience receptacles and the point where the power cord exits the lamp.
- This lamp may cause interference with radios, cordless telephones or devices that use a wireless remote control, such as televisions. If interference occurs, move the lamp away from the device, plug the lamp or the device into a different outlet or move the lamp out of the line of sight of the remote control receiver.

▲ CAUTION: — continued

- Unplug lamp during lightning storms or when unused for long periods.
- Avoid placing the lamp in areas that are dusty, humid/moist, lack ventilation or are subject to constant vibration.
- This lamp is not for use with light dimmers, timers, motion detectors, voltage transformers or extension cords.
- Do not leave the lamp unattended during use.
- Do NOT use lubricating agent in assembly; please see troubleshooting section if you are having difficulty assembling your lamp.
- Light bulbs get hot quickly! Do not touch the bulb while the lamp is on.
- Use only the type of bulb and maximum wattage indicated by Verilux®.
- Never cover the lamp or place anything on top of it when it is in operation.
- Always unplug lamp before performing bulb replacement.
- Do not use solvents or cleaners containing abrasives, or ammonia based cleaners on this product.
- After cleaning the lamp, all moisture should be properly wiped away and dried before restoring power.
- Dispose of bulbs per local regulations. For more information on clean-up and disposal, see www.epa.gov/cfl.

SAVE THESE INSTRUCTIONS

Features

Your new Verilux HappyLight Compact Energy Lamps are a remarkable product with many features and benefits. It:

- Delivers Natural Spectrum® Daylight to your home, office, dorm room or apartment with no dangerous ultraviolet (UV) waves.
- Has up to 5,000/2,500 LUX* of bright Natural Spectrum light per unit to lift spirits, sharpen concentration and improve energy levels.
- Activates your body's own energy enhancers to make you more alert and productive.
- Is designed with a compact shape and small footprint to make it easy to place in a convenient location.
- Includes an energy efficient, cool-burning 26 Watt 10,000 hour bulb.
- Comes equipped with a convenient on-off power switch on cord.

*5,000 Lux (scotopic measurement) / 2,500 Lux (photopic measurement) @ 6" (per lamp)

Benefits

Verilux HappyLights provide broad spectrum light therapy to stimulate all of the eye's photoreceptors: cones, rods and the newly discovered melanopsin. HappyLights offer photopic light (primarily stimulating the cones) and scotopic light (primarily stimulating the rods) to reduce the size of the pupil, relaxing the eye for more comfortable light therapy. Melanopsin helps set the body's daily cycles and is triggered by Natural Spectrum Light. Scientists have demonstrated that bright light therapy can act like daylight to restore balance, mood and energy.

For more information and research on light therapy, visit www.verilux.com.

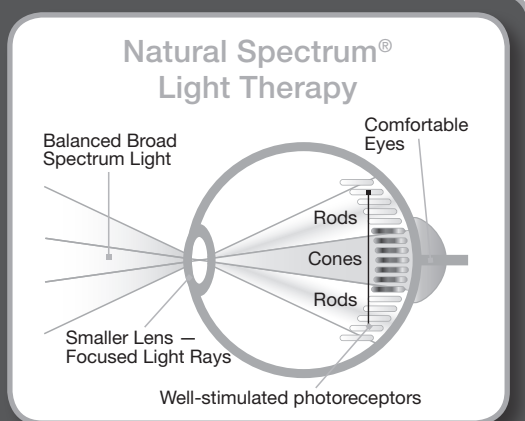

Device Pretest

To help determine if you have sensitivity to light treatment, we recommend that you perform this pretest upon first use of this device:

- Step 1 - Turn on the lamp and position it about 18 inches from your face. (Do not look directly into the lamp.)
- Step 2 - Operate the lamp for approximately 10 minutes and turn it off. If the light from the lamp has caused any discomfort, stop using the lamp and consult a doctor. If you have no discomfort, you may consider gradually decreasing the distance from the lamp and increasing the use time, which results in more lamp intensity and greater effect. For the initial several sessions, you should monitor the degree of any discomfort and accordingly adjust the time used and lamp location.

⚠ WARNING: Some people may experience light sensitivity to fluorescent lighting. Discontinue use if you experience any discomfort.

⚠ WARNING: Certain drugs may induce light sensitivity (e.g., anti-depressants) which may result in discomfort or a level of hyperactivity. Consult with your health care provider before using this product.

⚠ WARNING: If you have a pre-existing eye condition, contact your health care provider prior to use.

Operation

Selecting a Location

- Place your Verilux HappyLight Compact Energy Lamps on a table or other flat surface.
- For best performance, place the HappyLights as close as 6 inches but within 24 inches of your face.

▲WARNING: Do not block vents. Blocking them may cause overheating of the lamp and increase risk of fire.

▲CAUTION : Avoid placing this lamp in areas that are exposed to direct sunlight or close to heat-radiating products such as heaters. Do not place the lamp on top of appliances that radiate heat.

Instructions for Use

Use consists of sitting close to the HappyLight Compact Energy Lamps with your eyes open. While staying oriented toward the light, feel free to engage in other activities such as reading, writing, hobbies and crafts, sewing, needlepoint, applying make-up or working at your computer or desk.

1. Turn on the lamp and allow a few minutes for the bulb to achieve full brightness.
2. The HappyLight Compact Energy Lamps should be positioned as close as 6 inches, but within 24 inches of your face and should be slightly off-center. (See diagram.) *Note: Do not look directly into the lamp.*

The light from the HappyLight Compact Energy Lamps must be directed at your eyes; therefore, your eyes must be open to achieve the full benefit. *Note: Tinted glasses reduce the amount of light reaching your eyes.*

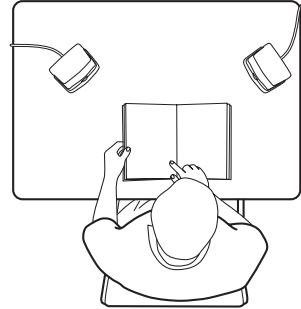

When you are feeling sluggish and lethargic, spend more time with the light, sit closer to it or add more lighting devices to increase the intensity. If you experience edginess or are over stimulated, move the light farther away or reduce use time.

Operation — continued

Minimum Recommended Use



30 minutes
to
1 hour*

Researchers at the National Institute of Health demonstrated that white light, in a range of 2,500 to 10,000 LUX (a measurement of light intensity), helped to reverse the symptoms of “Winter Blues.”

Exposure strategies affect people differently. We all have different reactions to our environment. It is important to establish a distance and schedule that is comfortable for you. We recommend you use the light regularly and at about the same time each day. It is not necessary to sit in front of the lamp continuously. You can divide the time into several mini-sessions. Continue to use the HappyLight daily to feel an improvement in your mood and activity level.

When you are feeling sluggish and lethargic, spend more time with the light, sit closer to the light or add more lighting devices to increase the light intensity. If you feel a sort of edginess, as though you have consumed too much coffee, it may be time to turn off the unit.

* Recommended exposure time is a function of output and distance. Individual results may vary. Also, refer to the warnings at the bottom of page six of this manual.

▲ WARNING: Some people may experience light sensitivity to fluorescent lighting. Discontinue use if you experience any discomfort. Follow directions for pretest on page 6 prior to use.

▲ WARNING: Certain drugs may induce light sensitivity (e.g., anti-depressants) which may result in discomfort or a level of hyperactivity. Consult with your health care provider before using this product.

▲ WARNING: If you have a pre-existing eye condition, contact your health care provider prior to use.

Bulb Removal and Replacement

Your HappyLights® use a bulb manufactured only by Verilux®. To order a replacement bulb, please call Verilux, toll-free, at 1-800-454-4408.

To Replace the Bulb:

1. Unplug the lamp from power outlet. Let the bulb cool down before touching it.

Bulb Removal and Replacement — continued

- To access the bulb, remove the plastic diffuser by pressing the tabs (D) and lifting out the diffuser.
- Firmly hold the bulb base (B) (do not hold the glass portion of the bulb) and turn bulb in a slight counter-clockwise direction until it releases from the socket.

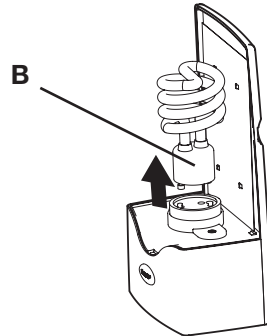
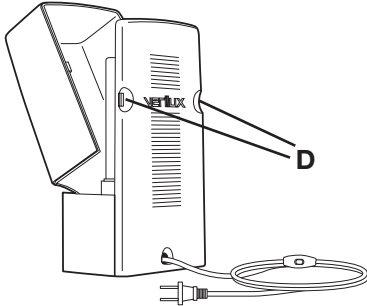

Re-installing Bulb and Plastic Diffuser

- To install the bulb, insert bulb into lamp by firmly holding bulb base and pushing down and rotating slightly in a clockwise direction to seat properly.
- Attach the diffuser to the lamp body by first inserting the tab located at the bottom of the diffuser (A) into the opening of the lamp base (B).
- Insert one diffuser corner at a time into the side track and gently down into place into the bottom track.
- Snap side tab into place on side slot. Entire side of diffuser should be seated into the track. Repeat for other side of diffuser. **Note:** *Alignment of diffuser corner into side track.*
- Firmly push diffuser down until **Tab A** snaps into place. Align top of diffuser in top track as necessary.

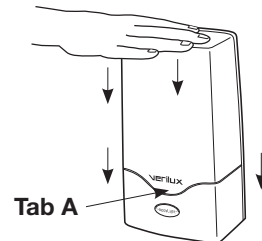
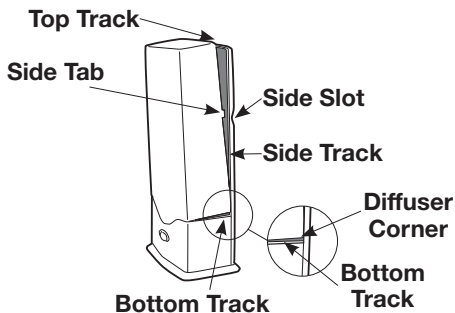
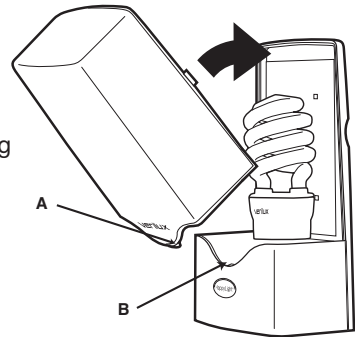

Troubleshooting

Before requesting service on your Verilux lamps, please:

- Make sure all power connectors, cords and plugs are inserted fully and securely.
- Be sure the bulb is securely seated in the socket. (See pages 8 and 9.)
- Make sure there is power to the wall outlet, or try another outlet – one that is not connected to a dimmer.

PROBLEM	CHECK	SOLUTION
Light Won't Come On	Has the plug come loose?	Insert plug securely into wall outlet.
	Is the bulb old?	Check bulb for blackening/darkening at bottom of spiral where it joins the base (an indicator of bulb life) and replace bulb.
	Is the bulb connected securely into socket?	Be sure the bulb is securely seated in the socket. Repeat the bulb installation process. ⚠ CAUTION: Always unplug lamp before performing bulb replacement or installation.
Blackening/Darkening at Ends of Bulb	Is the bulb new?	Sometimes when a new bulb is turned on for the first time the tubing will darken, but this will fade after a few minutes.
	Is the bulb old?	With older bulbs, darkening of the tubing indicates end of bulb life. (This doesn't affect operation except to reduce the amount of light available, since the phosphor in that area has become inactive.) Bulb replacement is recommended.
Light Flickers	Has the plug come loose?	Insert plug securely into wall outlet.
	Is the bulb connected securely to the socket?	Be sure the bulb is securely seated into the socket. Repeat the bulb installation process. ⚠ CAUTION: Always unplug lamp before performing bulb replacement or installation.
	Is the lamp connected to a dimmer switch?	Connect lamp plug only to wall outlet without dimmer switch.

Care and Cleaning

Your Verilux lamps are made from high-quality materials that will last for many years with a minimum of care.

⚠ WARNING: To prevent risk of shock or personal injury when cleaning lamp, make sure you have turned off and unplugged the lamp and allowed sufficient time for the bulb to cool.

⚠ CAUTION: Clean only with a soft dry cloth – do not use solvents or cleaners containing abrasives or ammonia.

⚠ CAUTION: After cleaning the lamp, wipe away all moisture and let the lamp dry completely before restoring power.

Technical Specifications

HappyLight Compact Energy Lamp Twin Pack

Environment

Operating Temperature: 15 to 35°C (56 to 95°F)

Storage Temperature: 0 to 40°C (32 to 104°F)

Relative Humidity: 5 to 95% non-condensing

Bulb

Replacement bulb: 26 Watt 10,000 hour bulb.

Replace with Verilux brand only, Model number CFS26GU24VLX by calling 1-800-454-4408 or visiting www.verilux.com.

Power

Input Power: 120 VAC, 60Hz, 0.50 A

UL Listed in Canada and the USA

In Love with the Light?

The benefits of Verilux lighting are available in a range of products — all designed to help you live **life in a better light**:

■ Get Back to Being You

Products to Improve Skin, Mood, Energy and Well Being

■ Don't Clean, Sanitize

Wands and Vacuums that Use UV-C Rays to Banish Germs, Odors and other Nasties

■ Productivity Lighting

Lamps that Use Natural Spectrum Light so You Can Read, Task, Work and Excel

■ Fix Your Fixtures

Natural Spectrum Bulbs and Tubes to Illuminate Your Home, Work and Life

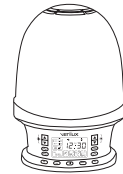

Rise & Shine® Natural Wake-Up Light

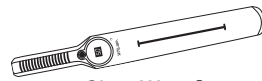

CleanWave® Sanitizing Wand

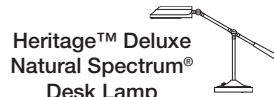

Heritage™ Deluxe Natural Spectrum® Desk Lamp



A wide assortment of Natural Spectrum Bulbs and Tubes for all over your home

For more information, to order, or to find a retailer near you, visit us at www.verilux.com or call 1-800-786-6850.

One Year Limited Warranty

ATTENTION! ONCE OPENED, PLEASE **DO NOT** RETURN THIS PRODUCT TO THE STORE WHERE IT WAS PURCHASED FOR REPAIR OR REPLACEMENT!

Many questions can be answered by visiting www.verilux.com, or you may call our Customer Service Department at 1-800-786-6850 during normal business hours.

This limited warranty is provided by Verilux, Inc., 340 Mad River Park, Waitsfield, VT 05673

Verilux warrants this product to be free from defects in material and workmanship for a period of one year from the date of the original retail purchase from Verilux or an authorized Verilux distributor. **Proof of purchase is required for all warranty claims.** During the limited warranty period, Verilux, Inc., will, at its option, repair or replace defective parts of this product at no charge to the customer, subject to these limitations: This limited warranty does not include any postage, freight, handling, insurance or delivery fees. This warranty does not cover damage, defect or failure caused by or resulting from accident, external destruction, alteration, modification, abuse, misuse or misapplication of this product.

This warranty does not cover damage to the product resulting from return shipping or handling. Shipping insurance is recommended to help protect your product.

Return Authorization is required for all returns. To obtain a Return Authorization, please contact the Verilux Customer Service Department at 1-800-786-6850.

If, during the first year of ownership, this product fails to operate properly, it should be returned as specified at www.verilux.com/warrantyreplacement or as instructed by a Verilux customer service representative at 1-800-786-6850.

Note: *Verilux recommends using a quality surge suppressor on all electronic equipment. Voltage variations and spikes can damage electronic components in any system. A quality suppressor can eliminate the vast majority of failures attributed to surges. Suppressors may be purchased at electronics stores.*

Due to ongoing improvements, actual product may have slight variations from the product described in this manual.

Please visit our website at: www.verilux.com or call our Customer Service Department at

1-800-786-6850

Representatives are available Monday – Friday, 9am – 5pm EST

verilux®

340 Mad River Park, Waitsfield, VT 05673