

Magnifier

For Original and EasyFlex® Floor Lamps

Model: VM01

Job#: 0.0	Title: VM01 Manual
Date: 10/06/14	Version: Rev5



Dear Customer,

Thank you for purchasing the Verilux Deluxe Magnifier. You now own an innovative product, manufactured to the highest standards and backed by a one-year limited warranty.

Many other healthy-lighting products are available through our catalog and online. Visit us on the web at www.verilux.com to request a free catalog and learn more about all our quality Verilux products, or call us toll-free at 1-800-454-4408.

As a Verilux customer, your satisfaction means everything to us. We look forward to serving you now and in the future.

Have a bright day!

A handwritten signature in black ink that reads "Nicholas Harmon". The signature is written in a cursive, flowing style.

Nicholas Harmon
President, Verilux, Inc.

MAGNIFIER PARTS

Main Parts

- A. Handle
- B. 2X Magnifier Lens
- C. 6X Spot Lens
- D. Gooseneck Arm
- E. Clamp Assembly
- F. Tightening Knob

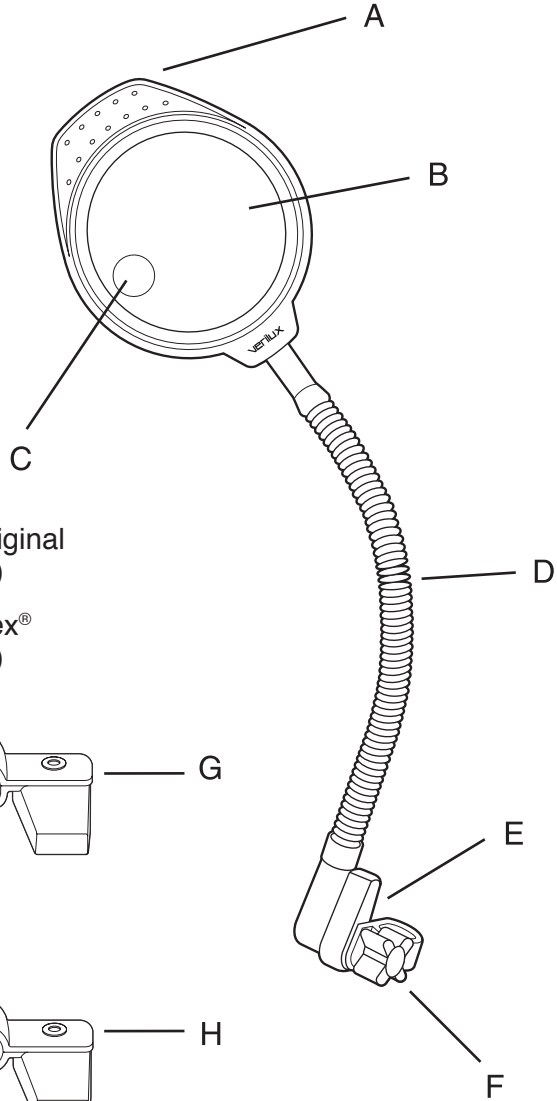

Additional Parts

- G. Adapter clamp for Original Deluxe Floor Lamp (VF01)
- H. Adapter clamp for EasyFlex® Deluxe Floor Lamp (VF02)

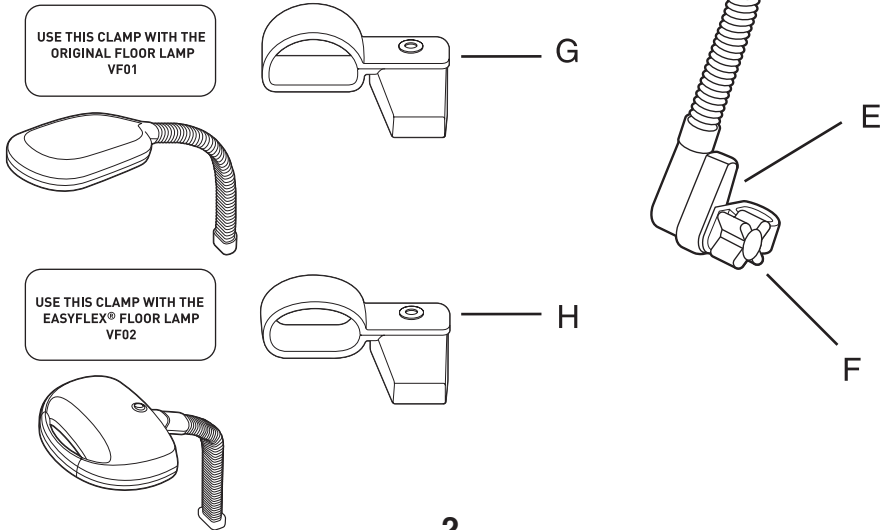

2

Job#: 0.0	Title: VM01 Manual
Date: 10/06/14	Version: Rev5

INSTRUCTIONS FOR ATTACHMENT

To attach the Verilux® Deluxe Magnifier to your floor lamp:

1. Remove magnifier from packaging.
2. Locate the adapter clamp that corresponds to your Verilux® Floor Lamp model.
3. Open the adapter clamp wide enough to fit around the lamp shaft (Fig 1).
4. Snap clamp in place at the desired mounting height (Fig 2).
5. Unscrew and remove the tightening knob on the end of the magnifier arm by turning counterclockwise.
6. Insert the magnifier into the adapter clamp and secure with the tightening knob, turning clockwise (Fig 3).
7. Remove the protective film from magnifier lens and wipe lens clean with the microfiber dusting cloth.

NOTE: Do not attach magnifier to logo area on lamp shaft, or to gooseneck.

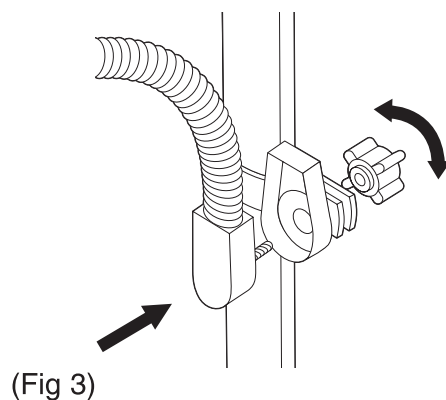
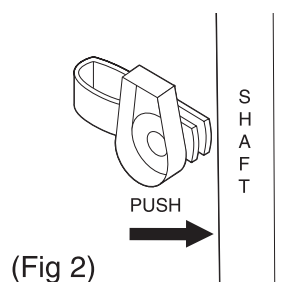
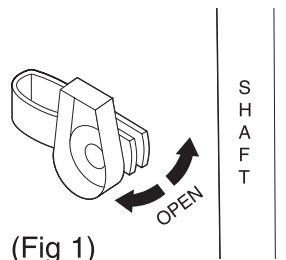

ADJUSTING THE MAGNIFIER

1. Turn the tightening knob counterclockwise to loosen the adapter clamp.
2. While holding the lamp shaft steady, slide the adapter clamp up or down to the desired position.
3. Turn the tightening knob clockwise to secure.
4. Use the magnifier handle to position the magnifier as needed.

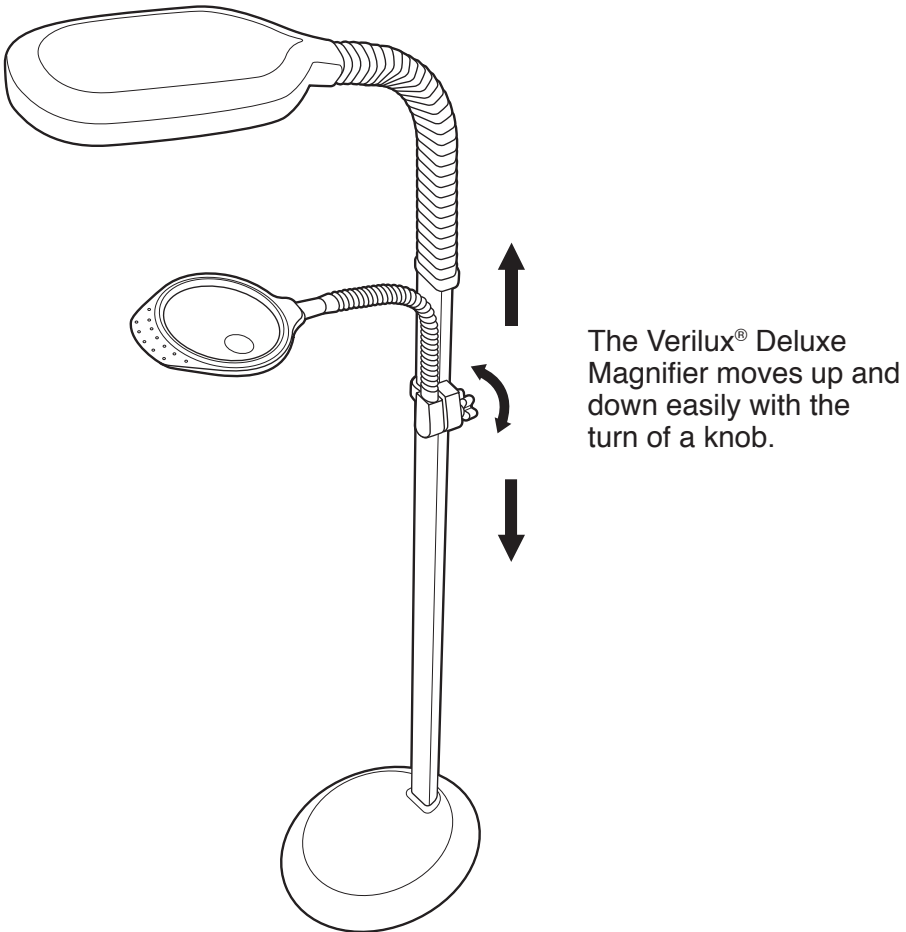

4

Job#: 0.0	Title: VM01 Manual
Date: 10/06/14	Version: Rev5

CARE & CLEANING

NOTE: *The lens is made of optical quality acrylic. To avoid scratches clean only with the microfiber dust cloth, or unplug lamp and use a soft cloth and warm soapy water.*

NEVER USE ABRASIVE CLEANERS OR AMMONIA-BASED WINDOW CLEANER.

IMPORTANT SAFETY INFORMATION



WARNING - RISK OF FIRE!

Never leave the lens in direct sunlight or place in a position where direct sunlight can shine through the magnifier.

One-Year Limited Warranty

ATTENTION! ONCE OPENED, PLEASE **DO NOT** RETURN THIS PRODUCT TO THE STORE WHERE IT WAS PURCHASED FOR REPAIR OR REPLACEMENT!

Many questions may be answered by visiting www.verilux.com, or you may call our Customer Service Department at 800-786-6850 during normal business hours.

This limited warranty is provided by: Verilux, Inc., 340 Mad River Park, Waitsfield, VT 05673

Verilux warrants this product to be free from defects in material and workmanship for a period of 1 year from the date of the original retail purchase from Verilux or an authorized Verilux distributor. **Proof of purchase is required for all warranty claims.** During the limited warranty period, Verilux Inc., will, at its option, repair or replace defective parts of this product, at no charge to the customer, subject to these limitations: This limited warranty does not include any postage, freight, handling, insurance or delivery fees. This warranty does not cover damage, defect or failure caused by or resulting from accident, external destruction, alteration, modification, abuse, misuse or misapplication of this product.

This warranty does not cover damage to the product resulting from return shipping or handling. Verilux recommends purchasing shipping insurance to protect your investment.

Return Authorization is required for all returns. To obtain a Return Authorization, please contact the Verilux Customer Service Department at 800-786-6850.

If, during the first year of ownership, this product fails to operate properly, it should be returned as specified at www.verilux.com/warrantyreplacement or as instructed by a Verilux customer service representative at 800-786-6850.

Note: *Verilux recommends using a quality surge suppressor on all electronics equipment. Voltage variations and spikes can damage electronic components in any system. A quality suppressor can eliminate the vast majority of failures attributed to surges and may be purchased at electronics stores.*

Due to ongoing improvements, actual product may have slight variations from the one described in this manual.

Job#: 0.0	Title: VM01 Manual
Date: 10/06/14	Version: Rev5

Please visit our web site at: www.verilux.com or call

1-800-786-6850

Representatives are available Monday – Friday 9:00a.m to 5:00p.m. EST

verilux®

340 Mad River Park, Waitsfield, VT 05673