



1

GP-L15/x is an additional wiring loom that also contains an identifier tag to identify the car as Car 2, Car 3, or Car 4. GaugePilot can store independent configurations and calibrations for up to 4 different cars. Purchase GP-L15/2 for car 2, GP-L15/3 for car 3, or GP-L15/4 for car 4.*

The Car ID tag is already installed in the Brown plug and the only additional installation step required over a standard install is to enable the CarID feature in your GaugePilot in Setup->Preferences->General for your GaugePilot to make use of it.*

*Except Clubman model - Purchase GP-15/1 as a spare loom for a Clubman (without CarId) but it will NOT store independent settings or configurations.

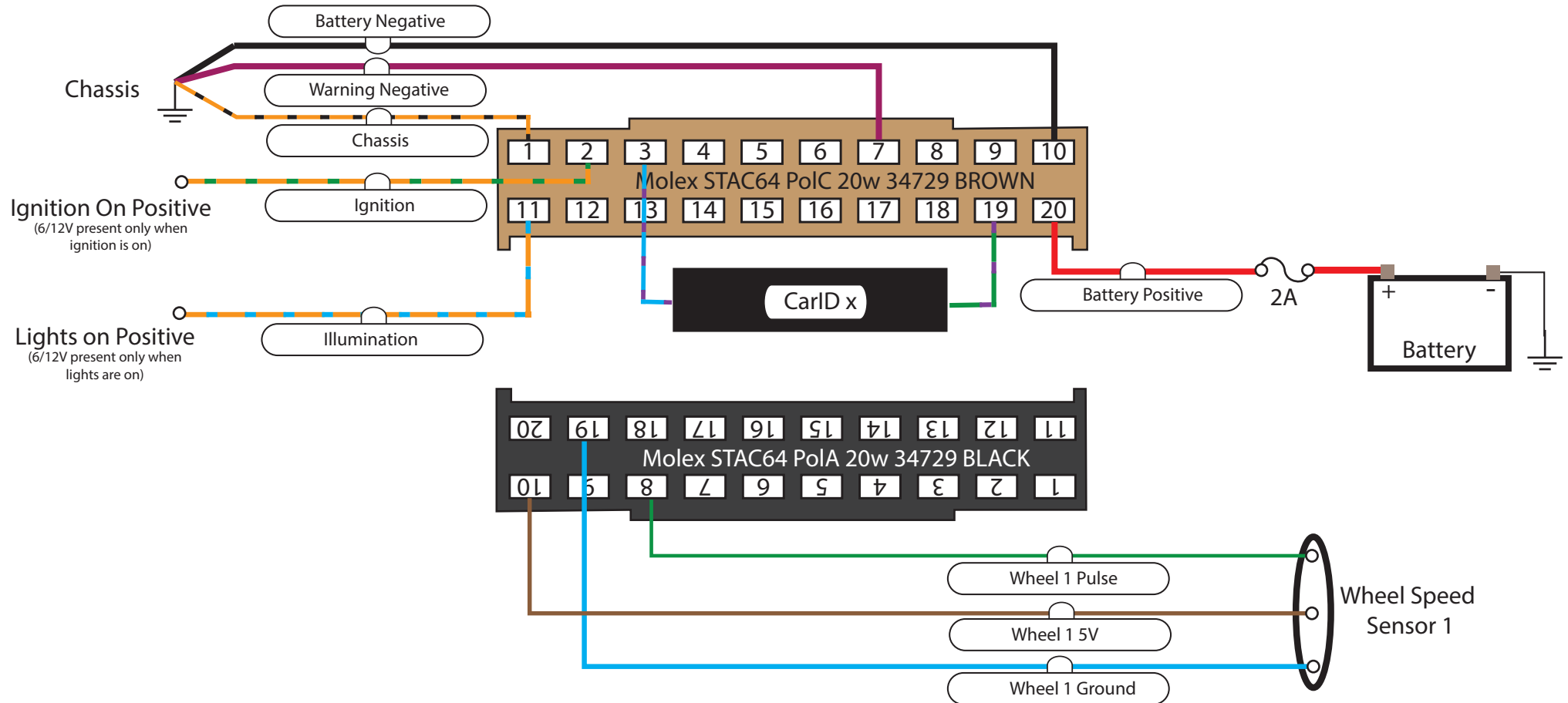

Negative Earth Vehicles ONLY
See sheet 2 for positive earth

GP-L15/x Additional Car Loom

Sheet 1 of 8 | 16th September 2016 Revision: R1
30th March 2016 | (c) 2016 Hambly Industries Limited

GaugePilot





1

GP-L15/x is an additional wiring loom that also contains an identifier tag to identify the car as Car 2, Car 3, or Car 4. GaugePilot can store independent configurations and calibrations for up to 4 different cars. Purchase GP-L15/2 for car 2, GP-L15/3 for car 3, or GP-L15/4 for car 4.*

The Car ID tag is already installed in the Brown plug and the only additional installation step required over a standard install is to enable the CarID feature in your GaugePilot in Setup->Preferences->General for your GaugePilot to make use of it.*

*Except Clubman model - Purchase GP-15/1 as a spare loom for a Clubman (without CarId) but it will NOT store independent settings or configurations.

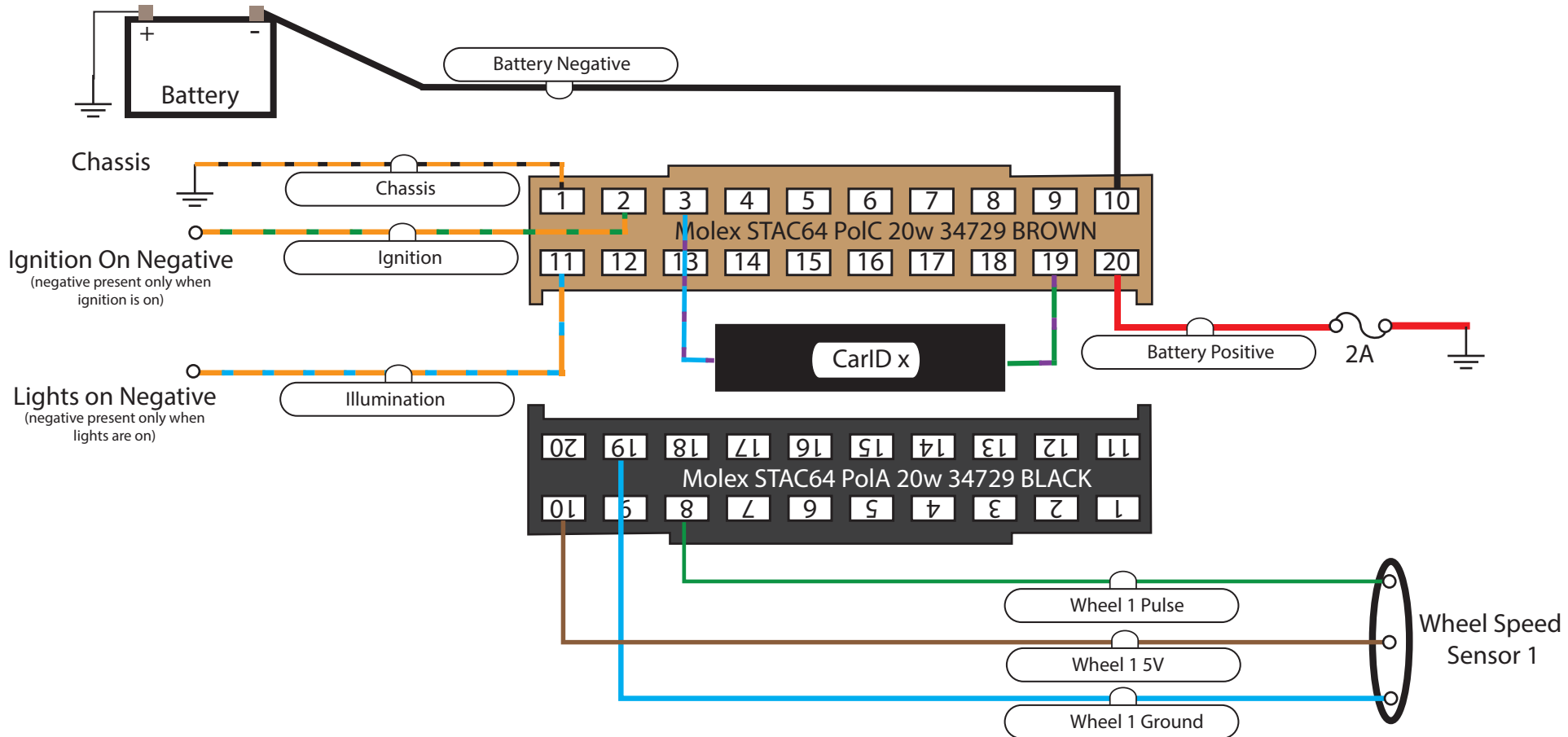

Positive Earth Vehicles ONLY
See sheet 1 for negative earth

GP-L15/x Additional Car Loom

Sheet 2 of 9 | 16th September 2016 | Revision: R1

(c) 2016 Hambly Industries Limited



GaugePilot Connector Pin / Loom Colour	Sensor Signal	Sensor Wiring / Terminal Colour					
		GaugePilot GP-S04	Brantz BR1	Brantz BR4	Monit* Sensor PR001-EN	Monit Sensor (Early)	TerraTrip T006
		M12x1	Speedo Drive	Gearbox Drive	M12x1	M12x1	Speedo Drive
A10 Brown	5V	Brown	Brown	Red	Brown	Orange	Red
A8 Green	Pulse	Black	Blue	White	Black	Blue	White
A19 Blue	Ground	Blue	Green	Black	Blue	Black	Black (Shield)

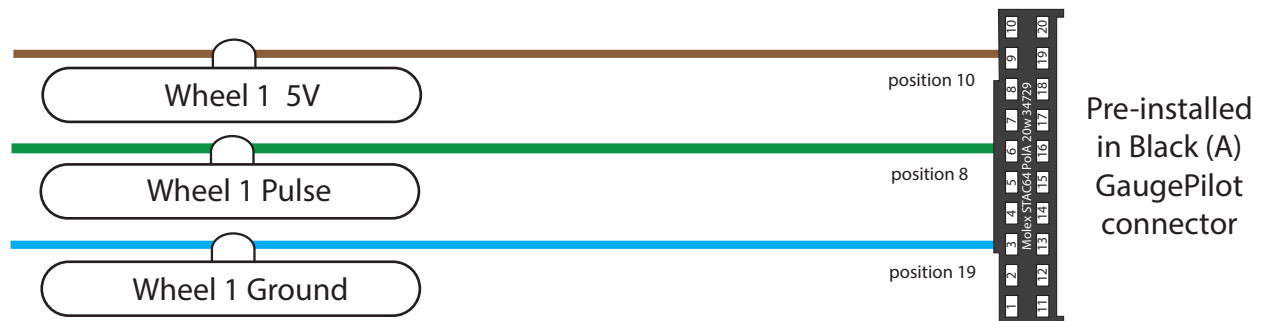
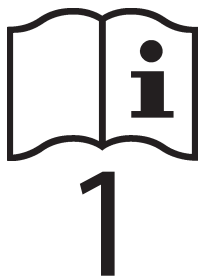

*The new Monit sensors are designed for 12V operation, rather than the 5V of their predecessor. We have not had any reported issues from users using their existing Monit sensor with GaugePilot but please ensure that your odometer is behaving consistently after installation.

Note that our GP-S04 sensor is physically interchangeable with the Monit PR001-EN and guaranteed for 5V operation.

Do not connect an externally powered sensor directly to Wheel 1 Pulse. Contact GaugePilot for a suitable isolating interface adaptor (GP-SAx) for the voltage that your externally powered sensor provides. GP-SA01, as required with our external GPS pulse sensor, is suitable for 5V signals.

Wheel Sensor 1 Connection



Sheet 3 of 8

30th March 2016 Revision: R2

(c) 2016 Hambly Industries Limited



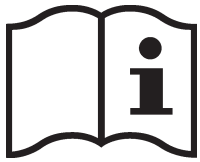

2

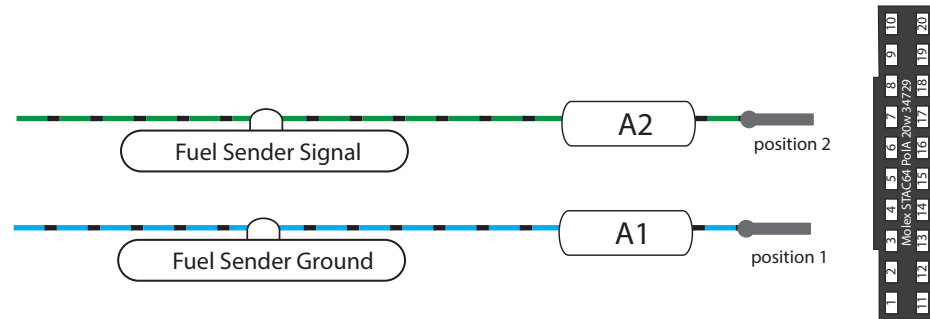

Insert into Existing Black (A) GaugePilot connector

Labelled GREEN/BLACK and BLUE/BLACK wires with crimped terminals are provided with our wiring looms, for insertion into the BLACK connector.

GaugePilot operates with a wide range of sender impedances and contains an internal current source.

Do not connect the fuel sender to any other device or Gauge when connecting it to GaugePilot. Doing so may damage either GaugePilot, the other device, or both.

See the Molex document in our resources area at www.gaugepilot.uk for how to insert pins into the GaugePilot Black (A) connector.

Fuel Sender

Sheet 4 of 8

30th March 2016 Revision: R1

(c) 2016 Hambly Industries Limited

GaugePilot



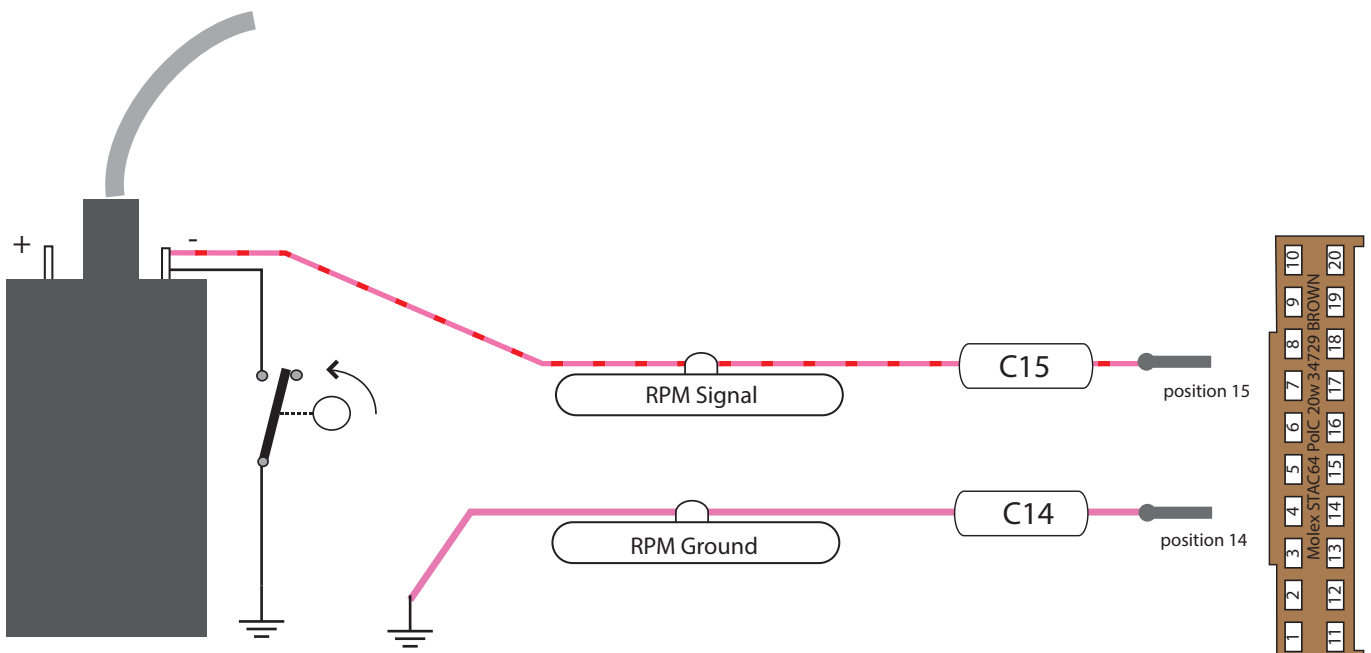

Insert into Existing Brown (C) GaugePilot connector

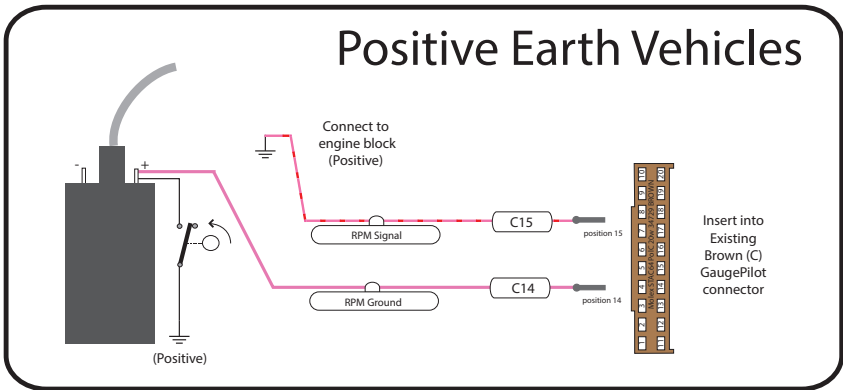

Labelled PINK and PINK/RED wires with crimped terminals are provided with our wiring looms, for insertion into the BROWN connector
Connected as shown GaugePilot supports high-level input signals from the Low Tension side of the ignition coil
By connecting the RPM signal wire to pin A5 (BLACK connector) instead of C15 (BROWN connector), low-level input signals from an ECU or CDI box can be used as an alternative.

See the Molex document in our resources area on www.gaugepilot.uk for how to insert pins into the GaugePilot Brown connector

Negative Earth Vehicles
See inset diagram for positive earth





4

Navigator Button
(Push to make)

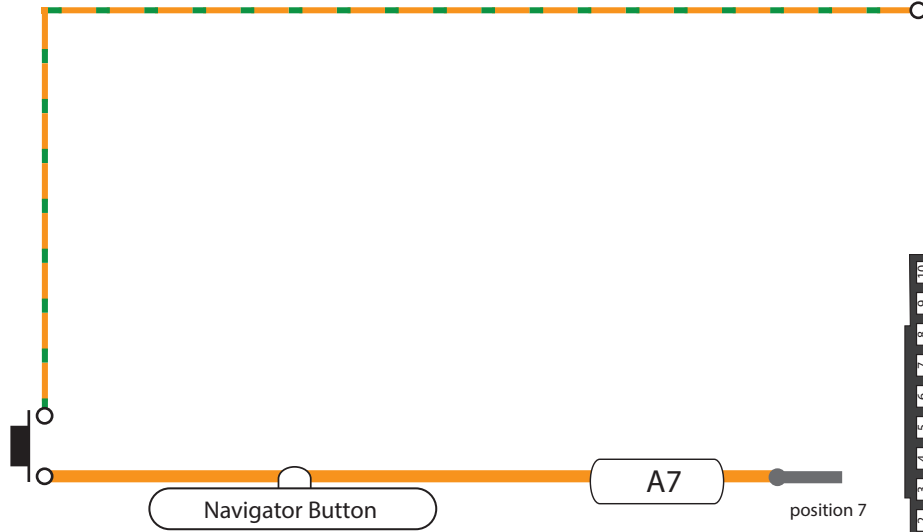

Connect to the same location
as the ORANGE/GREEN wire
that connects to pin 2 of
connector C (BROWN)

Insert into
Existing
Black (A)
GaugePilot
connector

A labelled ORANGE wire with crimped terminal is provided in wiring pack 4 , for insertion into the BLACK (A) connector **if you are using your own switch.**

GP-A04 is a high quality accessory handheld switch on a curly cord with an IP68 rated connector. It can be supplied with either an in-line (I) or panel mounted (P) connector for the vehicle-side connection, and comes complete with its own wiring for insertion into position 7.

Do not insert the ORANGE wire provided with the wiring loom if using GP-A04 but use the its pre-attached wiring instead.

See the Molex document in our resources area on www.gaugepilot.uk for how to insert pins into the GaugePilot Black connector.

Navigator Button

Sheet 6 of 8

30th March 2016 Revision: R2

(c) 2016 Hambly Industries Limited

GaugePilot



GaugePilot Connector Pin / Loom Colour	Sensor Signal	Sensor Wiring / Terminal Colour					
		GaugePilot GP-S04	Brantz BR1	Brantz BR4	Monit* Sensor PR001-EN	Monit Sensor (Early)	TerraTrip T006
		M12x1	Speedo Drive	Gearbox Drive	M12x1	M12x1	Speedo Drive
A9 Brown	5V	Brown	Brown	Red	Brown	Orange	Red
A6 Green/Blue	Pulse	Black	Blue	White	Black	Blue	White
A20 Blue	Ground	Blue	Green	Black	Blue	Black	Black (Shield)

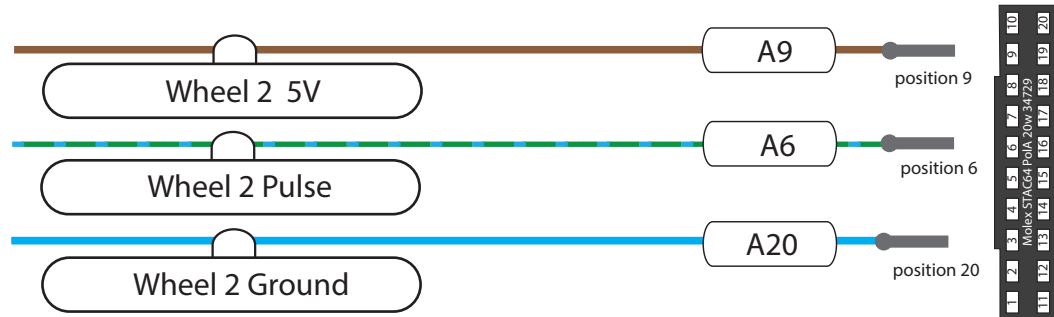

Insert into Existing Black (A) GaugePilot connector

*The new Monit sensors are designed for 12V operation, rather than the 5V of their predecessor. We have not had any reported issues from users using their existing Monit sensor with GaugePilot but please ensure that your odometer is behaving consistently after installation.

Note that our GP-S04 sensor is physically interchangeable with the Monit PR001-EN and guaranteed for 5V operation.

Labelled BROWN, BLUE, and GREEN/BLUE wires with crimped terminals are provided in wiring pack 4, for insertion into the BLACK connector, if using a second sensor.*

Do not connect an externally powered sensor directly to Wheel 2 Pulse. Contact GaugePilot for a suitable isolating interface adaptor (GP-SAxx) for the voltage that your externally powered sensor provides. GP-SA01, as required with our external GPS pulse sensor, is suitable for 5V signals.

* Classic model does not support wheel sensor 2

Wheel Sensor 2 Connection*

Sheet 7 of 8

30th March 2016 Revision: R2

(c) 2016 Hamby Industries Limited

GaugePilot



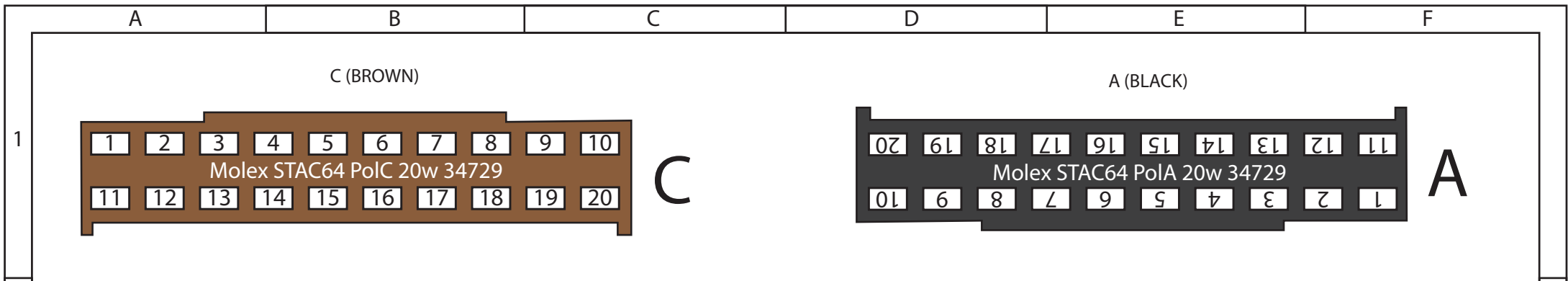

Pin	I/O	Label	Wire Colour (Primary/Stripe)	Provided With	Note	Pin	I/O	Signal	Wire Colour (Primary/Stripe)	Provided With	Note
C1	-	Chassis	ORANGE/BLACK	L	signal return for IG/LUM/NAV	A1	-	Fuel Ground	BLUE/BLACK	I	
C2	I	Ignition	ORANGE/GREEN	L	Chassis (C1) provides return path	A2	I	Fuel Signal	GREEN/BLACK	I	10mA current source
C3	-	CarID Ground*	BLUE/PURPLE	W		A3	-	Temperature 2 Ground*	BLUE/WHITE	A	
C4	-	Pressure Ground	BLUE/YELLOW	A		A4	-	n/c			
C5	O	Pressure 5V	BROWN/YELLOW	A	5V 20mA	A5	I	RPM LOW signal			low-level input (alternative to C15)
C6	O	Slave On	GREY	A	For GaugePilot accessory use only	A6	I	Wheel 2 Pulse#	GREEN/BLUE	I	
C7	-	Warning Negative	PURPLE	A	Warning 1/2 ground	A7	I	Navigator Button	ORANGE	I	Chassis (C1) provides return path
C8	O	Warning 1	PURPLE/PINK	A	1A	A8	I	Wheel 1 Pulse	GREEN	L	
C9	O	Warning 2	PURPLE/RED	A	1A	A9	O	Wheel 2 Power#	BROWN	I	5V 20mA
C10	-	Battery Negative	BLACK	L		A10	O	Wheel 1 Power	BROWN	L	5V 20mA
C11	I	Illumination	ORANGE/BLUE	L	Chassis (C1) provides return path	A11	-	CANbus Ground*	YELLOW/BLACK	A	
C12	-	Temperature 1 Ground	BLUE/RED	A		A12	I/O	CANbus L*	YELLOW/RED	A	
C13	I	Temperature 1 Signal	GREEN/RED	A	Internal pull-up	A13	I/O	CANbus H*	YELLOW	A	
C14	I	RPM Ground	PINK	I		A14	I	Pressure Signal	GREEN/YELLOW	A	0-5V
C15	I	RPM Signal	PINK/RED	I	high-level LT input	A15	I	Temperature 2 Signal*	GREEN/WHITE	A	Internal pull-up
C16	I	RS232 2 IN*	LT GREEN	A		A16	I	RS232 1 IN*	WHITE	A	
C17	-	RS232 2 GND*	LT GREEN/BLACK	A		A17	-	RS232 1 GND*	WHITE/BLACK	A	
C18	O	RS232 2 OUT*	LT GREEN/PINK	A		A18	O	RS232 1 OUT*	WHITE/PINK	A	
C19	I	CarID Signal*	GREEN/PURPLE	W		A19	-	Wheel 1 Ground	BLUE	L	
C20	I	Battery Positive	RED	L		A20	-	Wheel 2 Ground#	BLUE	I	

- L = Pre-installed in provided wiring pack and in GP-L15/x wiringlooms for additional vehicles
- W = Pre-installed in GP-L15/2, GP-L15/3 and GP-L15/4 wiringlooms for additional vehicles
- I = provided pre-crimped with wiring pack and in GP-L15/x accessory looms for insertion if signal is required
- A = pre-crimped wire supplied with additional accessories that make use of this signal and not as part of provided wiring looms

Connectors and crimps available as GP-L01 if you or your installer wish to make your own wiring loom from scratch

* Clubman models do not support Temperature 2, RS232 1, RS232 2, or CANbus.
 # Classic models do not support wheel sensor 2

<h1>Pin List</h1>		 HAMBLY INDUSTRIES
Sheet 8 of 8	16th September 2016 Revision: R3	
(c) 2016 Hambly Industries Limited		