

# PRODUCT INFORMATION



MANUFACTURER: SUBARU  
 YEAR: 2022+  
 MODEL: WRX  
 TRIM: -  
 CHASSIS CODE: VB  
 REMARK PART #: RO-TSVB-R1D / RO-TTVB-R1D  
 DESCRIPTION: AXLEBACK R1-DUAL STAINLESS STEEL - STAINLESS, BURNT FINISH

## PARTS LIST

No.	Description	Part Num.	Qty	Torque
1	2.5" Metal 2-Bolt Gasket	65M2-S02	2	
2	M10 Serrated Hex Head Bolt L=40mm	M10B40	4	~42 ft-lbs.
3	M10 Serrated Nut	M10N	4	~42 ft-lbs.
A	Rear Section Right	N/A	1	
B	Rear Section Left	N/A	1	

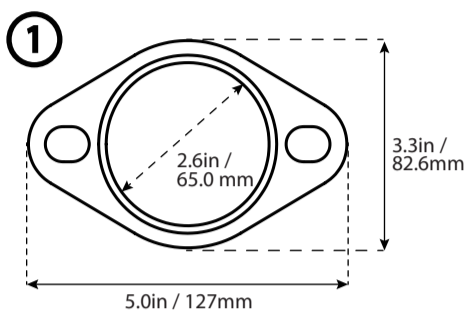

## PARTS LAYOUT

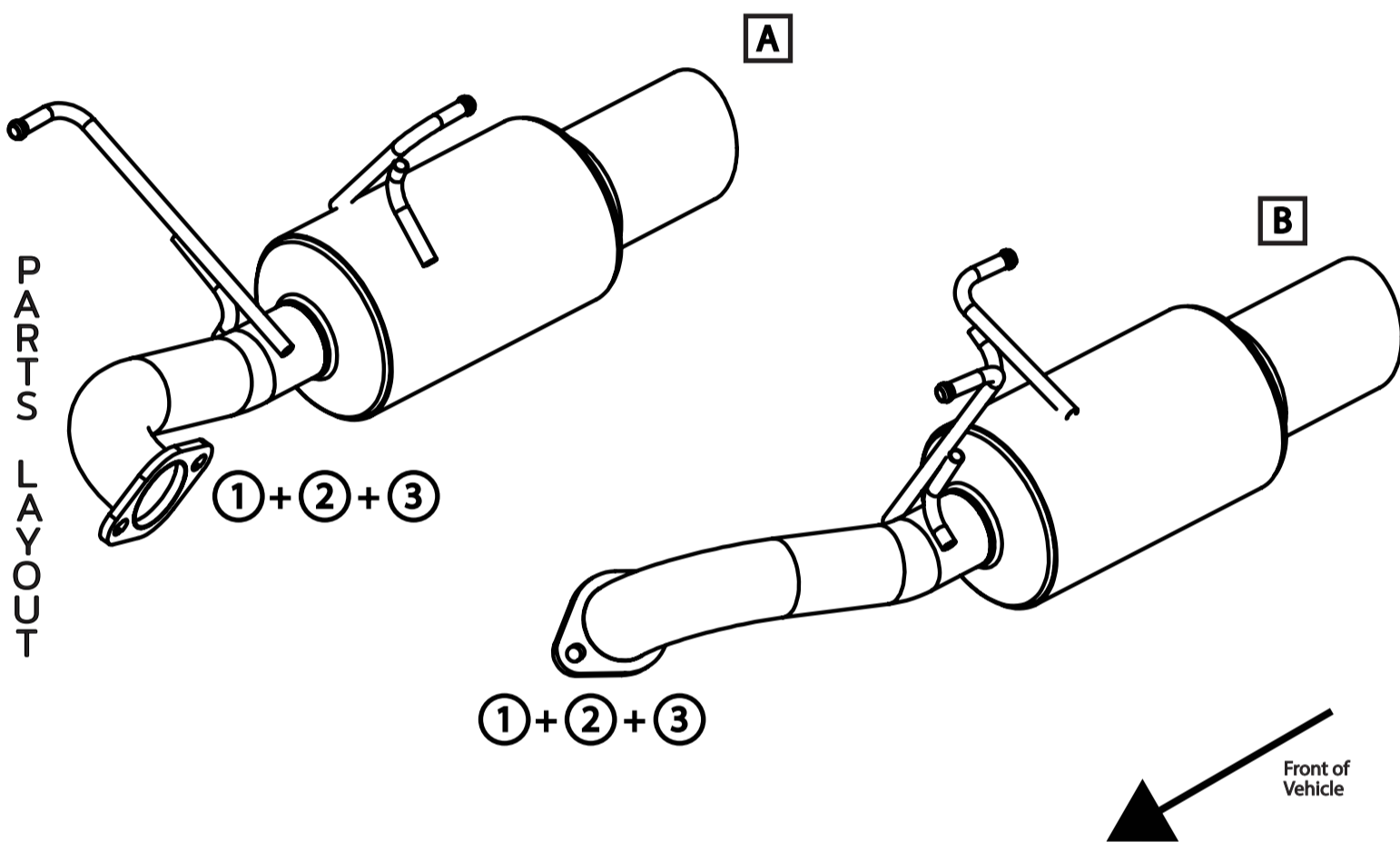

## INSTALLATION

- We recommend installation to be performed by a trained and/ or qualified technician.
- Remove OEM rear muffler sections
- Remove OEM donut style gaskets from the midpipe
- Install REMARK exhaust components using the original rubber hangers unless otherwise noted.
- Install all gaskets and hardware. Leave the hardware hand tight.
- Align flanges, gasket, and snug all hardware so that sections cannot move.
- Check positioning of the exhaust piping, and tips(s). Reposition if needed by loosening hardware, adjust position and retighten hardware.
- When placement is confirmed, tighten all hardware to recommend torque spec.
- Gently shake/ move the exhaust system to ensure there is proper clearance around the entire system, especially the tips to bumper.
- Thoroughly wipe down the exhaust system from any grease, dirt, handprints, fingerprints, etc... as these may cause a permanent stain once the exhaust reaches operating temp.  
**NOTE: We suggest wiping the tip with carwash soap and water, especially if you have tips with color treatment such as BURNT, BURNED, BLUE, BLACK. Some cleaners can discolor, and/ or damage the finish.**
- Start the engine
- Check for any leaks, fitment issues, rubbing, etc..
- Re-check for exhaust leaks, fitment issues, and re-torque all hardware after ~100 miles of driving.

## WARRANTY POLICY

- 1-year limited manufacturer defect warranty from date of purchase
- All warranty claims are subject to inspection by REMARK at our facility
- Limited Warranty only applies to the original purchaser of the product
- REMARK is not responsible for fitment issues on non-US spec vehicles as all products are developed on US spec models
- Product finishes are not covered under warranty and considered wear & tear
- No warranty whatsoever will be valid if the defect was caused by abuse, negligence and/or mishandling. That includes weather conditions, natural disasters, any road/off-road conditions, and any accidents/collision you were part of.
- Acidic cleaning products or steel wool are not to be used unless by a trained professional. Some chemical cleaning products may damage the product and/or finishes.
- Wear and tear (the damage that happens to our product in ordinary use) is not covered by our limited warranty.
- Improper installation or misuse of the product may lead to failure and damage to both product and vehicle. The user assumes all responsibility.
- All products are intended for use off-public streets and highways. Vehicle manufacturer warranty may be voided should any modification(s) or removal(s) of OEM(factory) components are determined.
- Federal and state law may prohibit the removal, modification or rendering of any device affecting vehicle emissions or state regulated decibel limits. It is the customer's responsibility to be aware of federal, state and local laws.
- User assumes all cost and risks associated with purchase and installation of aftermarket components. REMARK is not responsible for any fees, fines, or any type of penalties you have received from any authority.
- Buyers are responsible for all return shipping fees unless otherwise noted
- REMARK does not cover any installation, un-installation, labor fees, or related