

PRODUCT INFORMATION SHEET



MANUFACTURER: TOYOTA
 YEAR: 2023+
 MODEL: GR COROLLA
 TRIM:
 CHASSIS CODE: GZEA14
 REMARK PART #: RK-C4076T-05
 DESCRIPTION: CATBACK CONFIG - 3.0 IN / 304 STAINLESS STEEL CONSTRUCTION / QUAD TIPS

No.	Description	Part Num.	Qty	Torque
1	3.0" Composite 2-Bolt Gasket	76C2-01	1	
2	M10x1.5 Serrated Hex Head Bolt L=35mm	M10B35	2	~42 ft-lbs.
3	M10x1.5 Serrated Nut	M10N	2	~42 ft-lbs.
A	3.0" Resonated Midpipe	N/A	1	
B	Rear Muffler Section	N/A	1	
B	Titanium Tip Cover, 4.5"	RK-AT115-T	1	
B	M5 Buttonhead Bolt, M5x0.8, L= 8mm	N/A	3	~40 inch-lbs.

PARTS LIST

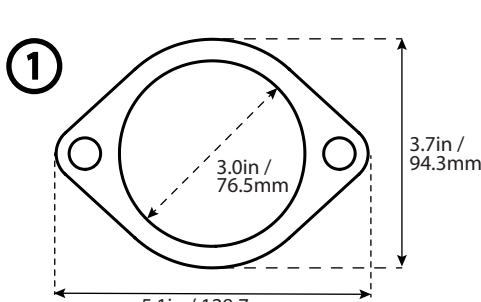

PARTS LAYOUT

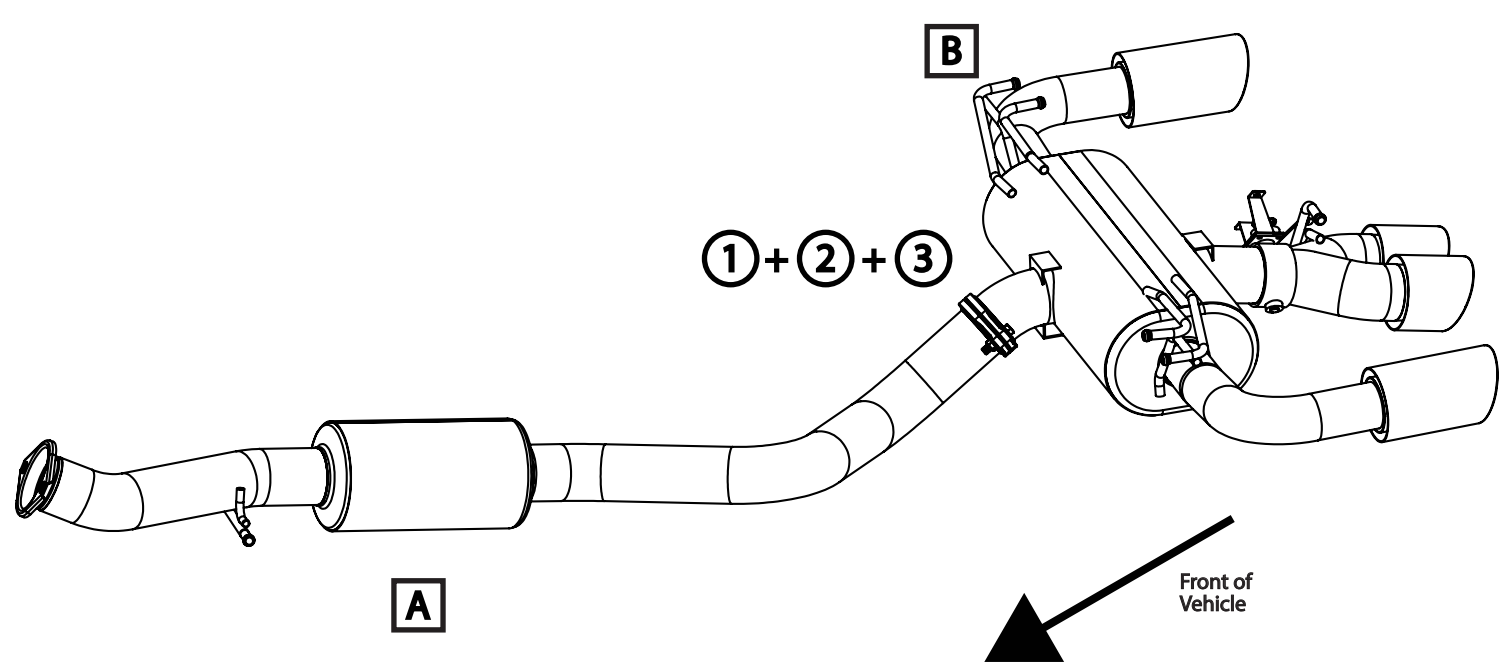

INSTALLATION

IMPORTANT: INSTALLATION OF THIS PRODUCT REQUIRES MODIFICATION OR REPLACEMENT OF OEM REAR BUMPER COVER

- We recommend installation to be performed by a trained and/ or qualified technician
- Disconnect Negative terminal from the battery
- Unplug electrical connector from OEM exhaust valve
- Unclip OEM exhaust valve electrical harness from exhaust
- Remove OEM exhaust and or exhaust components
- Remove OEM exhaust valve motor and base plate from the OEM exhaust system as one unit.
Remove the three M8 bolts



- From the REMARK exhaust, section B, remove the three M6 bolts, three M6 nuts, and plate at the exhaust valve.
SHOWN IN RED IN THE IMAGE
These parts are only used to prevent the brackets from being damaged or bent in shipping.
The flat plate and M6 hardware will **not** be reused



- The exhaust valve in the REMARK exhaust is spring loaded and is closed at rest. To properly install the OEM exhaust valve motor, we need to ensure the valve and motor are properly aligned.
To do this, we need to manually open the exhaust valve by rotating the actuator plate clockwise until the exhaust valve is fully open. Use a wooden or plastic object to keep the REMARK exhaust valve open. The handle of a large screwdriver, handle of a mallet, etc... will work without issue)



- Line up the two prongs of the valve motor, to the two slits in actuator plate. If the valve is fully open, the valve motor assembly should closely line up with the three bracket holes. Secure valve motor assembly to exhaust valve bracket with the original M8 hardware.
Torque to factory spec or ~20 ft-lbs



- Ensure the exhaust valve position is correct by looking into the center tips, the exhaust valve should be in an open position
 - Install REMARK exhaust components using the original rubber hangers
 - We recommend starting from the front first and working your way rearwards.
 - Reuse the OEM bolt and spring for the connection between OEM front pipe and REMARK midpipe
 - Install all gaskets and hardware. Leave the hardware hand tight.
 - Align flanges, gasket, and snug all hardware so that sections cannot move.
 - Check positioning of the exhaust piping, resonator, muffler(s), and tips(s). Reposition if needed by loosening hardware, adjust position and retighten hardware.
 - When placement is confirmed, tighten all hardware to recommend torque spec.
 - Plug in the electrical harness to the exhaust valve
 - Thoroughly wipe down the exhaust system from any grease, dirt, handprints, fingerprints, etc... as these may cause a permanent stain once the exhaust reaches operating temp.
 - Reconnect the negative terminal of the battery
 - Start the engine. NOTE: Toyota has programmed the exhaust valve to be open at start up, and while stationary.
 - Check for any leaks, fitment issues, rubbing, etc..
 - Re-check for exhaust leaks, fitment issues, and re-torque all hardware after ~100 miles of driving.
- **We highly recommend that the all system components be inspected, and ALL hardware retightened at normal service intervals. Every 3000-5000 miles.**



WARRANTY POLICY

- 1-year limited manufacturer defect warranty from date of purchase
- All warranty claims are subject to inspection by REMARK at our facility
- Limited Warranty only applies to the original purchaser of the product
- REMARK is not responsible for fitment issues on non-US spec vehicles as all products are developed on US spec models
- Product finishes are not covered under warranty and considered wear & tear
- No warranty whatsoever will be valid if the defect was caused by abuse, negligence and/or mishandling. That includes weather conditions, natural disasters, any road/off-road conditions, and any accident/collision you were part of.
- Acidic cleaning products or steel wool are not to be used unless by a trained professional. Some chemical cleaning products may damage the product and/or finishes.
- Wear and tear (the damage that happens to our product in ordinary use) is not covered by our limited warranty.
- Improper installation or misuse of the product may lead to failure and damage to both product and vehicle. The user assumes all responsibility.
- All products are for use off-public streets and highways. Vehicle manufacturer warranty may be voided should any modification(s) or removal(s) of OEM(factory) components are determined.
- Federal and state law may prohibit the removal, modification or rendering of any device affecting vehicle emissions or state regulated decibel limits. It is the customer's responsibility to be aware of federal, state and local laws.
- User assumes all cost and risks associated with purchase and installation of aftermarket components. REMARK is not responsible for any fees, fines, or any type of penalties you have received from any authority.
- Buyers are responsible for all return shipping fees unless otherwise noted
- REMARK does not cover any installation, un-installation, labor fees, or related