

PRODUCT INFORMATION



MANUFACTURER: HONDA
YEAR: 2023+
MODEL: CIVIC TYPE R
TRIM: -
CHASSIS CODE: FL5
REMARK PART #: RK-C2076H-09TS
DESCRIPTION: CATBACK CONFIG. SUS304 FRONT OVERPIPE / TITANIUM RESONATED MIDPIPE & MUFFLER

PARTS LIST

No.	Description	Part Num.	Qty	Torque
1	3" Composite 3-bolt Gasket	76C3-H07	1	
2	3" Composite 3-bolt Gasket	76C3-H06	1	
3	3" Composite 2-Bolt Gasket	76C2-01	2	
4	M10 Serrated Hex Head Bolt L=40mm	M10B35	10	~42 ft-lbs.
5	M10 Serrated Nut	M10N	10	~42 ft-lbs.
A	3" Front Over Pipe	N/A	1	
B	Front Resonated Mid-pipe	N/A	1	
C	Rear Mid-Pipe	N/A	1	
D	Rear Muffler Section	N/A	1	

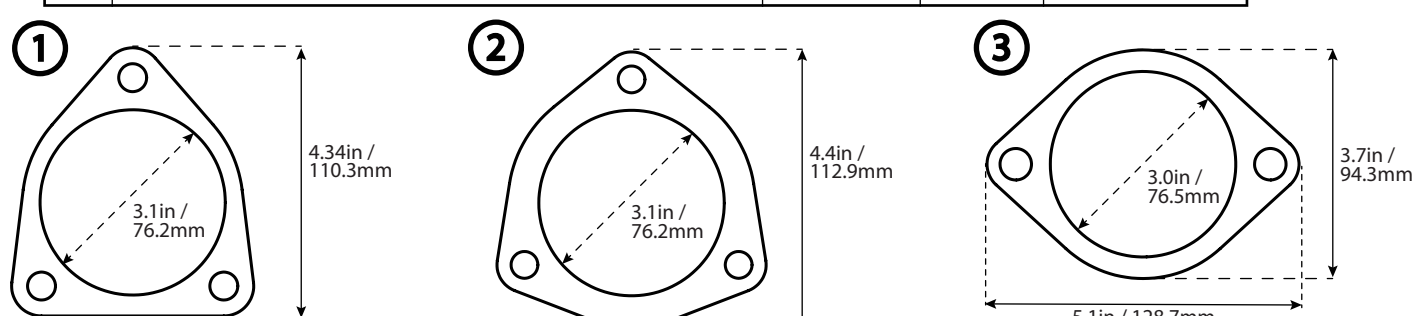

PARTS LAYOUT

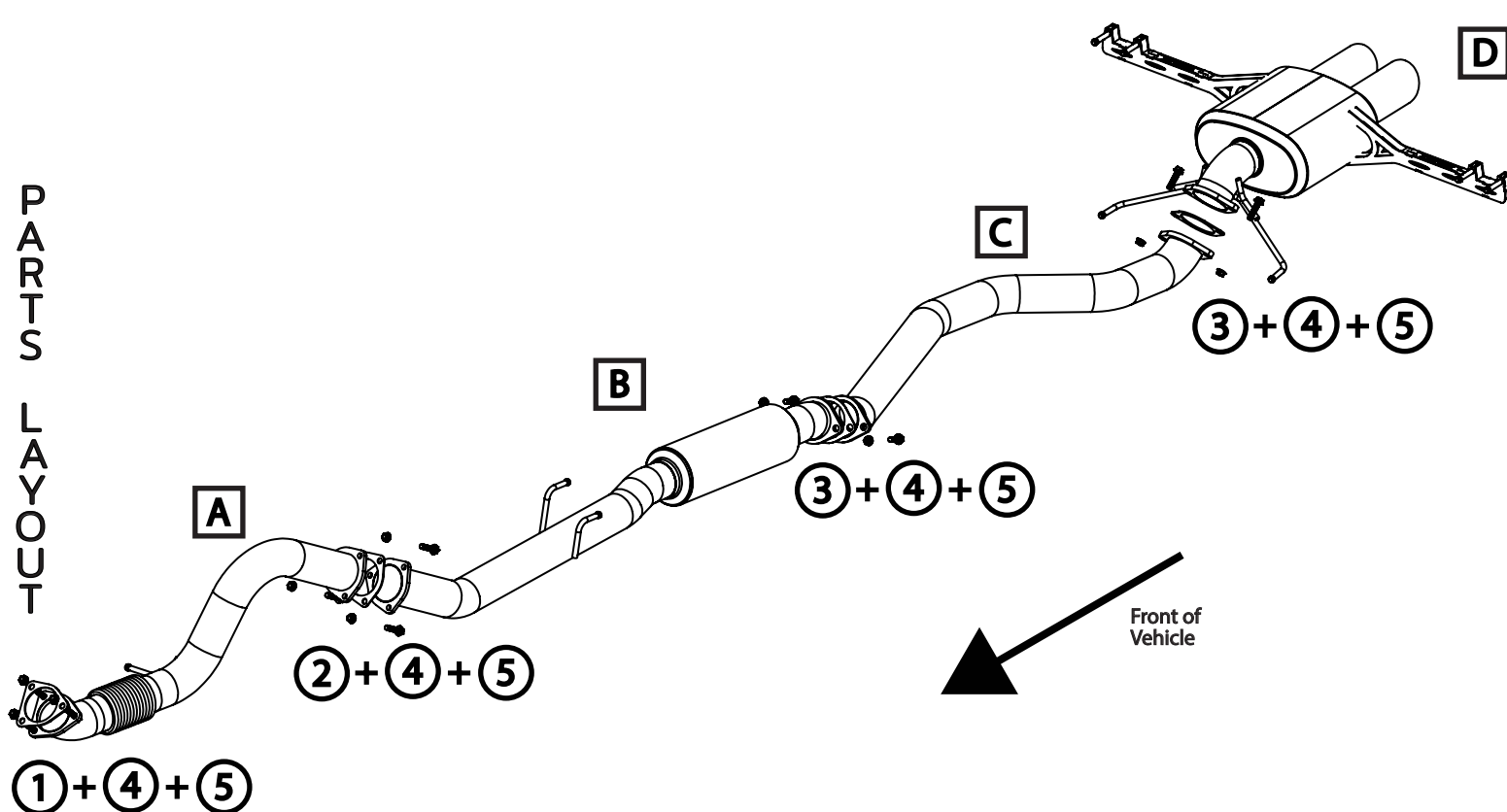

INSTALLATION

- We recommend installation to be performed by a trained and/ or qualified technician.
- Unplug the harness from OE exhaust valve motor and zip tie the harness up, out of the way
**NO CEL or any type of malfunction will be triggered by disconnecting the exhaust valve motor
- Remove the front lower splash shield to gain access to the front overpipe
- Remove OEM exhaust and or exhaust components include the front overpipe
- Install REMARK exhaust components using the original rubber hangers unless otherwise noted.
- We recommend starting from the front first and working your way rearwards.
- Install all gaskets and hardware. Leave the hardware hand tight.
- Align flanges, gasket, and snug all hardware so that sections cannot move.
- Check positioning of the exhaust piping, resonator, muffler(s), and tips(s). Reposition if needed by loosening hardware, adjust position and retighten hardware.
- When placement is confirmed, tighten all hardware to recommend torque spec.
- Gently shake/ move the exhaust system to ensure there is proper clearance around the entire system, especially the tips to bumper.
- Thoroughly wipe down the exhaust system from any grease, dirt, handprints, fingerprints, etc... as these may cause a permanent stain once the exhaust reaches operating temp.
- Re-install the front lower splash shield
- Start the engine
- Check for any leaks, fitment issues, rubbing, etc..
- Re-check for exhaust leaks, fitment issues, and re-torque all hardware after ~100 miles of driving.
** We highly recommend that the all system components be inspected, and ALL hardware retightened at normal service intervals. Every 3000-5000 miles. **



WARRANTY POLICY

- 1-year limited manufacturer defect warranty from date of purchase
- All warranty claims are subject to inspection by REMARK at our facility
- Limited Warranty only applies to the original purchaser of the product
- REMARK is not responsible for fitment issues on non-US spec vehicles as all products are developed on US spec models
- Product finishes are not covered under warranty and considered wear & tear
- No warranty whatsoever will be valid if the defect was caused by abuse, negligence and/or mishandling. That includes weather conditions, natural disasters, any road/off-road conditions, and any accidents/collision you were part of.
- Acidic cleaning products or steel wool are not to be used unless by a trained professional. Some chemical cleaning products may damage the product and/or finishes.
- Wear and tear (the damage that happens to our product in ordinary use) is not covered by our limited warranty.
- Improper installation or misuse of the product may lead to failure and damage to both product and vehicle. The user assumes all responsibility.
- All products are intended for use off-public streets and highways. Vehicle manufacturer warranty may be voided should any modification(s) or removal(s) of OEM(factory) components are determined.
- Federal and state law may prohibit the removal, modification or rendering of any device affecting vehicle emissions or state regulated decibel limits. It is the customer's responsibility to be aware of federal, state and local laws.
- User assumes all cost and risks associated with purchase and installation of aftermarket components. REMARK is not responsible for any fees, fines, or any type of penalties you have received from any authority.
- Buyers are responsible for all return shipping fees unless otherwise noted
- REMARK does not cover any installation, un-installation, labor fees, or related