

PRODUCT INFORMATION



MANUFACTURER: SUBARU
 YEAR: 2015 - 2021
 MODEL: WRX / STI
 TRIM: -
 CHASSIS CODE: VA
 REMARK PART #: RK-C1076S-01 : R1 SPEC. CATBACK, STAINLESS STEEL MUFFLER
 RK-C1076S-01T : R1 SPEC. CATBACK, TITANIUM MUFFLER

PARTS LIST

No.	Description	Part Num.	Qty	Torque
1	3" Composite 2-Bolt Gasket	76C2-T03	1	
2	3" Metal 2-Bolt Gasket	76C2-01	1	
3	M10 Serrated Hex Head Bolt L=35mm	M10B35	2	~42 ft-lbs.
4	M10 Serrated Nut	M10N	2	~42 ft-lbs.
5	M8 Serrated Hex Head Bolt L=35	M8B35	2	~25 ft-lbs.
6	M8 Serrated Nut	M8N	2	~25 ft-lbs.
7	3" Piping Clamp	N/A	1	~8 ft-lbs
A	Stainless Steel Front Midpipe Section	N/A	1	
B	Stainless Steel Rear Midpipe Section	N/A	1	
C	Muffler Canister (Stainless or Ti, depends on part num.)	N/A	1	
D	Muffler Canister Hanger, Long Hanger	N/A	1	
E	Muffler Canister Hanger, Short Hanger	N/A	1	

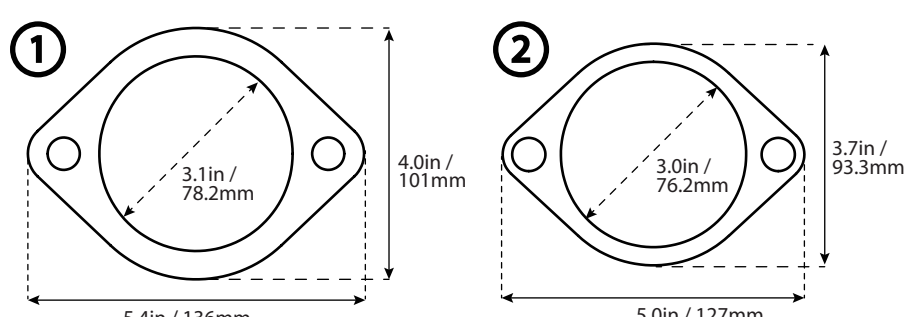

PARTS LAYOUT

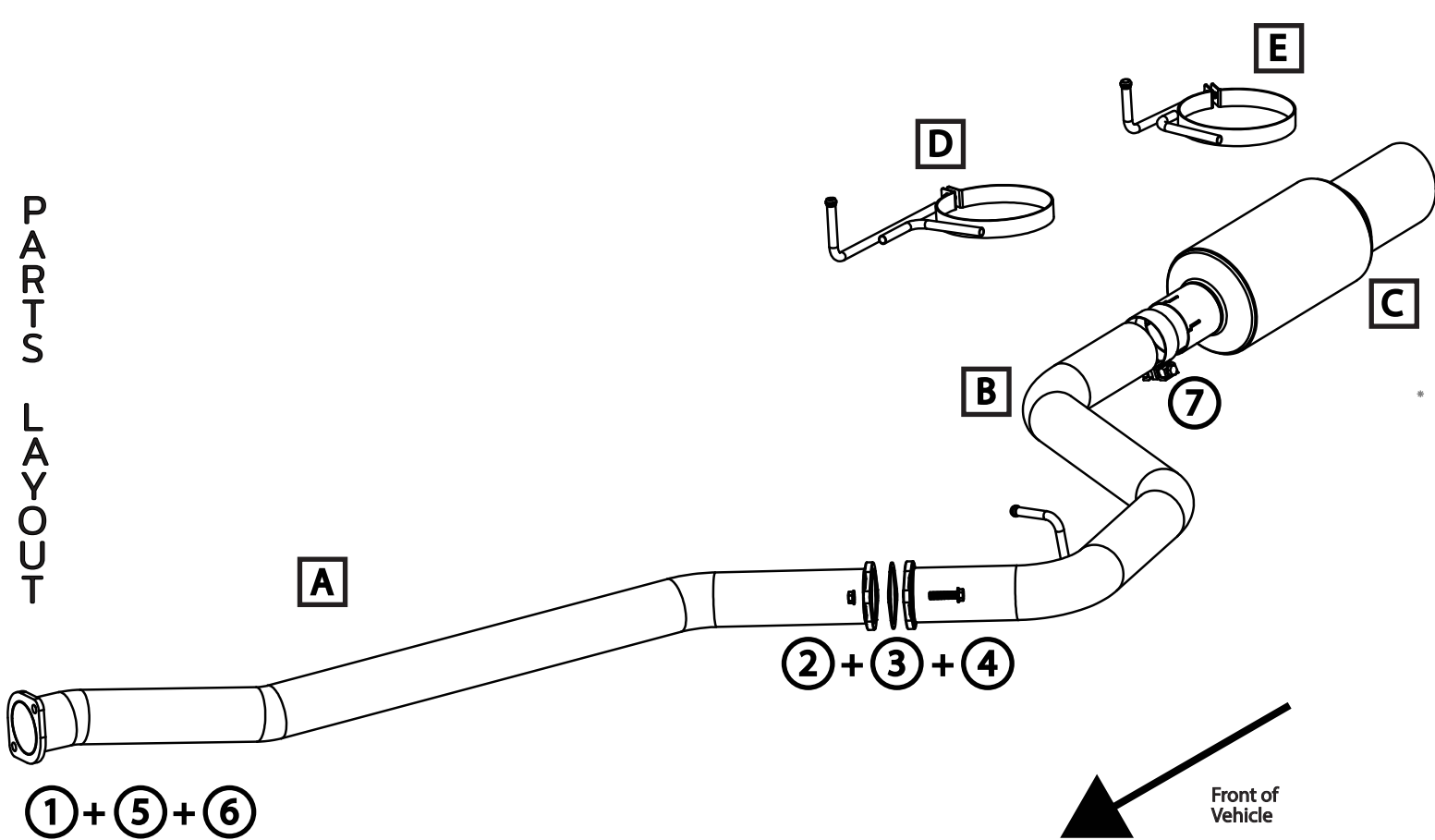

INSTALLATION

- We recommend installation to be performed by a trained and/ or qualified technician.
- Remove OE exhaust system: rear mufflers and midpipe.
- Remove OEM donut style gasket from downpipe (downpipe to midpipe connection). No adapter is needed.
- Install REMARK exhaust components using the original rubber hangers unless otherwise noted.
- Install all gaskets and hardware. Leave the hardware hand tight.
- Slip on the muffler hanger brackets [D] and [E].
 - [D] - Longer Hanger Rod - installed at the rearward section of the muffler canister with the rod tip facing front of vehicle
 - [E] - Shorter Hanger Rod - installed closer to the tip of the muffler canister with the rod tip facing the same direction as the muffler tip



- Align flanges, gasket, and snug all hardware so that sections cannot move.
- Check positioning of the exhaust piping, and tips(s). Reposition if needed by loosening hardware, adjust position and retighten hardware.
- When placement is confirmed, tighten all hardware to recommend torque spec.
- Gently shake/ move the exhaust system to ensure there is proper clearance around the entire system, especially the tips to bumper.
- Thoroughly wipe down the exhaust system from any grease, dirt, handprints, fingerprints, etc... as these may cause a permanent stain once the exhaust reaches operating temp. NOTE: If optioned with the Burnt finish tips, make sure to only clean with car wash soap and water. Some cleaners may affect the Burnt finish.
- Start the engine
- Check for any leaks, fitment issues, rubbing, etc..
- Complete one heat cycle of the exhaust system and re-tighten clamp [7].
- After ~100 miles of driving, re-check for exhaust leaks, fitment issues, and re-torque all hardware.



WARRANTY POLICY

- 1-year limited manufacturer defect warranty from date of purchase
- All warranty claims are subject to inspection by REMARK at our facility
- Limited Warranty only applies to the original purchaser of the product
- REMARK is not responsible for fitment issues on non-US spec vehicles as all products are developed on US spec models
- Product finishes are not covered under warranty and considered wear & tear
- No warranty whatsoever will be valid if the defect was caused by abuse, negligence and/or mishandling. That includes weather conditions, natural disasters, any road/off-road conditions, and any accidents/collision you were part of.
- Acidic cleaning products or steel wool are not to be used unless by a trained professional. Some chemical cleaning products may damage the product and/or finishes.
- Wear and tear (the damage that happens to our product in ordinary use) is not covered by our limited warranty.
- Improper installation or misuse of the product may lead to failure and damage to both product and vehicle. The user assumes all responsibility.
- All products are intended for use off-public streets and highways. Vehicle manufacturer warranty may be voided should any modification(s) or removal(s) of OEM(factory) components are determined.
- Federal and state law may prohibit the removal, modification or rendering of any device affecting vehicle emissions or state regulated decibel limits. It is the customer's responsibility to be aware of federal, state and local laws.
- User assumes all cost and risks associated with purchase and installation of aftermarket components. REMARK is not responsible for any fees, fines, or any type of penalties you have received from any authority.
- Buyers are responsible for all return shipping fees unless otherwise noted
- REMARK does not cover any installation, un-installation, labor fees, or related