

Single Press Wheel **Instruction Manual**



Parts Included

1 x Single Press Wheel Includes:

1 x Wheel

1 x Main Frame

1 x Axle

2 x M12 50 x 80 U-Bolt

1 x M24 Nyloc Nut

4 x M12 Nyloc Nut

2 x Spacer

Step 1:

Put the axle through the hole and lay the main frame down.

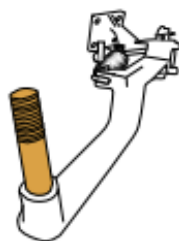

Step 2:

Take one bushing and place it over the axle.

*Tip: You can put anti seize inside the spacer to prevent it from rusting onto the axle.

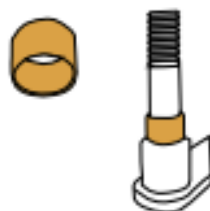

Step 3:

Place the wheel onto the axle and then put the remaining spacer on.

Step 4:

Fasten on the M24 nyloc nut and tighten.

Do Not Over Tighten.

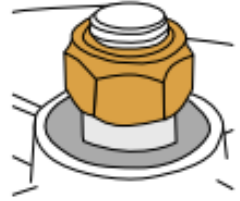

Step 5:

Bolt your single press wheel to your bar using the U-bolts provided

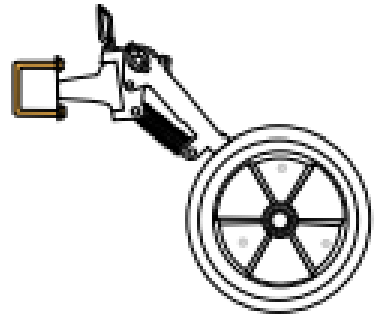

We recommend
1 x vertical/extension bar
set per 5 press wheels

*Recommendation
only. Some seeding
bars require different
configurations.

BAR
EXTENSION

VERTICAL
BAR

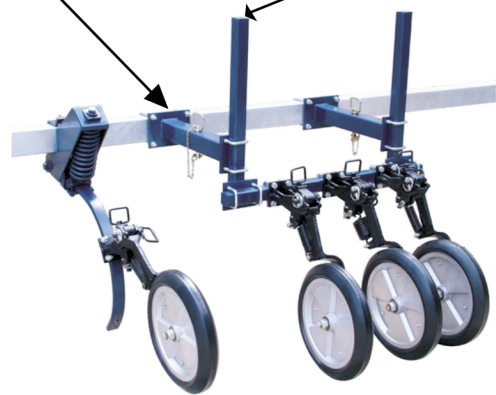

If you have any questions about installing your Single Press Wheel please do not hesitate to give us a call on **08 9354 1111**

Reorder Part No.

Wheel	SP-1100
M12 50 x 80 U-Bolt	FA-0702
M24 Nyloc Nut	FA-0406
M12 Nyloc Nut	FA-0403
Spacers	FA-0871

We love seeing our products ready for action!

Text a photo to **0499 225 219**
along with your name and
postage address and we will
send you a FREE Maxipoint hot
sauce!

