

Yamaha G14/16/19 Rear Flip Seat Kit

instruction manual

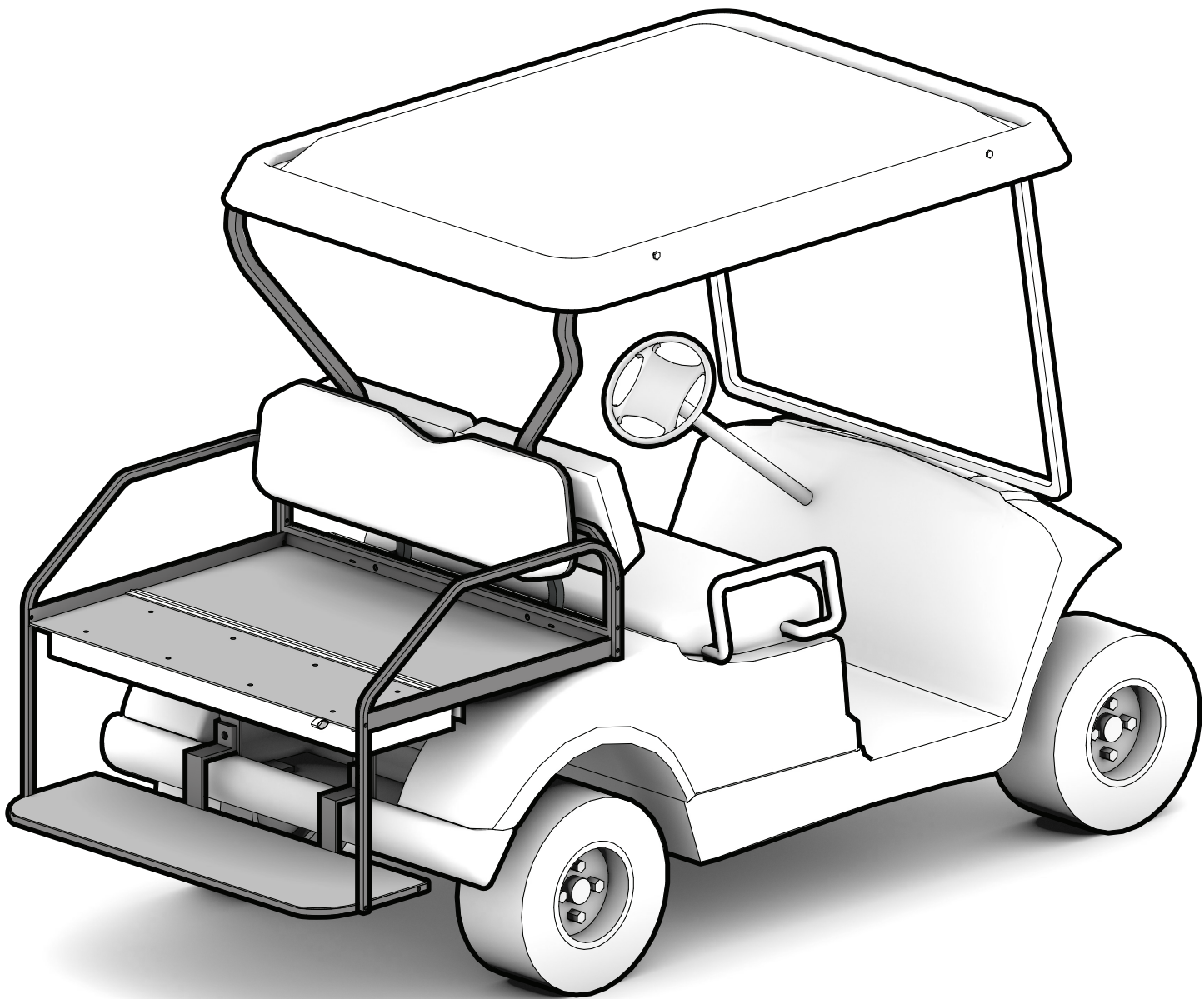

Parts List

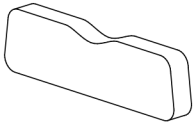

Back Pad (1)

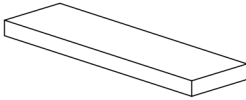

Seat Pad (1)

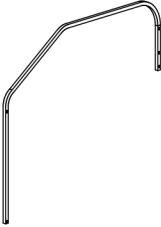

Side Frame (2)

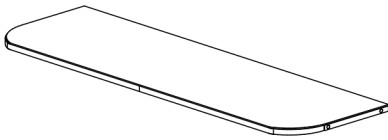

Step Plate (1)

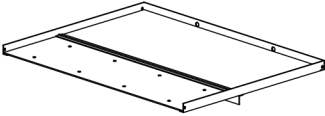

Flip Seat Frame (1)

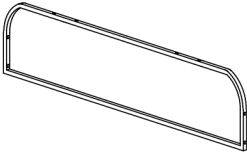

Back Frame (1)

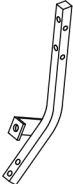

Front Supports(2)



Roof Supports(2)

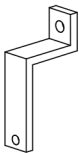

Step Plate Supports(2)

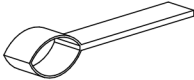

Seat Pull(1)

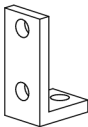

Rear Seat Supports(2)

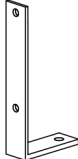

Rear Supports(2)

*Parts not shown in proportion.

Bolts - **actual size**

Allen Bolt 1"
(8)



1/4" x 1"
(4)



1/4" x 1 3/4"
(2)



5/16" x 1"
(6)



5/16" x 1 1/2"
(4)



5/16" x 2"
(4)



5/16" x 2 1/2"
(6)



1/4" Washer
(8)



5/16" Washer
(40)

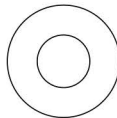

1/4" Nyloc Nut
(2)



5/16" Nyloc Nut
(18)

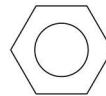

5/16" Acorn Nut
(2)



Installation

1. Remove roof supports and cushions.

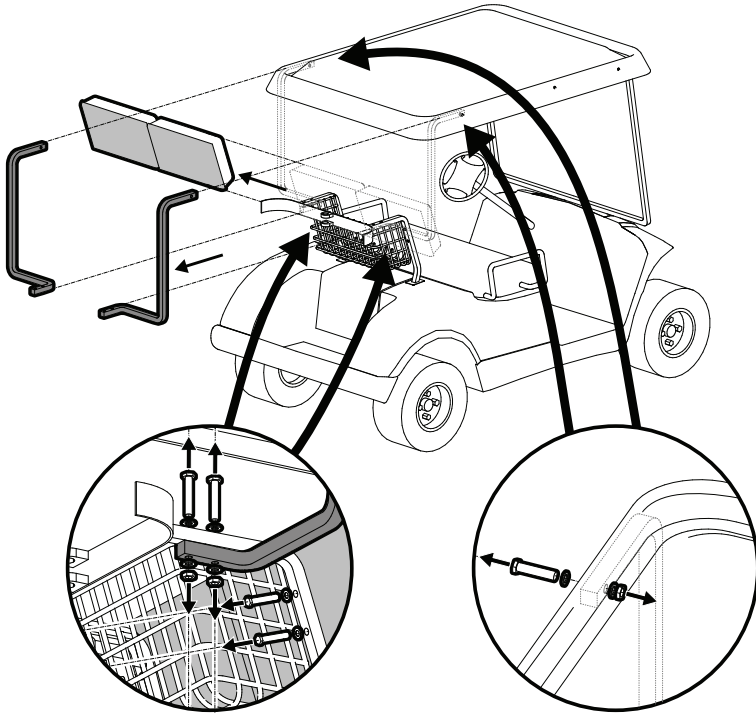

Remove bolts connecting roof supports and seat cushions to bag supports.

Remove bolts connecting roof supports to roof.

2. Remove access panel and bag supports.

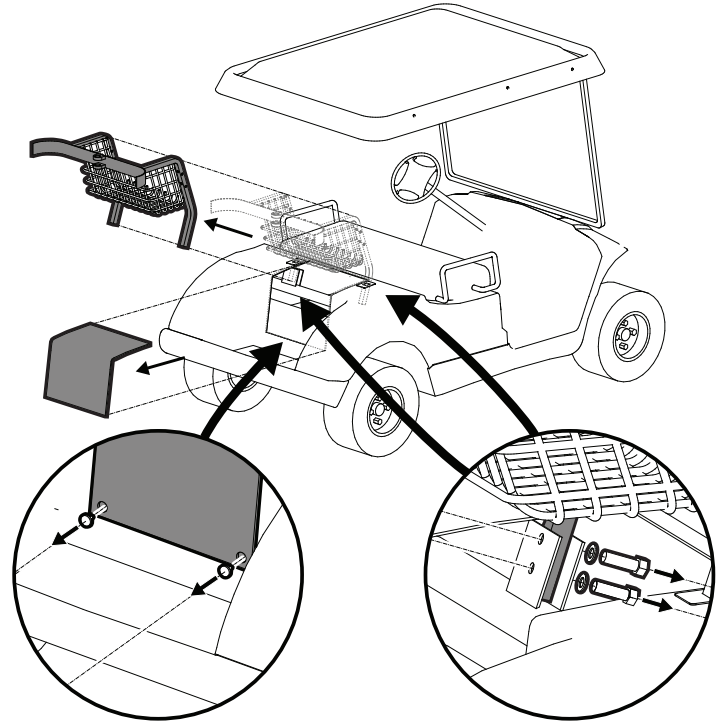

Remove screws connecting access panel to body.

Remove bolts connecting bag supports to rear frame bar.

3. Install frame supports and access panel.

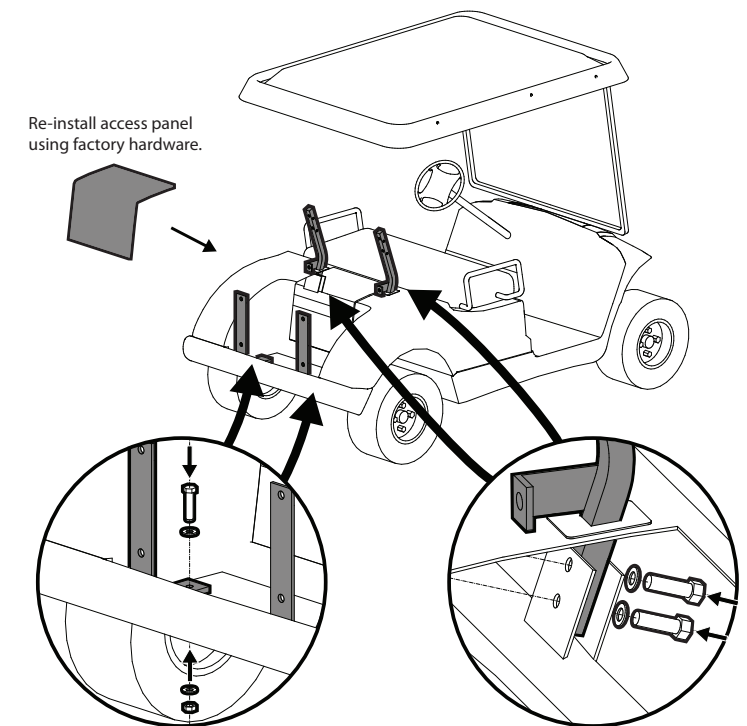

Re-install access panel using factory hardware.

Remove existing bolts in bagwell and drill holes to 3/8". Bolt rear frame supports to bag well using 5/16" x 2" bolts, flat washers, and nuts.

Bolt front supports to rear frame bar using factory hardware.

4. Install seat frame.

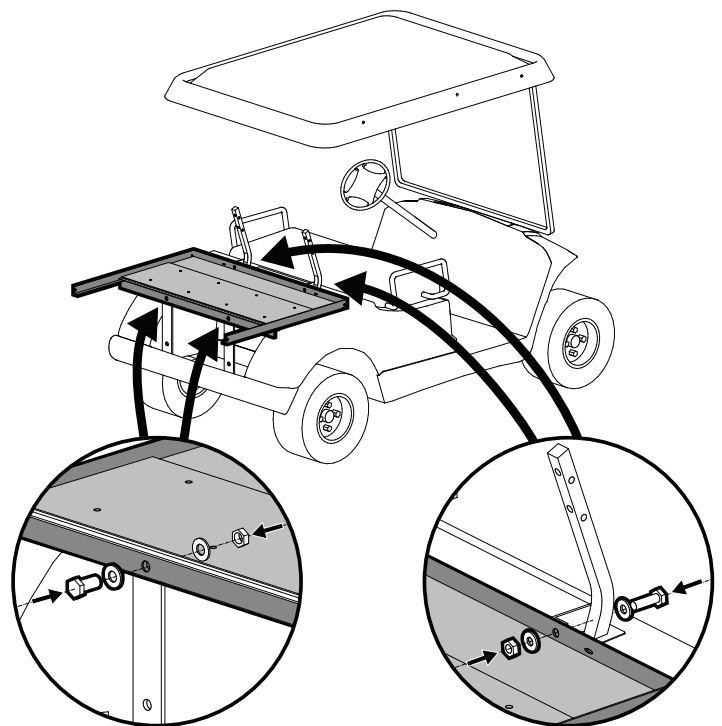

Bolt rear supports to underside of flip seat frame with 5/16" x 1" bolts, flat washers, and nuts.

Bolt front supports to outer side of flip seat frame with 5/16" x 1" bolts, flat washers, and nuts.

Parts not shown in proportion.

Installation

5. Install side rails.

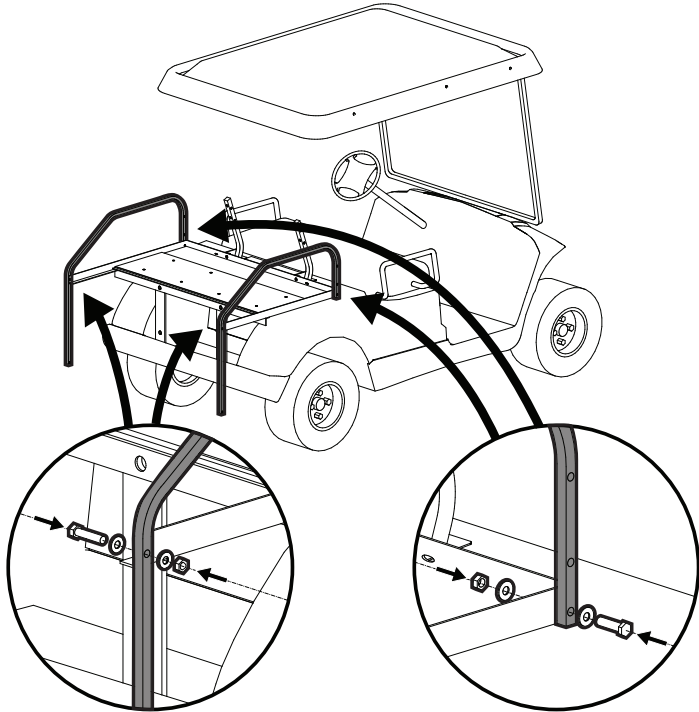

Bolt side rails to rear of flip seat frame with 5/16" x 1 1/2" bolts, flat washers, and acorn nuts.

Bolt side rails to front of flip seat frame with 5/16" x 1 1/2" bolts, flat washers, and nyloc nuts.

6. Install back frame.

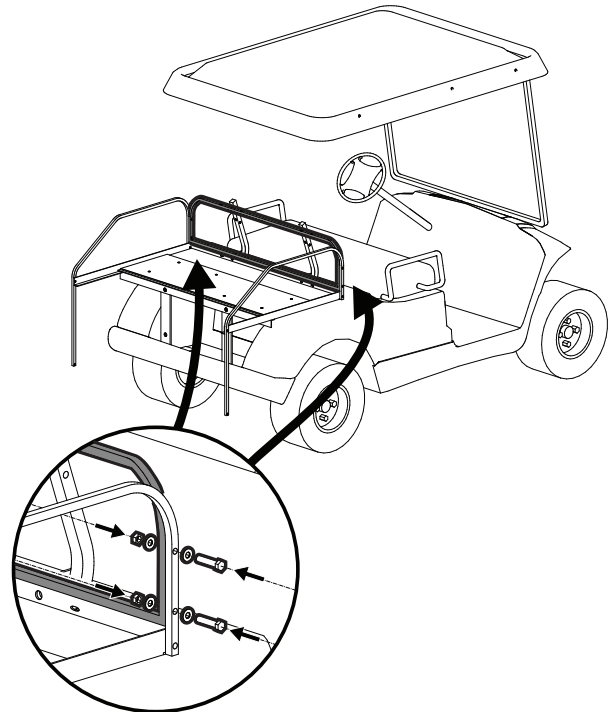

Bolt back frame to side rails with 5/16" x 2 1/2" bolts, flat washers, and nuts.

7. Install step plate.

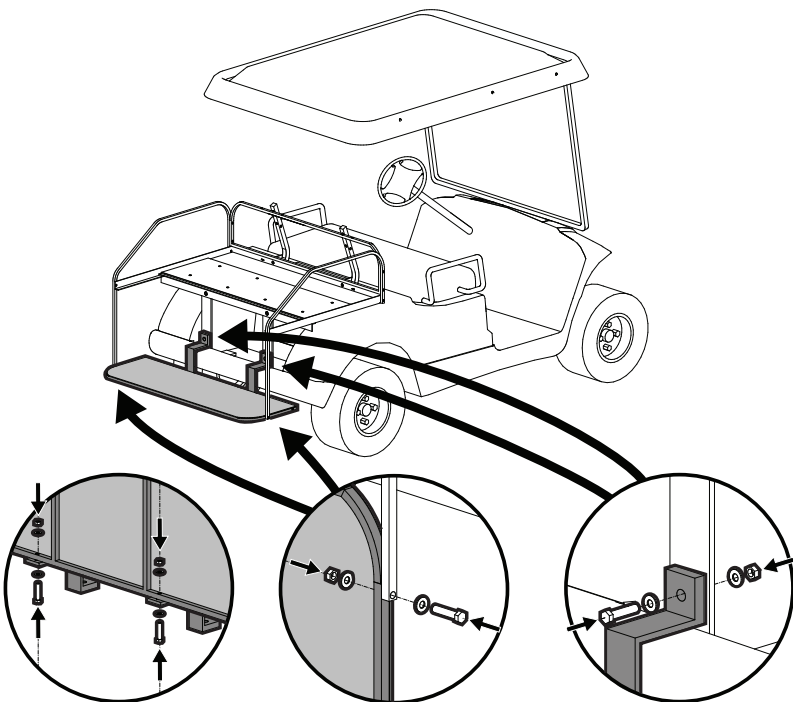

Bolt step supports to step plate with 5/16" x 2" bolts, flat washers, and nyloc nuts.

Bolt step plate to side frames with 5/16" x 2 1/2" bolts, flat washers, and nyloc nuts.

Bolt step plate to rear supports with 5/16" x 1" bolts, flat washers, and nyloc nuts.

8. Re-install roof supports and front cushions.

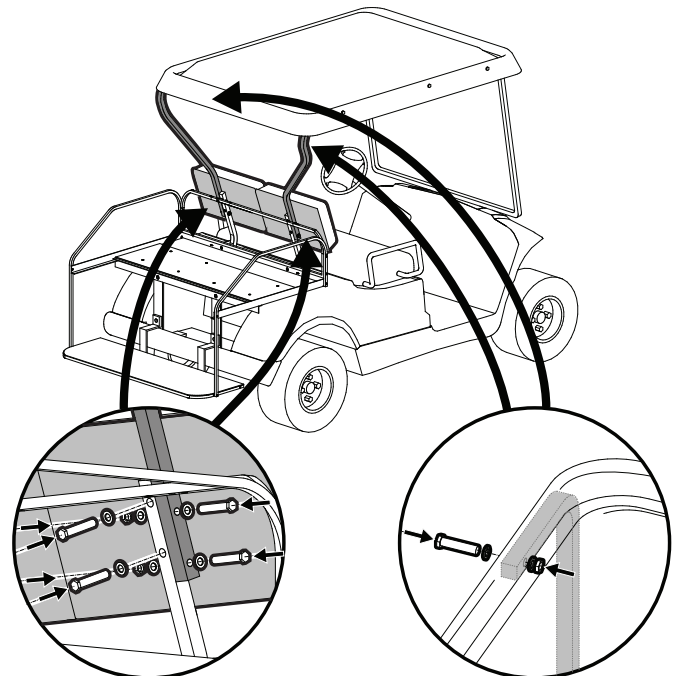

Bolt roof supports and seat cushions to front supports using factory hardware.

Bolt roof supports to roof using factory hardware.

Installation

9. Install rear seat back pad.

10. Install flip-seat pad.

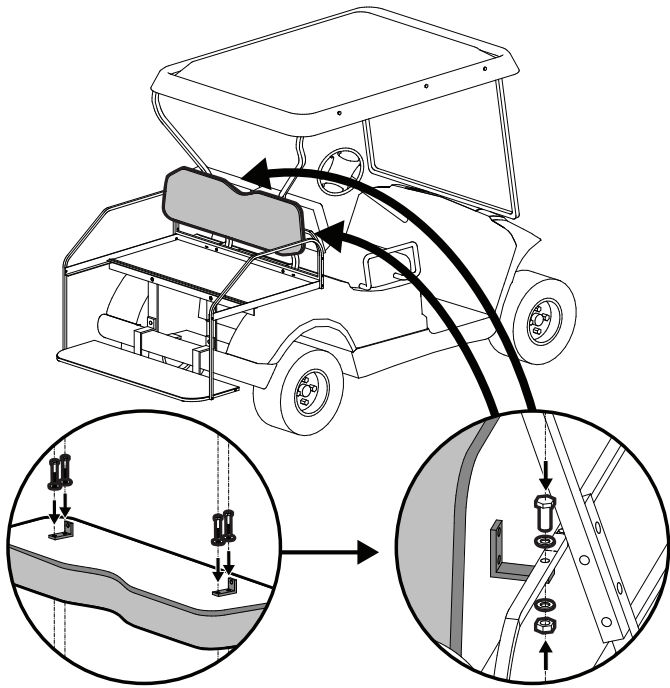

Bolt rear seat supports to back of rear seat back pad using 1/4" x 1" bolts and flat washers.

bolt rear seat back pad to back frame using 1/4" x 1 3/4" bolts, flat washers, and nuts.

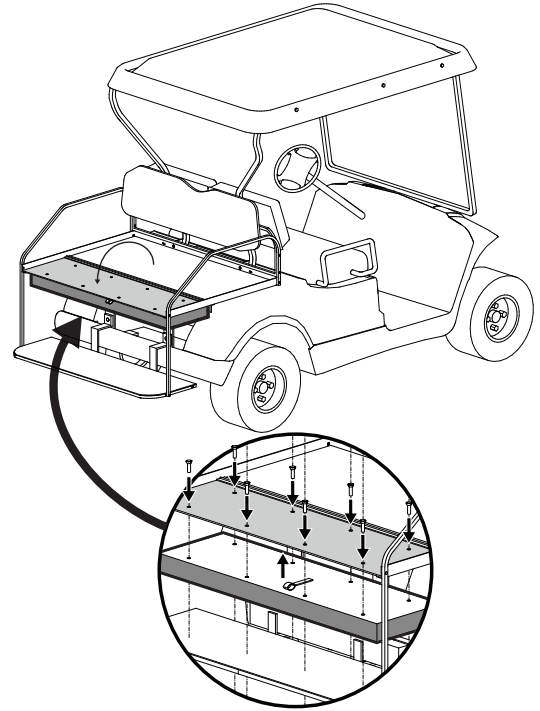

Attach flip seat pad to underside of cargo panel with allen bolts(8). Secure seat pull in between pad and panel.