

Drive-Alert

Vehicle Detection Systems



Model DA-500 Installation & Operations Manual

General Information

Drive-Alerts are perfect for use in residential driveways, on farms, at drive-up windows, in remote locations, and to protect valuable equipment such as tractors or construction vehicles. The Drive-Alert will detect a vehicle approaching, or whenever a vehicle or metal equipment is moved.

The Drive-Alert detects any metal which contains iron. It will not detect copper or aluminum.

The Drive-Alert's method of operation is to sense the change in the magnetic field around it. This field is always present, and is disrupted when a metal object moves through it. The key element in the Drive-Alert installation is to locate the sensor/probe in the area where you wish to detect this change. The usual installation is near the entrance of a driveway, but located far enough away from roads or streets so as not to detect traffic.

Moving ferrous (iron) metal trips the sensor. Larger metal objects are detected easier than smaller. Faster moving metal objects are detected easier than slower. Metal moving nearer the probe is detected easier than metal moving farther away. These are the three factors which determine the system's range of detection. Therefore, trucks traveling 65 mph can be detected up to 50 feet; cars moving 4 mph up to 8 feet; and a walking person with steel toe shoes up to 1 foot.

The Master Control Panel houses the electronics which allows the Drive-Alert to function. It also contains a noisemaker, and the terminal strip permits the attachment of the probe as well as remote noisemakers or other devices.

A Timer Control unit is available. It is housed in a separate box and is attached by wires to the terminal strip on the Master Control Panel. The Timer Control turns on of lights, usually outside lights, for an adjustable period when a vehicle is detected.



DA-500 Complete
includes a Master Control Panel,
Sensor, and 100' of direct
burial cable



DA-655 Chime with Volume



DA-505 Timer Control



DA-052 Remote Whistle

INSTALLATION

The Master Control Panel is generally located in a closet, utility room, or garage. If the only noisemaker used (remotes are available) is the one contained within the control panel, the panel must be located where users can easily hear the “whistle.” The control panel is not suitable for outdoor installation. Also, 120 volt AC power must be available. The ease of routing the three-wire cable from the sensing probe should be considered when deciding the location of the panel. The control panel is usually attached to the wall with screws.

Improper installation is the No. 1 reason for system malfunction. Please use caution when installing the sensing probe to assure a properly operating Drive-Alert.

The probe’s sensor is a coil of wire wrapped around an iron rod. Its resistance is 900-1100 ohms. The red and black wires connect to the coil. It is encapsulated in epoxy to protect it from physical damage and moisture.

**DO NOT CUT OR NICK THE CABLE JACKET!
If moisture enters, false alarms will be the result!**

The cable is made with an extra thick outer cover. There is a foil wrapper surrounding the red and black wires. There is a silver (bare) wire in the foil. False alarms will occur if moisture gets into the foil wrapper. Nicks in the outer cover and improper splices allow moisture to enter the cable. As moisture enters the cable, the resistance decreases. Resistance between the red or black wire to the shield wire must be infinite. (Use meter with ability to read resistance above 20 million ohms).

The ideal installation is without any splices. The use of cable other than that which is designed for the Drive-Alert is undesirable. Improper splices and unsuitable cable are major causes of false alarms. If splicing is unavoidable, splice the cable using a 3M SLiC-TM SPLICE KIT, or equivalent. The splice kit is available from Mier Products.

The sensing probe does not know if it is in or out of the ground, but it must remain absolutely motionless. Most probes are buried 6 inches deep and parallel to the driveway. Be sure to protect it from physical damage.

The cable is made for direct burial in the ground. Do whatever is necessary to protect it from physical damage to the outer cover, such as using 1/2-inch PVC pipe.

The probe responds to changes in the magnetic field around it. The signal produced by the coil is a few micro volts for a fraction of a second. The probe and cable must not be within 3 feet of electric wires because they have changing magnetic fields of their own. Never bury the cable in the same trench with other electrical wires, including telephone wires and wires for lights, bells, etc.

You may wish to place a sensing probe atop the ground in the general area of where you wish to bury it, and connect the cable to the control panel. This will allow you to TEST the system in application BEFORE final installation. It would be acceptable to leave the sensing probe and cable above the ground for a couple of days, but make certain it is not damaged during this period. This method should not be used permanently. See OPERATIONS INSTRUCTIONS for adjustments which may be necessary.

The burial of the probe is ideal in the center of the area being monitored, but often is not practical. If a new driveway is being put in, the sensing probe could be buried a minimum of 12-24 inches deep. In case you wish to place the sensor in the center of the drive, the cable and sensing probe could be placed in a larger piece of PVC to provide protection. The cable should also be protected whenever vehicles move over it.

The usual installation of the sensing probe is parallel to an already existing driveway. In this case, the probe can be buried 6 inches deep, and the cable simply placed below the grass line. However, if vehicles are going to travel directly over the probe and cable, they should be buried deeper.

The sensing probe may be placed up to 5,000 feet from the Master Control Panel. Up to 4 sensing probes can be attached to one panel, but each additional probe reduces every probe’s ability to detect. The Drive-Alert will not know which sensing probe detects a vehicle.

When more than 1 probe is used, connect the red and black wires in series. Connect the silver wires in parallel. The red wire from one cable is soldered to a black wire from another cable. The remaining red wire & black wire are attached to the Drive-Alert terminals. All silver wires are attached to the Drive-Alert.

Keep the probe, cable, and control panel at least 8 feet away from heavy power lines, power panels, motors, arcing or sparking machinery, and radio transmitters. In some cases, moving the panel and/or cable a few feet can solve interference problems.

OPERATION INSTRUCTIONS

The Drive-Alert is adjusted at the factory for maximum sensitivity for the probe and minimum time for the whistle. To adjust these, open the control panel and adjust the small pots according to the diagram on the inside cover (see below). The whistle "timer adjust" is adjustable from 1-12 seconds and the LED 3 will light.

When first plugged in, the red blanker LED 2 will remain on for only 1 minute, and the Drive-Alert will be muted for approximately 1 minute each time the electrical power is turned on. It provides time for the electronic circuits to stabilize.

During normal operation, the noise blanker detects unwanted electrical interference and mutes the Drive-Alert for a few seconds. It has been adjusted at the factory. The blanker light should be off during normal operation.

To test the Master Control Panel, it is possible to rub your finger simultaneously on the three terminals to which the sensing probe is attached. This should cause the system to go into false alarm. This will occur with or without the sensing probe attached. Be sure the terminal screws are tight while making the test. If the system responds to this test, in almost all instances it indicates a properly functioning control panel.

If false alarms occur, remove the sensing probe wires from the Drive-Alert terminals. Let the power remain turned on to the control panel. If the false alarm stops, then the most likely cause of the problem is moisture in the sensing probe cable. Radio transmitters, cell phones, and cordless phones within 10 feet of the control panel may cause false alarms. Please call for special filter instructions in these cases.

Additional devices can be attached to the Drive-Alert on its terminals at the bottom of the control panel. When the whistle switch is turned off, the Drive-Alert terminals can switch customer provided electrical current up to 5 AMPS. Never attach any device that puts more than 30 volts on the Drive-Alert terminals. When the whistle switch is turned on, the Drive-Alert terminals have available 24 VDC at 100 MA. Refer to the diagrams in this manual for hookup instructions.

Mier Products has available a Timer Control that attaches to the Drive-Alert terminals. The Timer Control is adjustable from 45 seconds to 45 minutes. It switches up to one thousand watts of 115 volt power for outside lights. Mier Products also has available remote chimes (the DA-655 is the most popular accessory and perfect for drive-up window applications), whistles, and other devices.

MASTER CONTROL PANEL ADJUSTMENTS

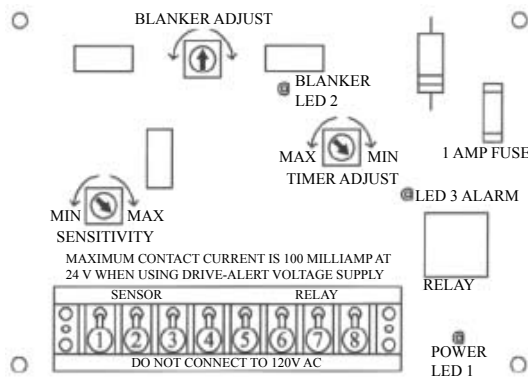

CONTROLLING EXTERNAL ALARMS & CHIMES

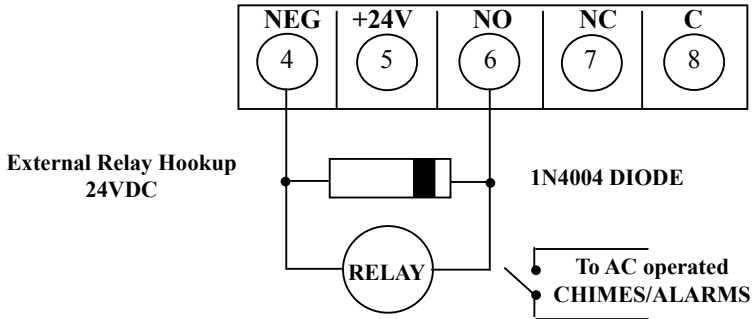
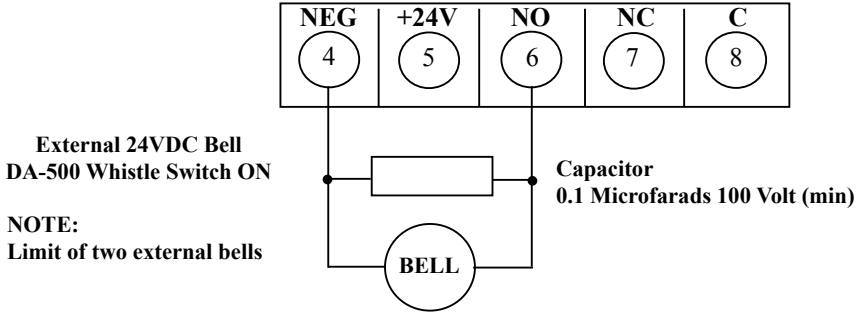

NOTE: If internal piezo whistle is not wanted, move the DA-500 Whistle Switch to the OFF position and connect the jumper between +24 and the C Terminal

CONNECTION USING DRY CONTACTS & EXTERNAL POWER

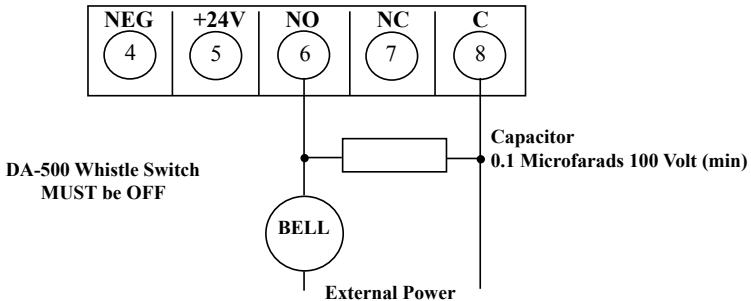

Maximum current limited to 1 AMPERE
Maximum Voltage - 24 VOLTS (**DO NOT** apply 120VAC to terminals)

RED	BLK	SHLD	NEG	+24V	NO	NC	C	
---				UNREG	---			
--- SENSOR ---				--- RELAY ---				
1	2	3	4	5	6	7	8	
DO NOT CONNECT TO 120V AC								

DA-500 Sensor and Remote DA-052 Whistle Connection

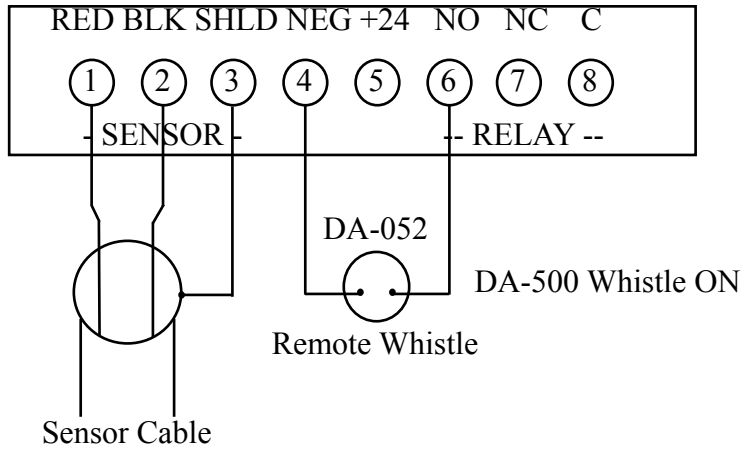

Note: Limit of 10 Whistles

Using AC house wiring for transmitting alarm signal

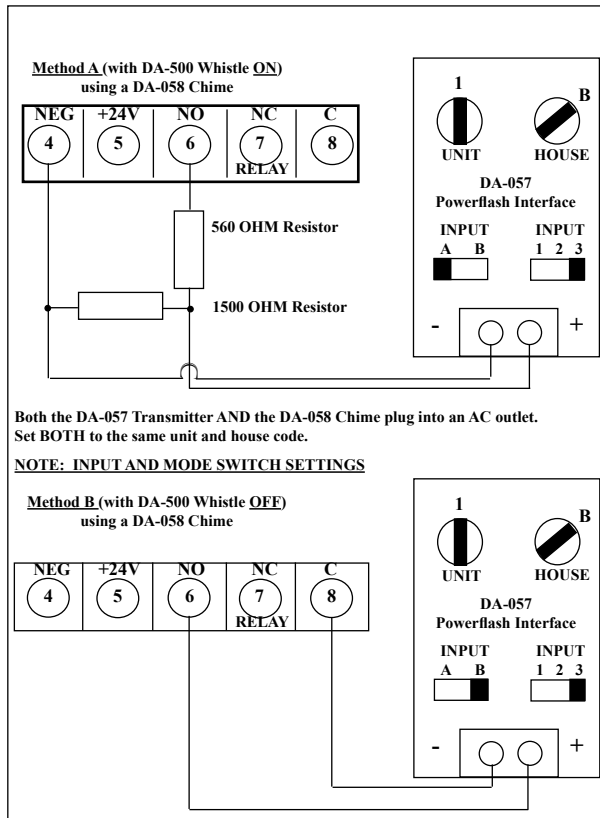

Model DA-500 Drive-Alert Contents

- Solid-state Master Control Panel
- Electronic whistle with “on-off” switch
- Red LED power-on indicator
- UL listed transformer and cord
- 100 feet of two-conductor shielded direct burial cable; other lengths available
- Weatherproof sensor
- SPDT relay output available

Specifications

- Input -- 120 VAC, 50-60Hz, 3.6 Watts
- Output -- 24 VDC at 100 Milliamps
- Surge protected from transients
- Adjustable sensor sensitivity
- Adjustable time control for electronic whistle
- Operating temperature -- 20 degree F to 160 degree F
- Provisions for activating optional timer control
- Weight -- six (6) pounds

Mier Products' Limited Warranty Program

The Mier Products' Limited Warranty Program covers only the Drive-Alert -- for original owner only -- for one year from date of purchase against defects in original parts or workmanship. It agrees to repair or replace such defects (Mier Products' option) -- without charge for parts or labor -- if the defective unit is returned prepaid to **Mier Products, Inc., Kokomo, IN, 46901, within the first year.** Sensor probe and cable that have been buried are not covered.

Responsibility is not assumed for damage due to accident, faulty wiring, overload of Drive-Alert output, or installation other than that recommended by Mier Products, Inc. Repair work not covered by the Warranty will be made at a nominal charge. When returning a unit for any reason, please include a note describing the problem. Also include your name, address and telephone number.

For Technical Assistance please call 1-800-473-0213



1500 North Ann Street, Kokomo, IN, 46901

www.mierproducts.com

info@mierproducts.com

800-473-0213

DA-655

Drive-Alert Chime with volume control

DA-655



- The DA-655 is the perfect accessory for the original DA-500 and the new DA-600 wireless Drive-Alerts when a more pleasant tone and/or volume control is desired.
- **Perfect for drive-up windows and high traffic areas**
- The DA-655 Chime replaces the whistle within the Drive-Alert, and emits a pleasant chime whenever a vehicle is detected.
- Volume can be adjusted from silent to a very loud setting
- Easy to install
- Connecting cables included

Call us! We'll be happy to help with any technical or installation questions...and don't forget to check out our website for more products!

Residential Driveway Application



Drive-Up Window Application



DA-600



Wireless DA-600 Complete Drive-Alert Driveway Alarm System is pictured above for reference.

DA-500



Original DA-500 Complete Drive-Alert Driveway Alarm System is pictured above for reference.



www.mierproducts.com

Drive-Alert

Vehicle Detection Systems

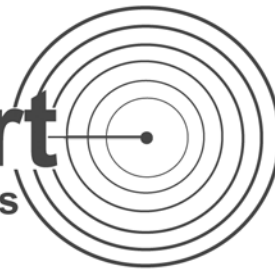

Buried Sensor Vehicle Detection Systems

For more information on these units, our wireless Drive-Alerts,
or our other products please visit
www.mierproducts.com

2009 DA-503 and DA-504 BURIED SENSOR DRIVE-ALERT INSTALLATION AND OPERATION MANUAL

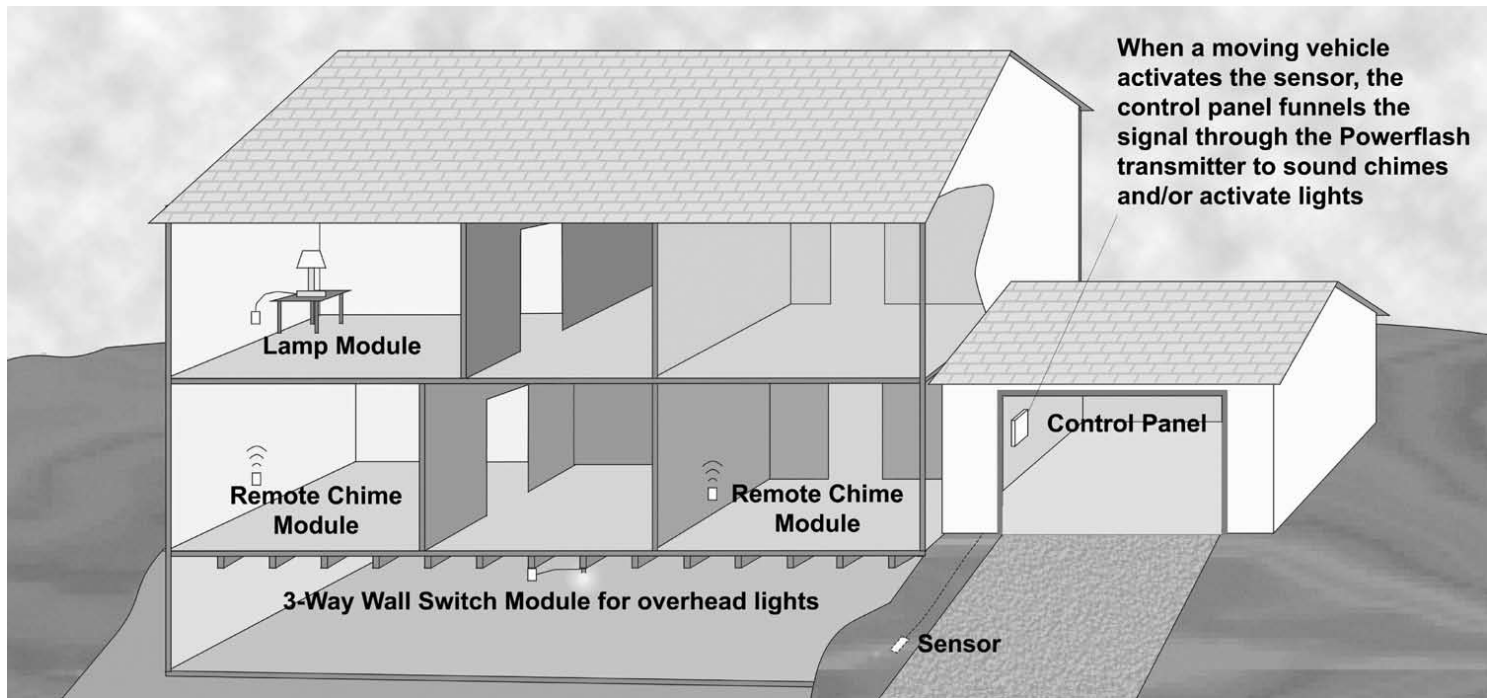

1-800-473-0213 | www.mierproducts.com

Wireless Vehicle Detection | Driveway Alarms | Drive-Up Window Detection | Buried Sensor Systems | Instrument Boxes
DVR/CPU Lockboxes | Flush-Mount Cabinets | Outdoor Enclosures | NEMA 4 Enclosures | Temperature Controlled Enclosures
Power Supply Boxes | Siren/Speaker Cabinets | Bell Boxes | Battery Cabinets | Transformer Enclosures | Custom Fabrication

Introduction

The installation of an alarm system that sounds an alert of an approaching vehicle has become easier with the DA-503 and DA-504 Drive-Alert Warning Systems. The DA-503 and DA-504 expand the Drive-Alert's usefulness by transmitting the alarm throughout a building without using wired connections. A building's electrical wiring is used to carry the signal where desired.

The DA-503 utilizes pleasant chimes to let you know of a vehicle's approach. The DA-504 expands this feature by including a timer feature to illuminate vehicle entrance areas for selected times using remotely controlled lamps. The Drive-Alert's most popular use is in driveway applications. A probe senses the earth's magnetic field and when a passing vehicle disturbs that field, an alarm is generated and transmitted to alert you of the vehicle's presence.

Locating the sensor probe adjacent to a driveway but away from street traffic allows the detection and warning of a vehicle entering a selected area. Fast moving vehicles, particularly trucks, along a street can be detected up to 50 feet from the sensor. Slow, moving cars traveling at 5 miles an hour can be detected 8 feet away, and a person walking with steel toed shoes up to 1 foot away also can be detected. Thus, a probe location should be chosen with the above in mind. The Master Control contains the detection and signaling electronics that sends the alarm to all parts of a building.

SPECIFICATIONS

Input - 120 VAC, 50-60 HZ, 3.6 Watts

Output - Power line carrier signaling

Auxiliary Output - 12 VDC at 100 Milliamps

Adjustable sensor sensitivity

Operating temperature is -30 degrees F to 120 degrees F

Weight - 6 pounds

Table of Contents

INTRODUCTION	Page 2
DRIVE-ALERT WARRANTY	Page 3
INSTALLATION OF SENSOR	Page 4-5
INSTALLATION OF DA-503	Page 6
INSTALLATION OF DA-504	Page 7-8
ACCESSORIES	Page 8
TROUBLE-SHOOTING HINTS	Page 9
EXPLANATION OF LEDS	Page 10



Drive-Alert Warranty

MIER PRODUCTS LIMITED WARRANTY PROGRAM

The Mier Products Limited Warranty program covers the Drive-Alert - for original owner only - for one year from date of purchase against defects in original parts or workmanship. Mier Products, Inc. agrees to repair or replace parts (Mier's option) that are deemed defective by our Quality Control Team, without charge for parts or labor, if the defective unit is returned prepaid to Mier Products, Inc., Kokomo, IN, 46901, within the one-year warranty period. Mier Products, Inc. recommends inspection of parts immediately upon receipt and contacting Mier Products, Inc. if quality issues arise.

Mier Products, Inc. does not assume responsibility for claims or damages caused by improper installation or use of these products, accessories, and/or products connected to them. Mier Products, Inc. does not assume responsibility for damages to these products or their accessories due to shipping damage or damage occurring while in a customer's warehouse and/or possession. These products and any accessories must be shipped, handled, stored, and installed with strict adherence to our instructions. Responsibility is not assumed for damage due to accident, faulty wiring, overload of Drive-Alert output, or installation other than that recommended by Mier Products, Inc. Repair work not covered by the Warranty will be made at a nominal charge. When returning a unit for any reason, please include a note describing the problem. Also include your name, address, and telephone number. Sensor probe and cable that have been buried are not covered by warranty.

This warranty constitutes the entire warranty with respect to Mier's Drive-Alert Systems and IS IN LIEU OF ALL OTHERS, EXPRESSED OR IMPLIED, INCLUDING ANY WARRANTY OR MERCHANTABILITY AND WARRANTY OF FITNESS FOR A PARTICULAR PURPOSE AND IN NO EVENT IS MIER PRODUCTS, INC., OR IT'S OEM PARTNERS, RESPONSIBLE FOR ANY CONSEQUENTIAL DAMAGES OF ANY NATURE WHATSOEVER.

Any warranty OR sales questions should be directed to Mier Products at 800-473-0213, or via e-mail to info@mierproducts.com



Installation of Sensor

Caution and care must be exercised in installing the sensing probe to assure a properly operating Drive-Alert System. Improper installation is the number one reason for the systems to malfunction. The probe's sensor is a coil of wire wrapped around an iron rod. Its resistance is 700 to 1200 ohms. The red and black wires connect to the coil. It is encapsulated in epoxy to protect it from physical damage.

The cable is made with an extra thick outer cover. There is a foil wrapper surrounding the red and black wires. There is a silver (bare) wire in the foil. False alarms will occur if moisture gets into the foil wrapper. Nicks in the outer cover and improper splices allow moisture to enter the cable. As moisture enters the cable, the resistance decreases. There must be greater than 20 meg (million) ohms from the silver wire to the colored wires.

The ideal installation is without any splices. The use of cable other than that, which is designed for the Drive-Alert System, is undesirable. Improper splices and unsuitable cable are major causes of false alarms. If splicing is unavoidable, splice the cable using a 3M SLIC-3M SPLICE KIT, or equivalent. The splice kit is available from Mier Products.

The sensing probe does not know if it is in or out of the ground, but it must remain absolutely motionless. Most sensing probes are buried about 6 inches deep and parallel to the driveway. Protect it from physical damage.

The cable is made for direct burial in the ground but make sure not to nick or cut the outer cover.

The sensing probe responds to changes in the earth's magnetic field. The signal produced by the coil is a few microvolts for a fraction of a second. The sensing probe and cable must not be within 3 feet of electric wires because they have changing magnetic fields of their own. Never bury sensing probe cable in the same trench with other electrical wires and wires for lights, bells, etc.

You may wish to place the sensing probe atop the ground in the general area of where you believe it would be an ideal installation, and connect the cable to the Master Control panel. This will allow you to test the system in application before final installation. It would be acceptable to leave the sensing probe and cable above the ground for a couple of days, but make certain it is not damaged during this period. This method should not be used permanently. See OPERATION INSTRUCTIONS of DA-503 and DA-504 for adjustments, which may be necessary.

The burial of the sensing probe is ideal in the center of the area being detected, but often this is not practical. If a new driveway is being put in, the sensing probe could be buried a minimum of 12-24 inches deep. In case you wish to place the sensor in the center of the drive, the cable and sensing probe could be placed in a larger piece of PVC to provide protection. The cable should also be protected whenever vehicles are to be moved over it.

The usual installation of the sensing probe is parallel to an already existing driveway. In this case, the sensing probe can be buried 6 inches deep, and the cable simply placed below the grassline. However, if vehicles are going to travel directly over the sensing probe and cable, the probe and cable should be buried deeper. The sensing probe may be placed up to 5,000 feet from the solid-state Master Control panel. Several sensing probes can be attached to one panel, but each additional sensing probe slightly reduces every sensing probe's ability to detect. The Drive-Alert will not know which sensing probe does the detecting.



The sensing probe is a 1" x 12" cylinder containing a sealed sensor. Be cautious when handling the sensor and particularly careful to not nick the cable attached to it.



Bury probe at least 6" deep

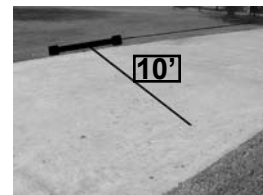

A typical installation is the probe 6 inches deep parallel to drive.

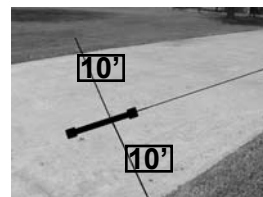

To extend your detection range install sensor in the center of drive.

RED	BLK	SHLD	NEG	+24V	NO	NC	C
--- SENSOR ---				UNREG			
1	2	3	4	5	6	7	8
DO NOT CONNECT TO 120V AC							



Connect the sensor's red, black and shield wires to the clearly marked terminals in the control panel.

Sensor Installation *continued*



When more than one sensing probe is used, connect the red and black wires in series. Connect the silver wires in parallel. The red wire from one cable is soldered to a black wire from another cable. The remaining red wire and black wire are attached to the Drive-Alert terminals. All silver wires are attached to the Drive-Alert terminals.

Keep the sensing probe, the cable and the solid state control panel at least 8 feet from heavy power lines, power panels, motors, arcing or sparking machinery, and radio transmitters. In some cases, moving the panel and/or cable a few feet can solve interference problems.

Mier
PRODUCTS, INC.

DA-503 Installation and Operation

The standard components that make up the DA-503 Drive-Alert are pictured. You may have purchased additional Remote Chimes, or the length of cable attached to the sensor may be longer than that illustrated. Please refer to Installation of Sensor for details on that portion of the installation. The Master Control may be attached to any wall with consideration given to the ability to easily connect the sensor wire and to have 120-volt power available. Installation of the Master Control should not be made near telephones or radio transmitters. The alarm signal generated by the DA-503 is transmitted to remotely located Chimes through the 120-volt power lines located in the building. The power line carrier units transmit and receive coded signals to activate selected receiving modules that provide the desired alarm signals. The ability to utilize existing power lines in a building (your house's wiring) eliminates the need for running separate wires to the chimes. In this model, a single X-10 Powerhouse Powerflash Interface, installed in the Master Control, sends the coded signal to the Remote Chimes via the power line wires.

Remote Chimes may be installed in any 120-volt outlet in a home, garage, barn, or outbuilding as long as it is on the same public utility transformer servicing the home. A typical installation is the location of the Master Control in a garage or utility room. Multiple Remote Chimes may be used, and generally are located in basements, family rooms, and bedrooms - wherever it is desirable for the sound to be heard.

Unique house and unit codes are utilized to direct the DA-503 alarm signal to these receivers throughout the building. The house and unit codes are preset at the factory for the transmitter and chime. The X-10 Powerflash transmitter installed in the Drive-Alert Control Panel, which controls the Remote Chimes, is set on Unit Code 1 and House Code B (Input set on A and Mode on 3). Remote Chimes should be set on the same codes - Unit Code 1 and House Code B.

The X-10 Remote Chime will sound three notes once during any transmitted alarm. The alarm signal must go off and turn back on before another chime cycle can occur.

Other house and unit codes can be used as long as both the receiver and transmitter are identically set. Such changes would be made if other X-10 Controls are utilized elsewhere in the building and cause interference with the DA-503 alarms.

The DA-503 has been adjusted for maximum sensitivity for the sensing probe and minimum time for the Remote Chime. To change these, open the Master Control, and find the components on the printed circuit board identified as "Time" and "Sensitivity," which are pictured on the diagram.

Follow the increase or decrease arrows to make adjustments. Use a small screwdriver and use only light pressure to obtain the desired settings. The red light on the LED 2 circuit board will remain on for one minute as a warm-up period when the DA-503 first receives power. The function of this circuit is to detect unwanted electrical interference during normal operation. It has been adjusted during testing, but if changes are desired, adjust the pot with a small screwdriver. Turn the pot clockwise until the red light turns on. Then turn the pot counterclockwise until the red light turns off. Continue turning the pot a small amount beyond that point.



DA-503 includes:

- **DA-503 Control Panel**
- **DA-058 Remote Chime**
- **DA-051-100 Sensor with 100 feet of cable**

Master Control Panel Adjustments

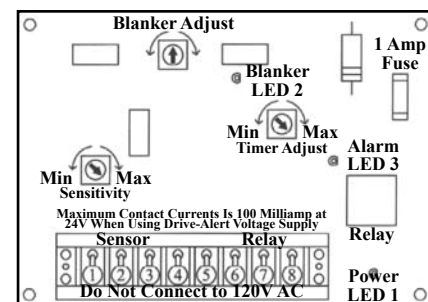

POWER LED 1 -
on at all times.

BLANKER ADJUST -
set at factory.

LED 2 -
on for one minute when powered up; out at all other times.

LED 3 -
indicates alarm.

DA-504 Installation and Operation

The standard components that make up the DA-504 Drive-Alert are pictured. You may have purchased additional Remote Chimes, Lamp or Light Switch Modules, or the length of cable attached to the sensor may be longer than that illustrated.

Please refer to Installation of Sensor on a preceding page for details on that portion of the installation. The Master Control may be attached to any wall with consideration given to the ability to easily connect the sensor wire and to have 120-volt power available. Installation of the Master Control should not be made near telephones or radio transmitters.

The alarm signal generated by the DA-504 is transmitted to remotely located Chimes, Lamp, or Light Switch Modules through the 120-volt power lines located in the building. The power line carrier units transmit and receive coded signals to activate selected receiving modules that provide the desired alarm signals.

The ability to utilize existing power lines in a building (your house's wiring) eliminates the need for running separate wires to the chimes or light controls. In this model, two X-10 Powerhouse Powerflash Interfaces, installed in the Master Control, send the coded signal to receivers via the power line wires. Remote Chimes or Lamp Modules may be installed in any 120-volt outlet in a home, garage, barn, or outbuilding as long as it is on the same public utility transformer servicing the home. A typical installation is the location of the Master Control in a garage or utility room. Multiple Remote Chimes or Lamp Modules may be used, and generally are located in basements, family rooms, and bedrooms - wherever it is desirable for the sound to be heard. Light Switch Modules are used to replace single-pole switches that generally control outside lights up to 500 watts.

Unique house and unit codes are utilized to direct the DA-504 alarm signal to these receivers throughout the building. The house and unit codes are preset at the factory for the transmitter and chime or lamp receiver.

The X-10 Powerhouse transmitter, installed on the right as the Drive-Alert Control Panel is mounted, controls signals that may be transmitted to Remote Chimes. This transmitter is set on Unit Code 1 and House Code B (Input set on A and Mode on 3). Remote Chimes should be set on the same codes - Unit Code 1 and House Code B. The Remote Chimes will sound three notes once during any transmitted alarm. The alarm signal must go off and turn back on before another chime cycle can occur.

The X-10 Powerhouse, installed on the left, controls the transmission of signals to Lamp Modules and Light Wall Switches. Lamp Modules plug into any 120-volt outlet and a lamp is then plugged into the module. A Wall Switch Module may be used to replace an existing switch in a home, and receives the Drive-Alert's signals to turn on the lights, which that switch controls. The period of time these lights remain on is adjustable from one to 45 minutes. (Read below on how to adjust the time these devices remain on). The transmitter controlling these light modules is set on Unit Code 1 and House Code C. The Input is set on A and Mode is on 1. The Lamp Modules and Light Wall Switches are identically set - Unit Code 1 and House Code C.

Other house and unit codes can be used as long as both the receiver and transmitter are identically set. Such changes would be made if other X-10 Controls are utilized elsewhere in the building and cause interference with the DA-504 alarms.

The DA-504 has been adjusted for maximum sensitivity for the sensing probe and minimum time for the Remote Chime. To change these, open the Master Control, and find the components on the printed circuit board identified as "Time" and "Sensitivity," which are pictured on the diagram. Follow the increase or



DA-504 includes:

- **DA-504**
Control Panel
- **DA-058**
Remote Chime
- **DA-051-100**
Sensor with 100 feet of cable

and the choice of one

- **DA-059**
Wall Light Switch
OR
- **DA-060**
Lamp Module

DA-504 Installation *continued*

or decrease arrows to make adjustments. Use a small screwdriver and use only light pressure to obtain the desired settings.

To alter the period of time the Lamp Modules or Light Wall Switches stay on, refer to the Timer Control Board illustration. Following the decrease or increase arrows, use a small screwdriver to adjust accordingly. Since the adjustment period is from one to 45 minutes, it is suggested you make only minor movements until reaching the time desired.

The red light on the circuit board, identified as Noise-Blanker, will remain on for one minute as a warm-up period when the DA-504 first receives power. The function of this board is to detect unwanted electrical interference during normal operation. It has been adjusted during testing, but if changes are desired, adjust the pot with a small screwdriver. Turn the pot clockwise until the red light turns on. Then turn the pot counterclockwise until the red light turns off. Continue turning the pot a small amount beyond that point.

DA-503 & DA-504 Accessories

Additional **DA-058 Remote Chimes** may be used with the DA-503 and the DA-504 Drive-Alert Warning Systems. One unit is included with either system, but depending on the size and design of the home, it may be desirable to install other chimes. For example, if your home is multi-story, has a basement, or is ranch-style, additional chimes may ensure you know when the system is in alarm condition.



DA-058 Remote Chime

The use of **DA-060 Lamp Modules** have multiple benefits because it not only alerts you when the Drive-Alert is activated, but also if the lamp is located in front of a window, may tell the person driving the vehicle that his presence has been detected. A lamp simply plugs into the Lamp Module, and may be located wherever there are 120-volt outlets available. It also serves those who are hard-of-hearing by visibly alerting them. The Lamp Module can be used with the DA-504.



DA-060 Lamp Module

Use of **DA-059 Wall Light Switch Modules** can be of extreme importance, and are recommended for use with the DA-504. This switch replaces existing wall switches, and when it receives the signal from the Drive-Alert Control Panel, lights controlled by this switch will stay on for an adjustable period of 1 to 45 minutes. Many times this switch is used for outside lights to warn vehicle drivers they have been detected and to light the way when a homeowner returns home. The Module is rated at 500 watts.



DA-059 Wall Switch

Trouble-Shooting Hints

Here are some suggestions to determine if your Drive-Alert System requires service. Most problems can be readily isolated.

Intermittent, constant alarm

When an intermittent or constant alarm occurs, disconnect the plug from the 120-volt power. Open the door to models DA-503 or DA-504 and disconnect the red and black sensor wires from the terminal strip. Reconnect the 120-volt power. Observe the LED (red light - No. 2) on the circuit board identified as Noise Blanker. It will remain on for about 1 minute, then go out. Thereafter, the alarm should be silent. **DO NOT TOUCH** the R and B terminals during this time. If the alarm sounds as soon as this LED goes out, the unit is malfunctioning and should be returned for repair.

When no alarm sounds

When no alarm sounds, check the LED (red light - No. 1) on the printed circuit board identified as Drive-Alert Control Panel Board. If it does not glow, check the 1 amp fuse on the circuit board - near the black relay. If open, replace with another 1 amp fuse. If red light remains out, check for AC power at the AC outlet. If power is present, the unit is malfunctioning and should be returned for repair.

Checking sensor probe

To check the sensor probe for false alarm conditions, disconnect the red, black and silver wires from the terminal strip. Use an ohmmeter to measure sensor coil resistance. Measure red to black leads, which should read 700-1200 ohms. When two or more probes are in series add the resistance for the correct value. Two probes would equal 1200 ohms. If resistance is correct, measure the leakage resistance from the red lead to the silver (shield) lead. The meter should show infinite resistance as though no connection exists. Use a high resistance ohmmeter. If analog, x 10,000 range. If digital, unit should have a 40 million-ohm capability. Any meter deflection that shows indicates moisture has entered the cable through a break in the outer insulation and the red and black conductors. Digital meters and analog meters with a low range may not indicate a problem when the leakage resistance is 2 to 10 million ohms (this can cause false alarms).

Checking remote modules

If one of the remote modules, a Remote Chime, Lamp Module, or Wall Light Switch does not activate when the Drive-Alert senses a vehicle, generally the problem is the codes are not properly set. First, make certain that the Unit Code and House Code on the remote device is set to correspond with those same codes on the Powerhouse Interface in the Master Control panel. If you have the DA-504 Drive-Alert, the Powerhouse on the left controls the transmission of signals to Lamp Modules and Wall Light Switches. The Powerhouse on the right controls signals to the Remote Chimes. Secondly, make certain the Input and Mode on the Powerhouse Interfaces are set correctly - the one on the left should be Input A and Mode 1, and the one on the right should be Input A and Mode 3.

**Need Technical Support - Call us at 1-800-473-0213
Monday-Friday from 8:00 am - 5:00 pm EST**



Explanation of LEDs

Explanation of LEDs (red lights) used in DA-503 and DA-504 Drive-Alert Systems. See numbers marked on illustrations.

No. 1 - This light glows as long as power is available and the internal fuse is good. Models DA-503 and DA-504.

No. 2 - In normal operation, this light will not activate. It will glow for one minute when the Master Control is first powered up. Models DA-503 and DA-504.

No. 3 - This light glows each time the Drive-Alert detects a vehicle, and will remain on for 3-5 seconds, then goes out. Models DA-503 and DA-504.

No. 4 - This light glows for the period of time the Timer Control board is set, but comes on only after No. 2 light goes out. Model DA-504.

No. 5 - This light glows momentarily as the timing function begins then goes out. Model DA-504.

Master Control Panel Adjustments

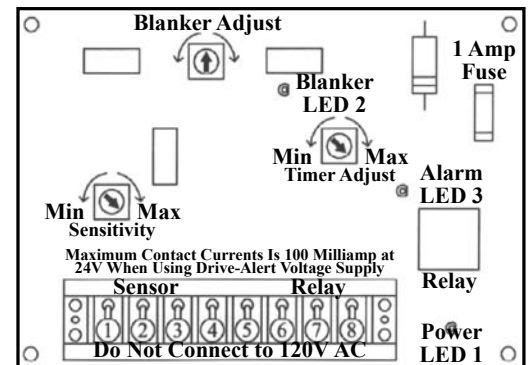

Timer Board Adjustments

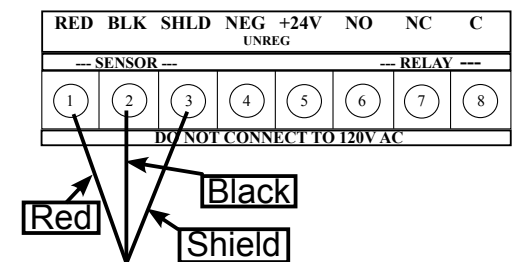
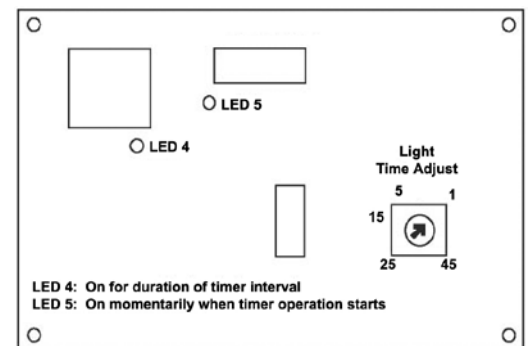

Connect the sensor's red, black and shield wires to the clearly marked terminals in the control panel.