



Superior Ring Bending Tool



Superior Ring Bending Tool

The superior ring bending tool is designed to make bending easy and efficient. It consists of the main unit and a set of matched posts and dies, which together give accurate repeatable results every time. It comes complete with several round posts and matching dies in sizes 12mm, 14mm, 16mm, 18mm, 20mm, and 22mm diameter. A 90° square post and a 60° diamond shaped post. Your set may also come with the optional matching Delrin dies, for added versatility. PepeTools are constantly striving to improve all of their products, so slight variations may occur as well as special value deals and bundled kits. However, in all cases the operation is the same. Its use is fairly intuitive, but the following tips will help you get great results every time

Set up.

The tool is suitable for left or right handed use, simply rotate the handle as appropriate. The main unit needs to be firmly affixed to a solid surface, and you have several options.

Option 1. The unit can be fixed directly to your workbench by using screws, or bolts through the four countersunk holes and into your worktop.

Do not place a screw into the post hole.

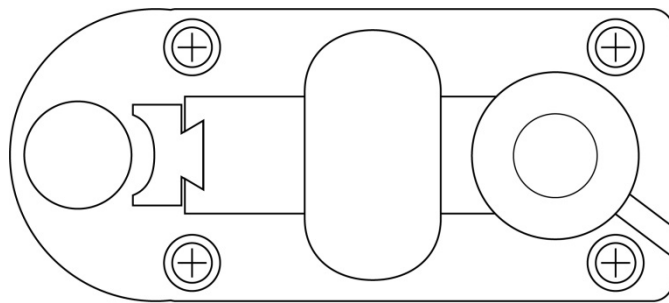

Option 2. An alternative is to screw the unit into a plank of wood. The plank in turn can be G-clamped to your workbench. Whilst not quite as secure, this method does allow for portability, without damaging the workbench. *Tip, use rubber grip matting underneath the plank to aid grip and protect your worktop.*

Option 3. If you have a fixed bench vice, the bender can be placed on top of the vice jaws and tightly clamped underneath. Note the recessed step underneath the unit. This allows for a very secure yet flexible option.

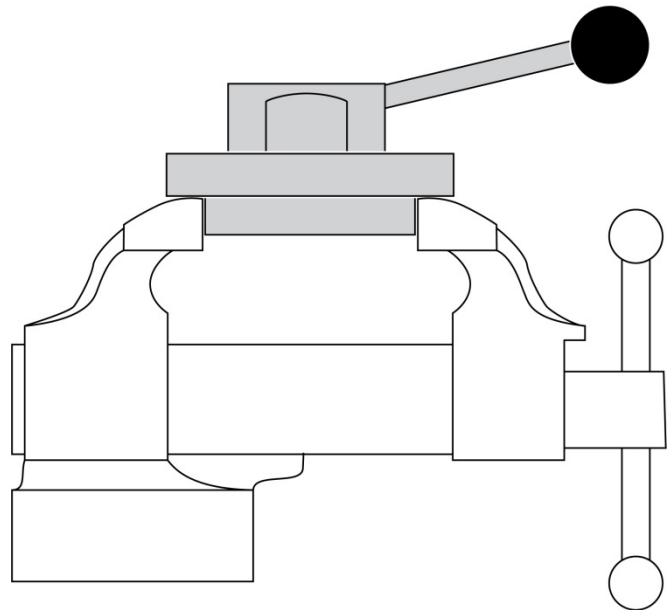

Superior Ring Bending Tool

Bending rings

In order to bend rings, begin with a strip of annealed metal. Ideally the strip should not be wider than the working height of the post. Depending on how you chose to size your rings, you may generally prefer to use a post a little smaller than your final ring size.

Insert the post into the depression on the main unit. It should fit snugly. Note the different posts all have the same size base. Each post also has a matching die. Insert this by slotting the stud at the rear of the die into the slot on the main unit. The die should wrap around the post.

Move the handle to open the gap between the post and the die. Insert your strip between the two, ensuring that the edge is flat against the surface of the unit at all times. This will ensure that the bend is at 90 degrees to the strip and not at an angle.

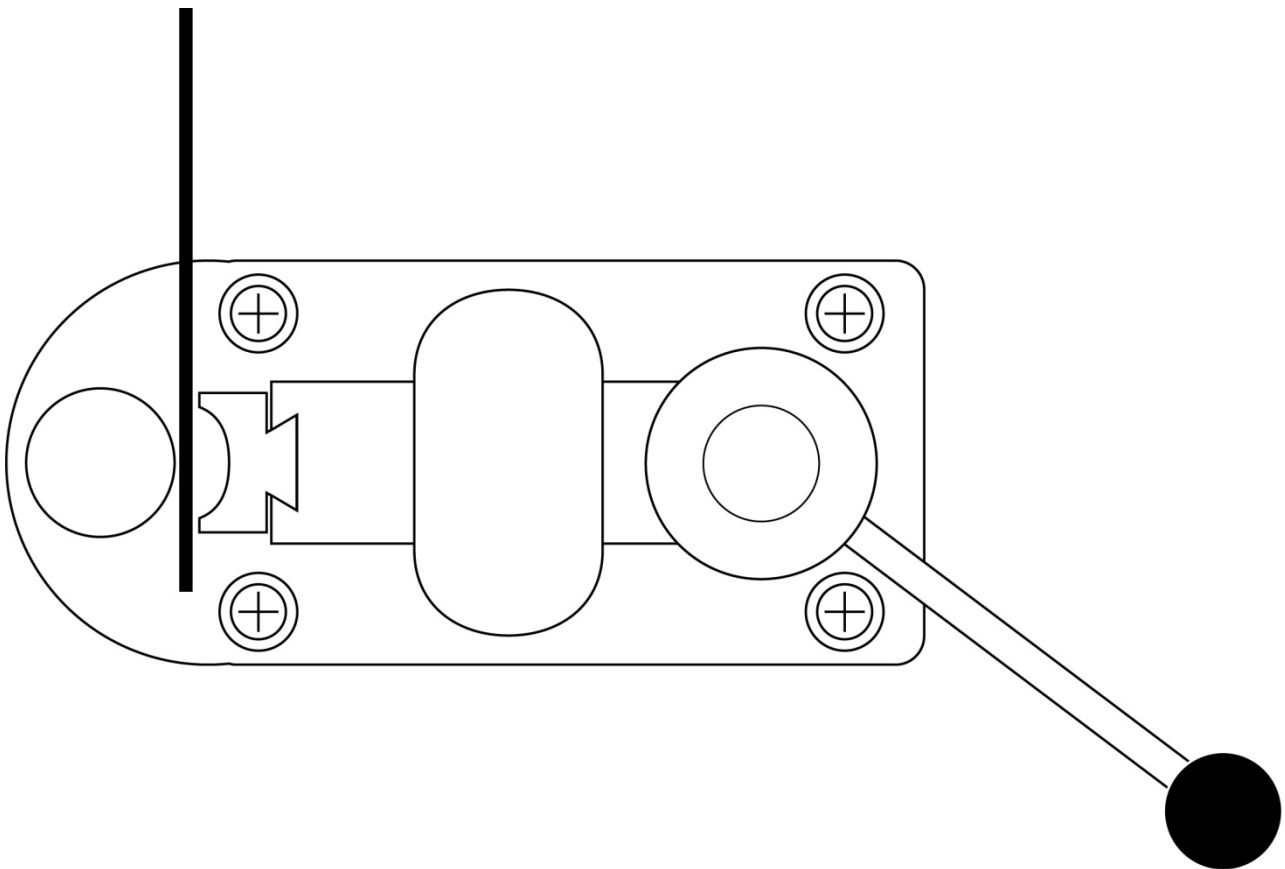

Tip. It can be tricky to start at the very end so lay the strip all the way across the die, as shown and make your first bend a little way in from the end of your strip. Bend the end later, once you have a curve started.

Superior Ring Bending Tool

Pull the handle towards the post and you will note the piston slides, pushing the die against the strip and bending it around the post. Release the pressure, and reposition your strip a few mm further along. Pull the lever again to bend. Repeat this action, moving the strip along and bending a little at a time. Once you have a half curve, insert the very end of your strip to ensure a smooth curve right to the end.

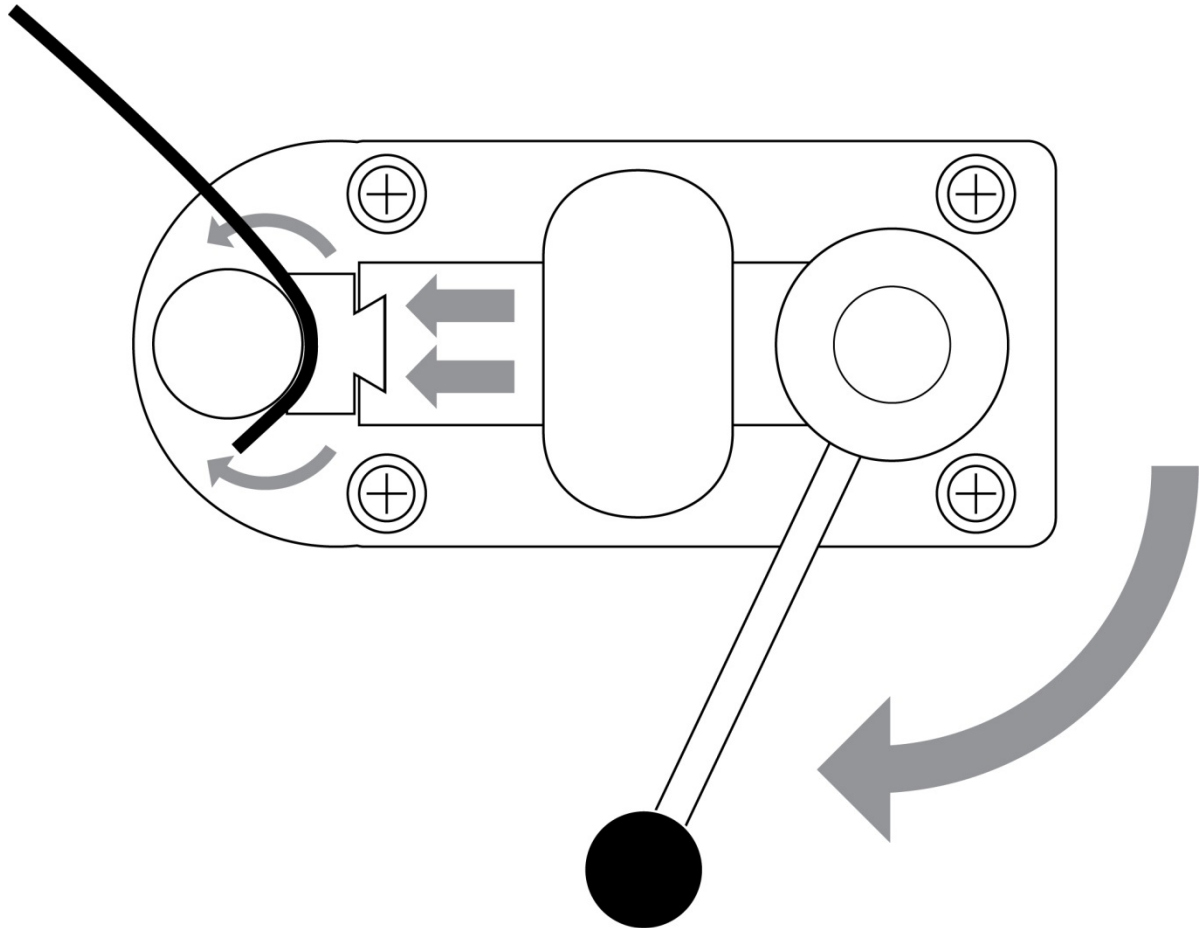

Eventually, the strip will wrap entirely around the post. Be careful to avoid any marking where the strip overlaps itself. Check the ring size you require, using a mandrel. Cut the strip where the overlap occurs and solder as normal.

Tip. The outer diameter of a thick ring may be much larger than the inner diameter. In this instance, try using a larger die with the same post, as this will give a smoother curve E.g. if using 2mm thick strip, on a 20mm post then try it with a larger 22mm die.

Tough metals.

If your strip is tough. Apply pressure to hold the strip firmly between the die and the post, whilst using your other hand to bend the strip around the post. This can be repeated to get the desired effect. Using the bender as a clamp and bending the strip with your hand. Note that although many people use this method to make spoon rings, the unit is designed for working with soft precious metals. For tougher items like this steel or thick cutlery, perhaps consider the Pepetools ring shank bender, which is much larger and offers more leverage.

Square Bends

The set also comes with a square post and die. These can be used to make perfect right angled bends. Insert the post and die and with no strip inserted, pull the handle and make sure that the square post slots perfectly into the die. Mark on your strip where you want the bend and place this mark on the inner corner of the post. As always, keep your strip flat on the surface to create a straight bend across the strip. Similar to starting a curve, the strip should protrude across the die, in order to fully bend both sides. Partially inserting just the very end of strip the may not give the desired effect.

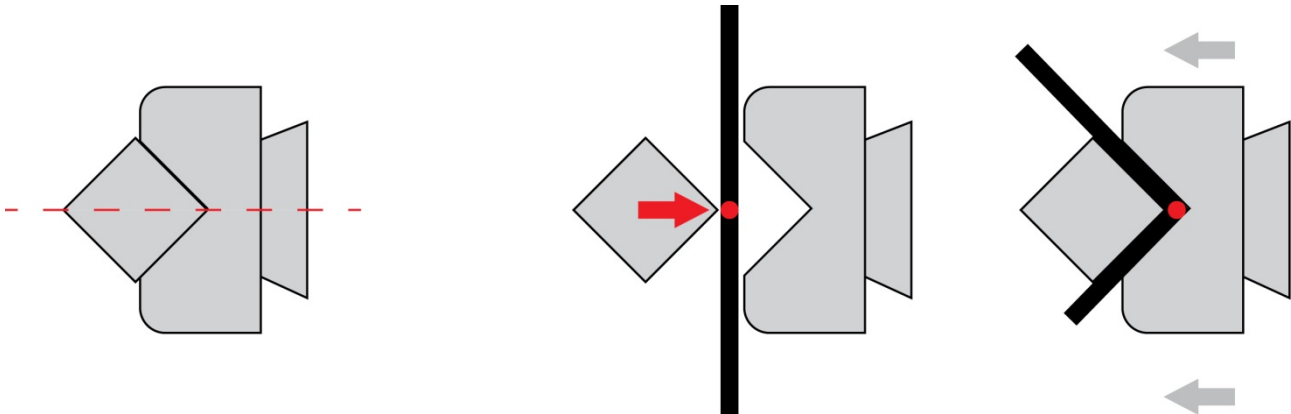

Likewise the 60° diamond shaped die can be used to create a sharper bend in the same way. This is ideal for bent findings such as chain ends or bails, as it ensures a perfect and accurate starting bend.

Delrin dies. PepeTools also offer a set of identical posts and dies made of Delrin. This is a tough thermoplastic, which gives the same bending capabilities but reduces the chance of marking delicate metals. Ideal for softer metals, profiled ring shanks or textured strips.

Maintenance. The superior ring bender requires virtually no maintenance. An occasional light coating of household oil is all that is required. Apply with a soft cloth, remembering to coat the posts and dies too. With no post inserted, move the lever back and forth, whilst applying a few drops of oil around the moving block (piston). Check that it moves smoothly and springs back when you move the lever. If your work has been quenched, always ensure it is fully dry before bending and avoid any moisture on the tool.

Storage. If you are not using the tool for a prolonged time. Coat all parts with a light application of oil, as above and store in a sealed plastic container in a dry place. *Top TIP! If you have any of those small silica gel packets which you often get in packaging, pop them into the sealed box and these will help keep your tools dry and rust free.* Check out Pepetools.com for the latest tips, advice and videos.

Written and illustrated by Dave Wilson.



www.pepetools.com