

Laying Out a Wholecloth Quilt

Before you even start designing or marking your wholecloth quilt, there is one important step to take and that is establishing your center point and horizontal and vertical lines. These are VERY important and will make your designing process SO much easier. These guidelines apply to both standard wholecloth quilts as well as linen wholecloth quilts.

1. Press your fabric flat. I often use Niagra sizing or Best Press to give the fabric a little more body.
2. Hold your pressed fabric up and fold it in half width wise and then in half again lengthwise. You are quartering it by folding it in half in each direction. Your fabric is rarely perfectly square or straight so don't stress about having your edges and corners perfectly matched.
3. Take your folded/quartered piece and place it back on the ironing board and press your folds into firm creases. You have now established the center of your wholecloth quilt and also created horizontal and vertical guidelines that all of your designing will be based off of.
4. Open up your fabric and lay your long ruler down on these pressed lines. With your quilt marking pen, trace these lines so they are visible. All of your designing will be based off of these lines...they are critical!

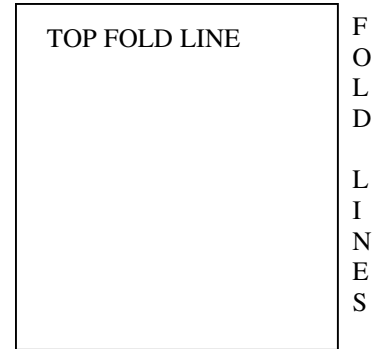

5. I highly recommend that you mark additional lines at a 45 degree going from corner to corner.

All four lines will be used to keep your medallion design in the middle (if that's where you want it) and establish guidelines to keep your designs straight and lined up.

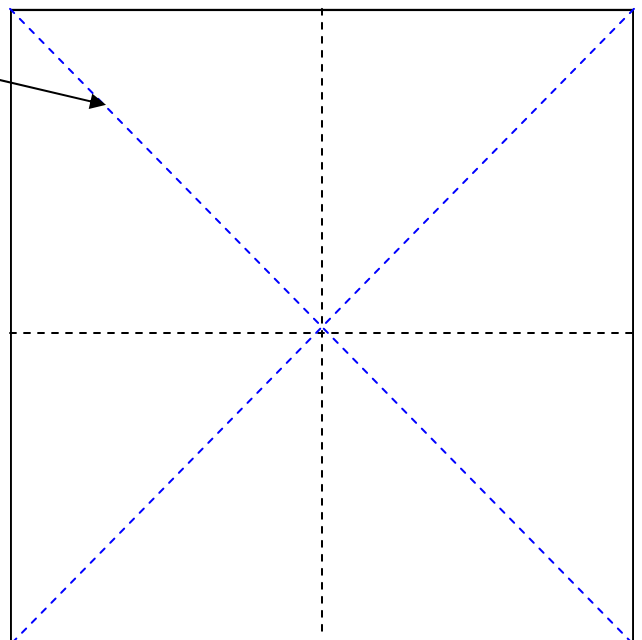

The most common style of wholecloth quilts is a medallion. Rather than creating a repetitive or overall design, you are focusing on one main design surrounded by one or more borders or corners. This is where your four main points of design can really come in to play!

I've chosen a Mariners Compass design for the medallion of my wholecloth quilt and decided to have it in the center of my piece. I used my marked guidelines for placement.

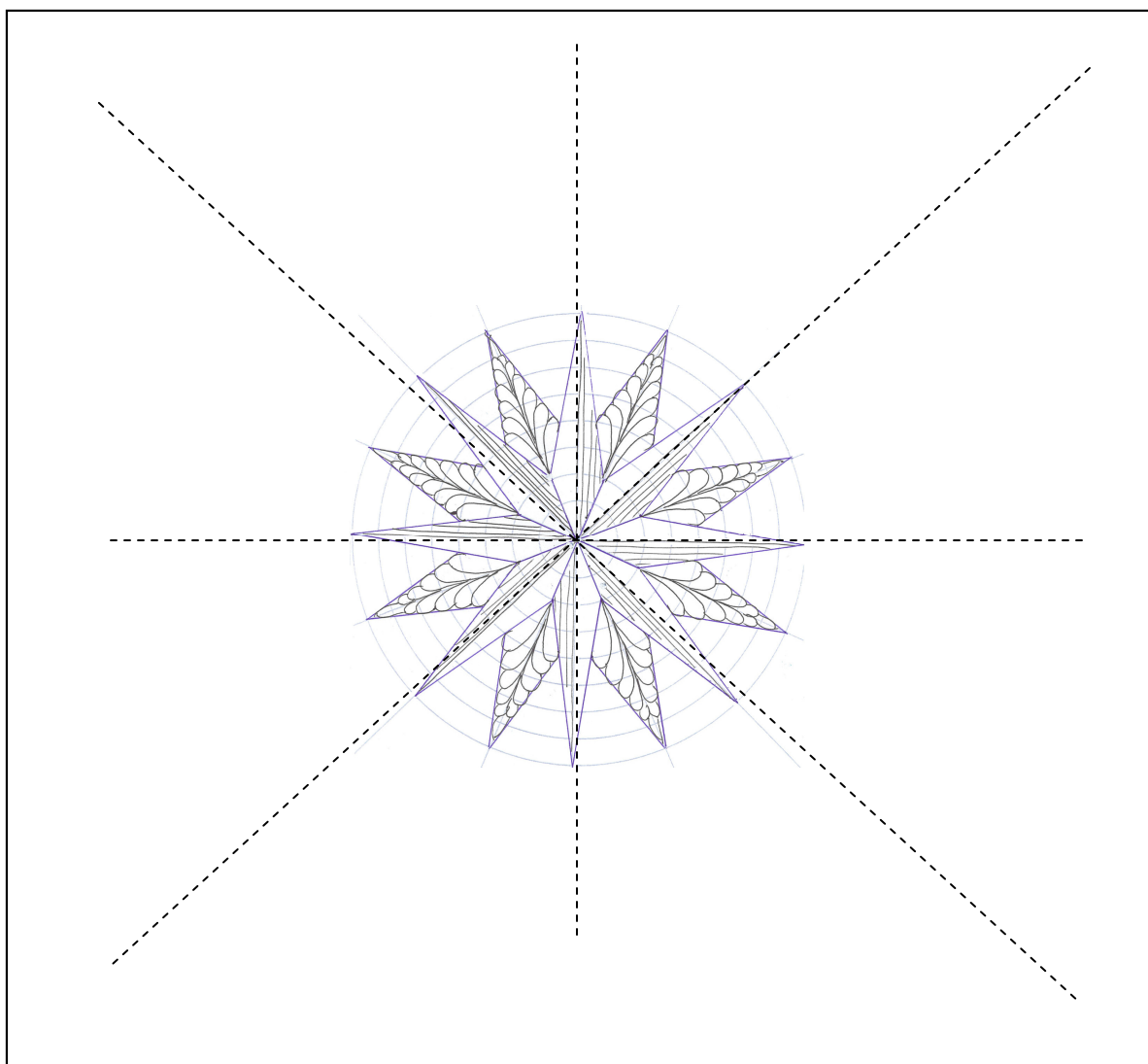

Sometimes it's fun to add additional lines around your medallion just to strengthen it a bit and add more detail. I love a three-line repeat and love how this looks around the compass. You can add any kind of detail or border around your medallion...the sky is the limit! These additional lines also make it easy when you are quilting backgrounds...you can take the background right up to the last line. Makes it easy for traveling.

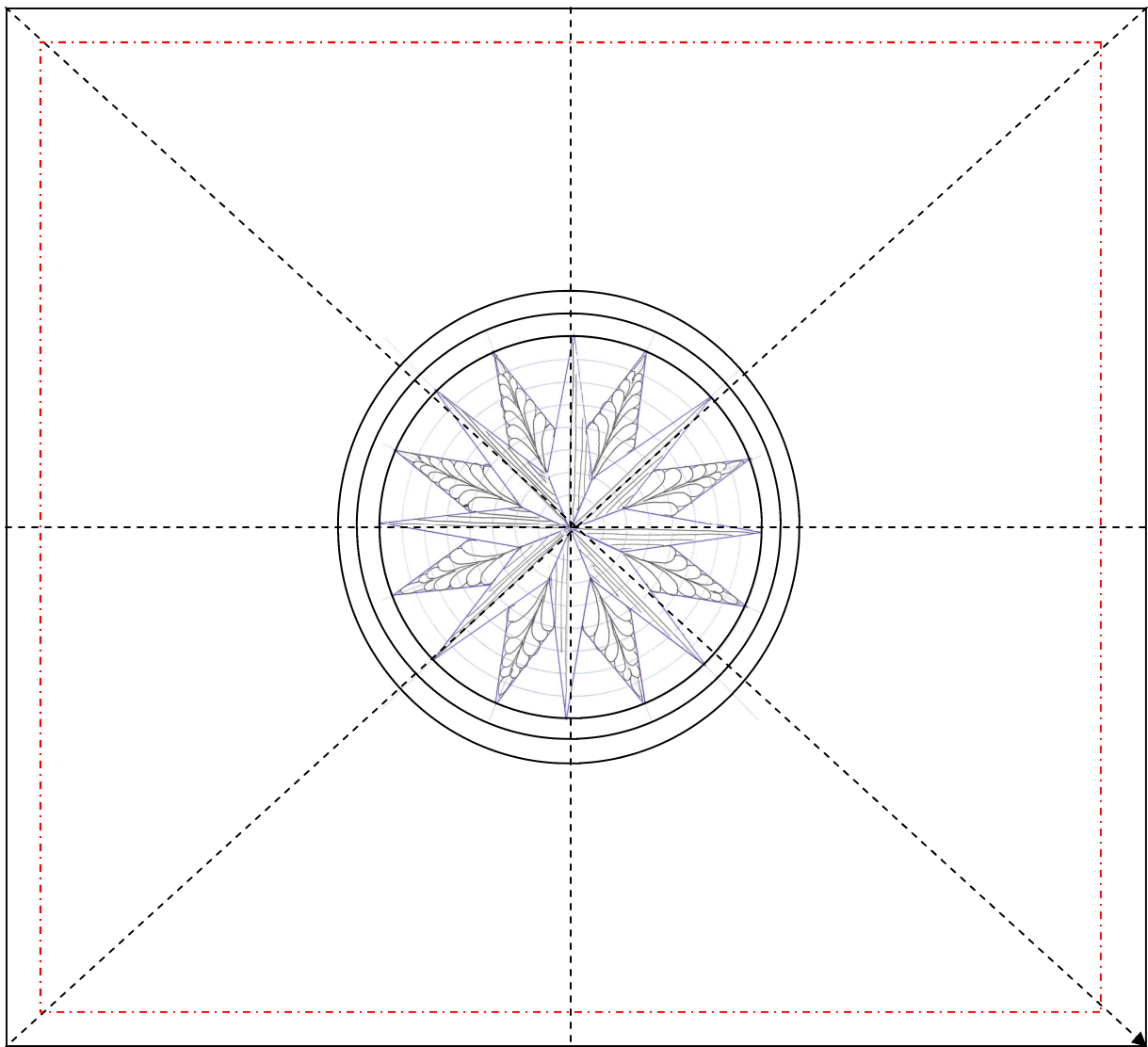

Now it's time to choose and lay out a border should you want one. This is simple to do in a pieced top because you have a pieced border. It's just as easy for a wholecloth quilt.

The first step is to choose your border design.

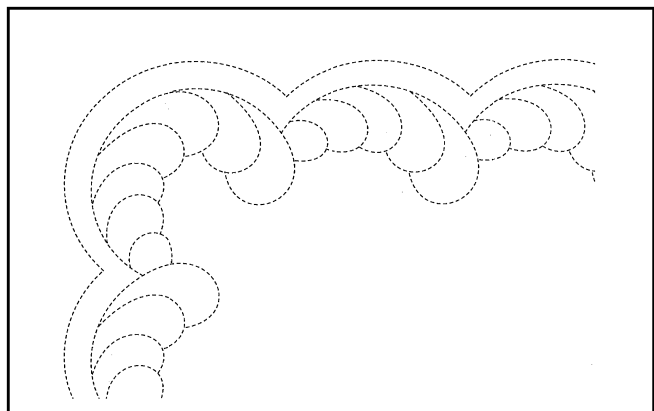

Determine how far out you want the outside edge of your border to be. Be sure to leave at least 2" from the outside edge of your border to the outside raw edge of your fabric for squaring up later on. In this case I want the outside edge of my border to be 20" from center. Using a ruler, I measure out from both the horizontal and vertical lines and mark a dashed line all the way around at 20". This is my guide for lining up and marking my border.

Mark all four corners first and "fudge to fit" in the middle. Please refer to the "Making Borders Fit" handout that accompanies this.

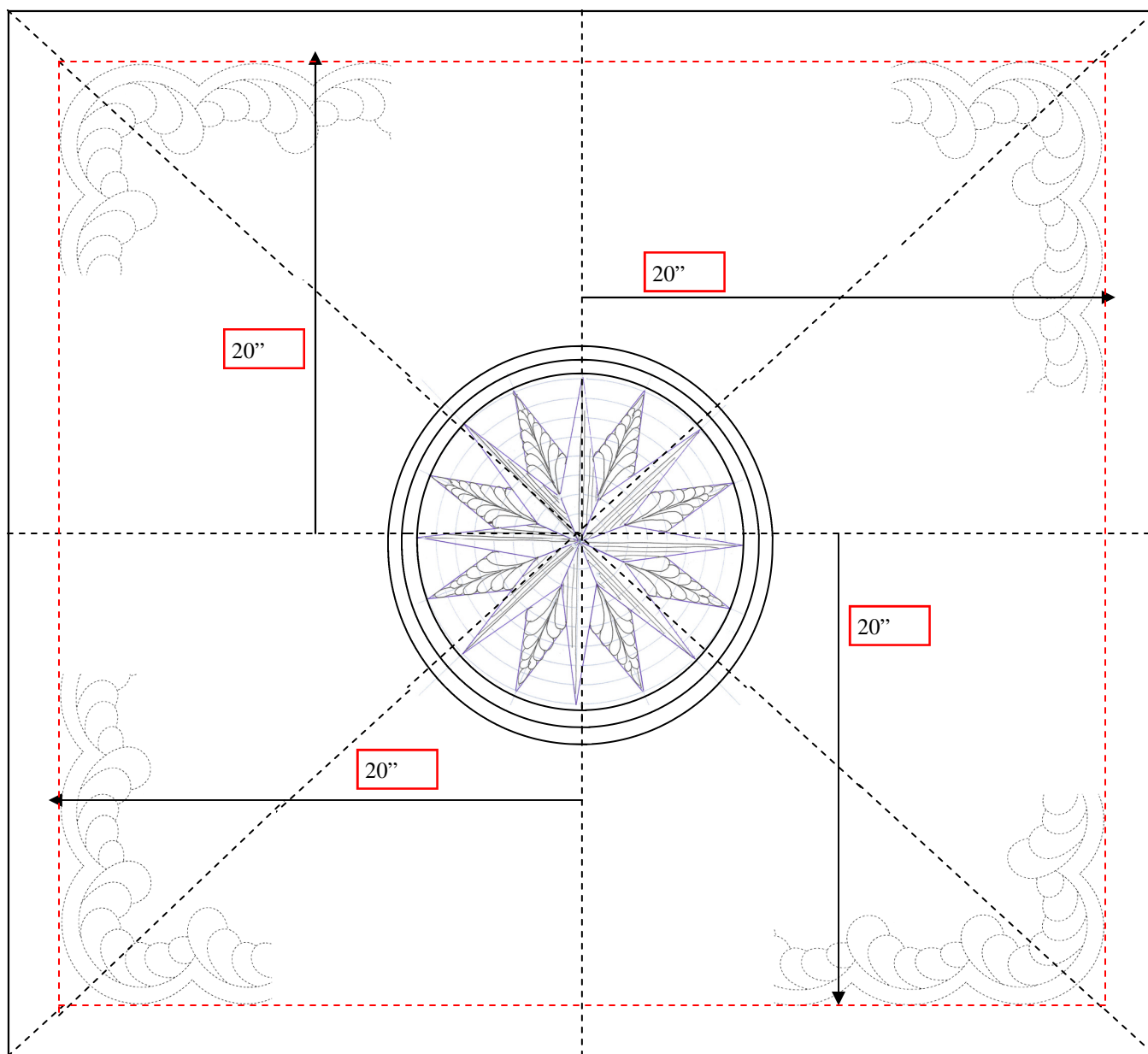

This is what a very basic medallion wholecloth quilt may look like. Although it's pretty, it doesn't excite me too much. The medallion in the middle seems to be a "floater" Nothing is grounding it and there's no dimension. Let me show you how we can easily fix this!

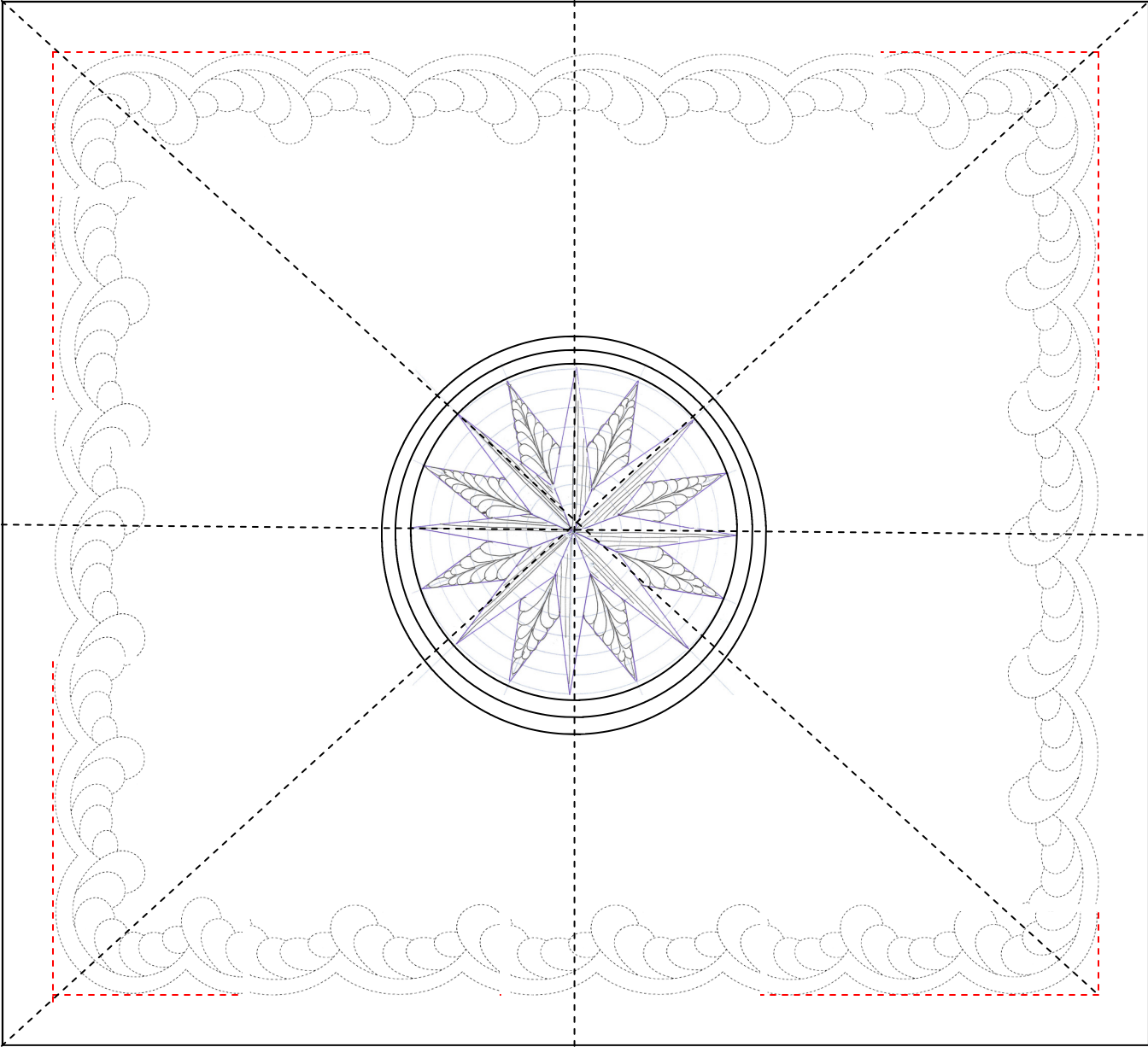

Using my horizontal and vertical lines as a guide, I marked another set of triple lines on point with one line going “underneath” the circles that surround the medallion.

I’ve added dimension to this piece and used up a little bit more space in the wide open area. Let’s play with the open area by adding MORE!

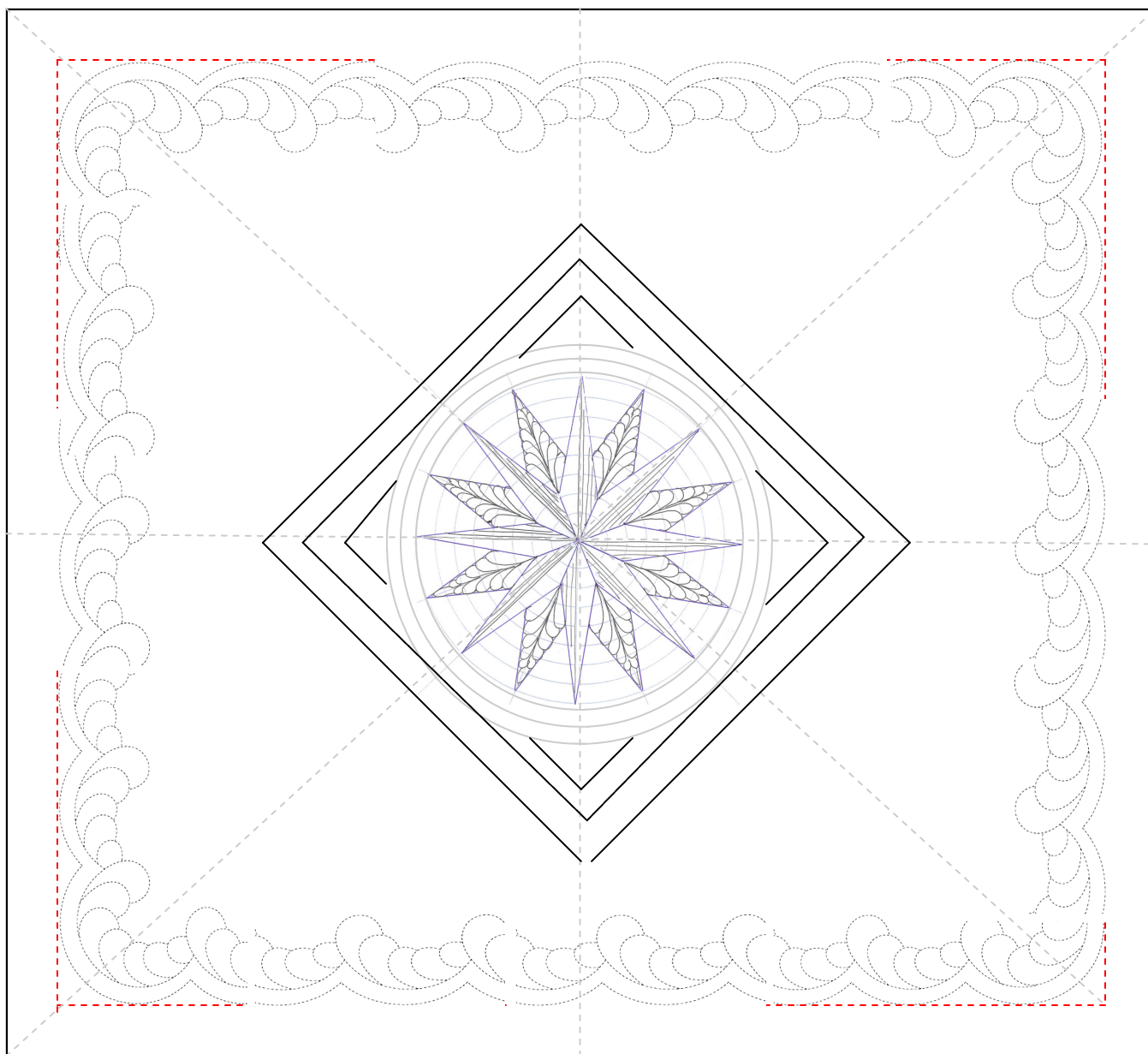

I added a large circular swag to go around the medallion. This divides up more space, provides movement and dimension and also repeats the circular design in the middle.

Because this huge area was divided into separate areas I am inclined to use several different background designs to add even more interest!

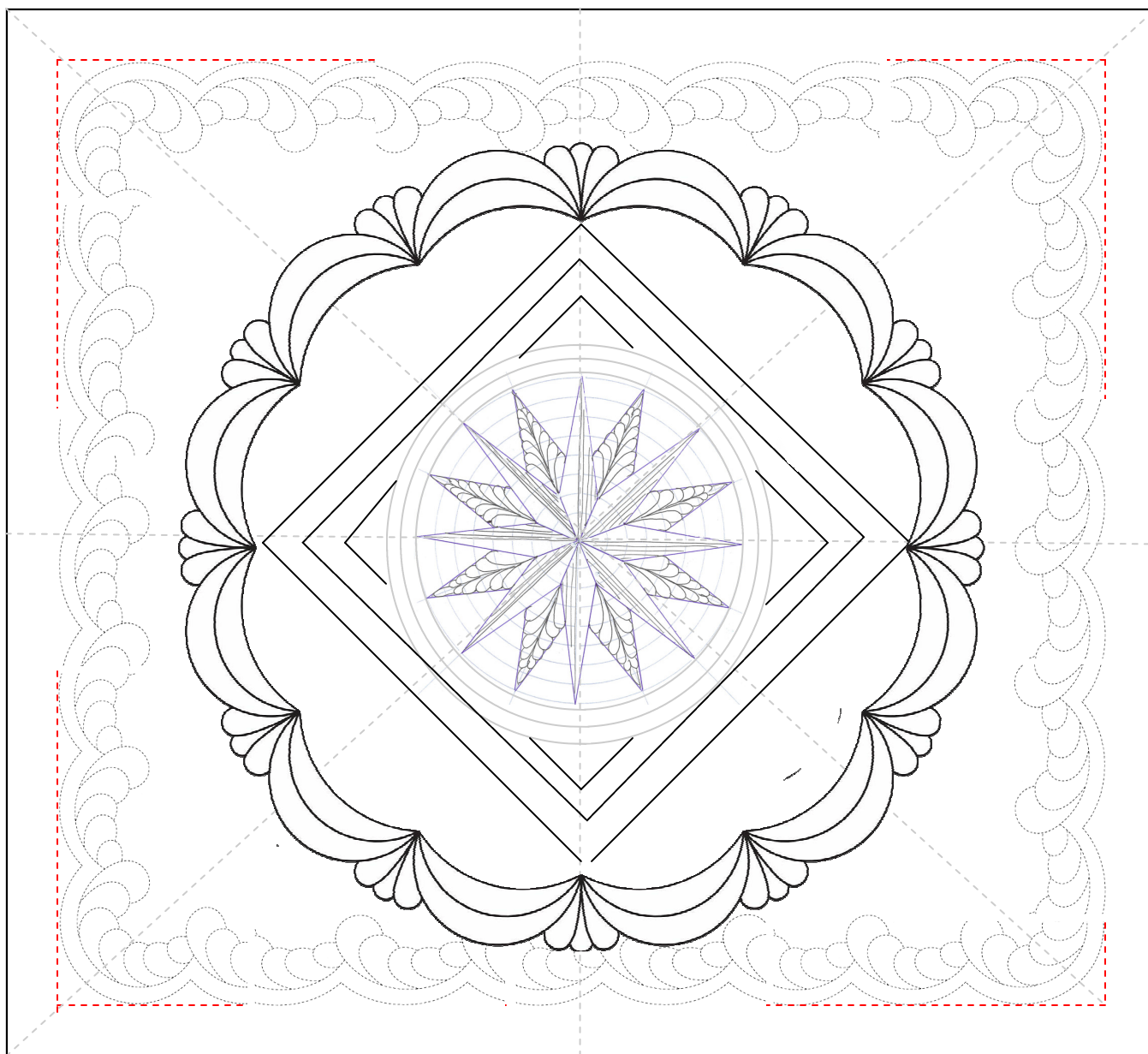

Use the basic layout for a repetitive design wholecloth quilt...the same one we used for the medallion style.

1. Choose your square design and place it in the middle of your quilt being sure to line up the center and corners with your marked guidelines.
2. Now repeat that design horizontally and vertically always lining up your design with the marked guidelines. Keep repeating the design until you have filled your space. See the beautiful secondary design that is created by the repetition???? Very cool!
3. If you have a pieced block quilt you can place your design on your blocks and repeat it in every single block and you will end up with the same overall design.

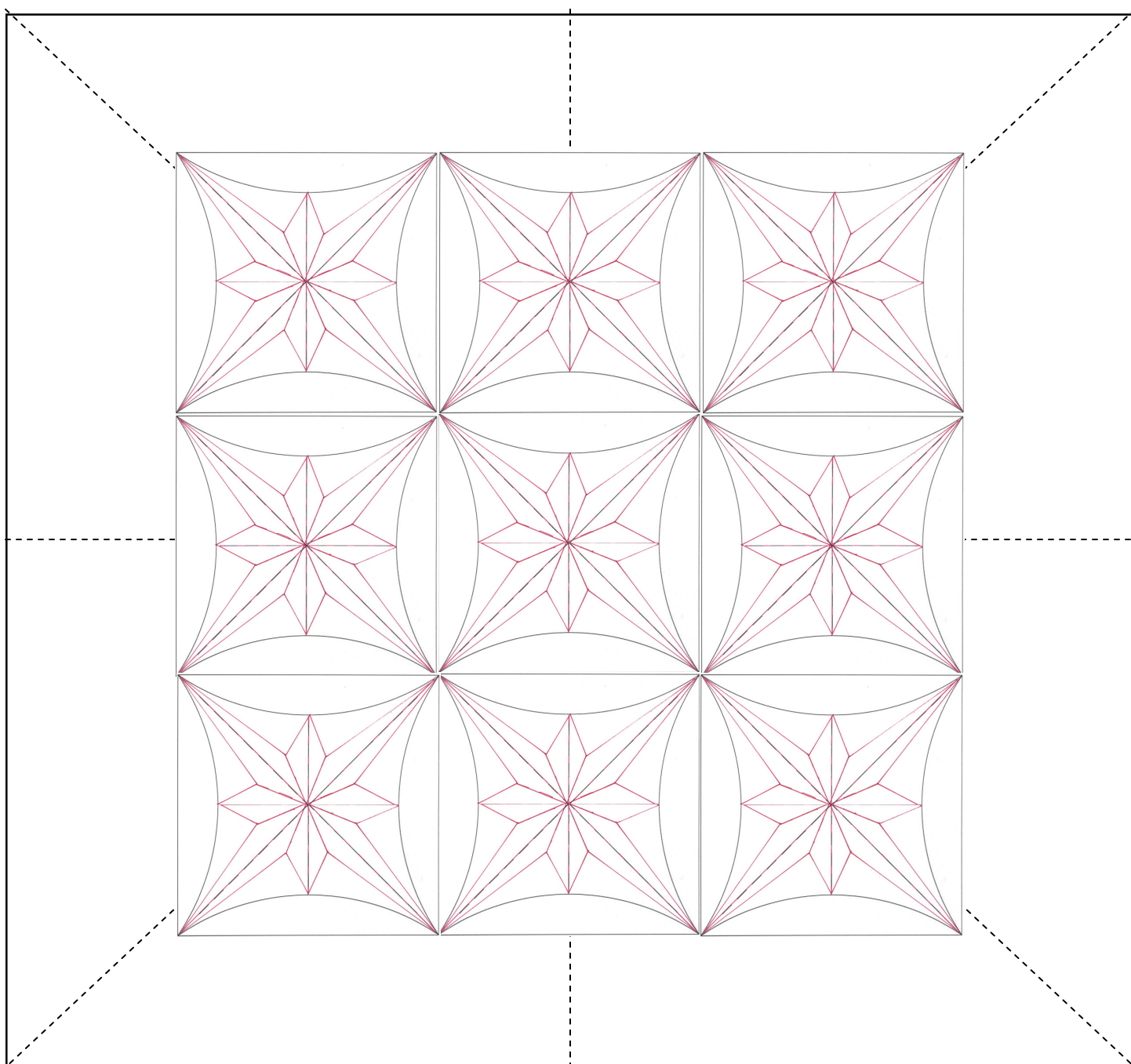

The previous page showed one square design repeated horizontally and vertically. When I audition designs I always try them “on point” too. You get a totally different effect. You still line your design up on your marked guidelines to keep everything lined up. Keep repeating your design until your space is filled.

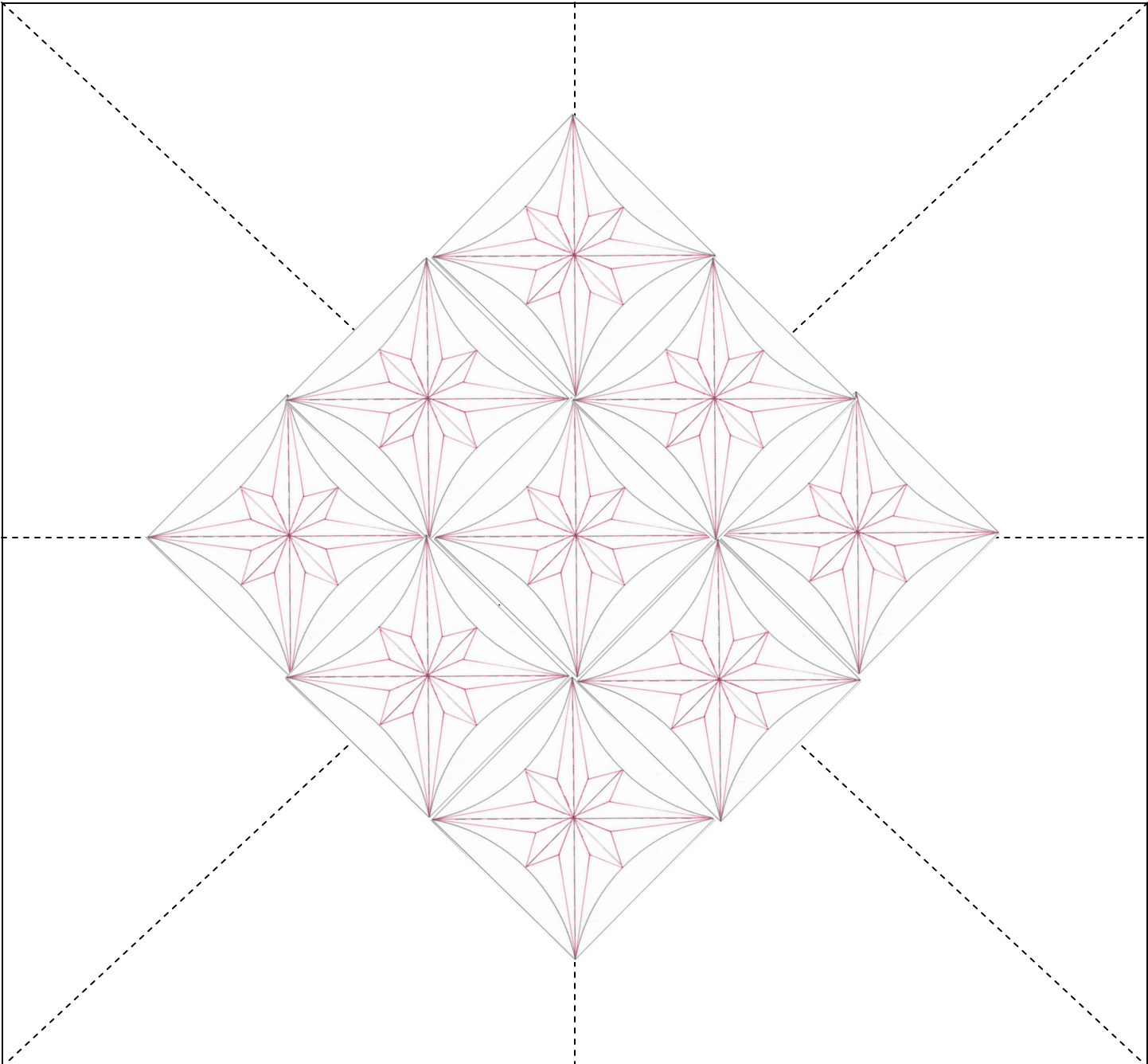

Remember the circle swag we used on the previous medallion quilt? You can do the same thing here!

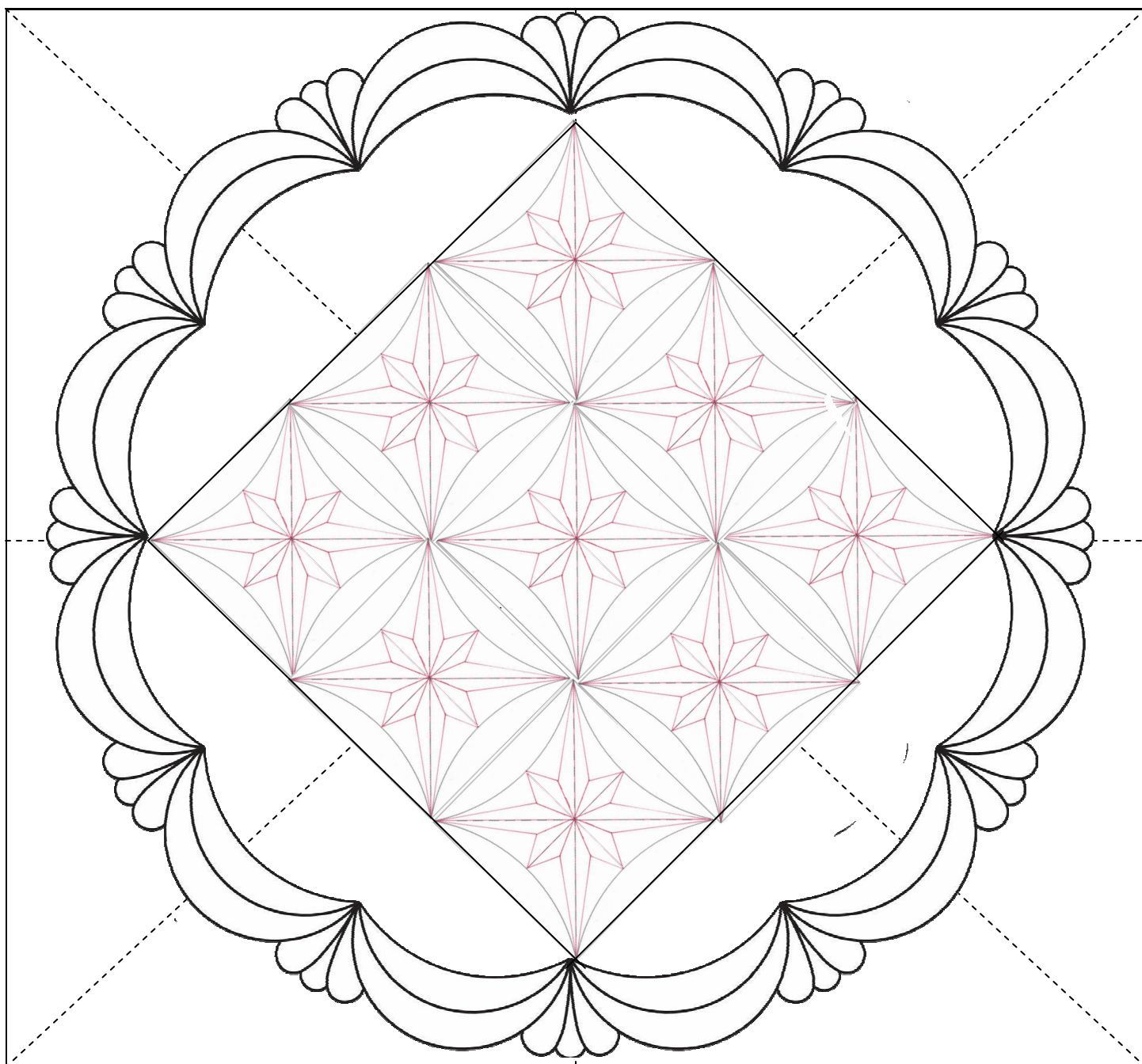

Order of Quilting

Stabilizing and quilting a wholecloth quilt is different than a pieced quilt. I recommend that you quilt your piece from the “big bones” to the “little bones”. Do your major designs first throughout the entire piece and start working your way down to the smaller designs. By quilting the designs evenly throughout the entire quilt, big bones to little bones, it should be relatively flat when you are done. Your background designs are always last. I have numbered the designs in the order I would quilt this piece.

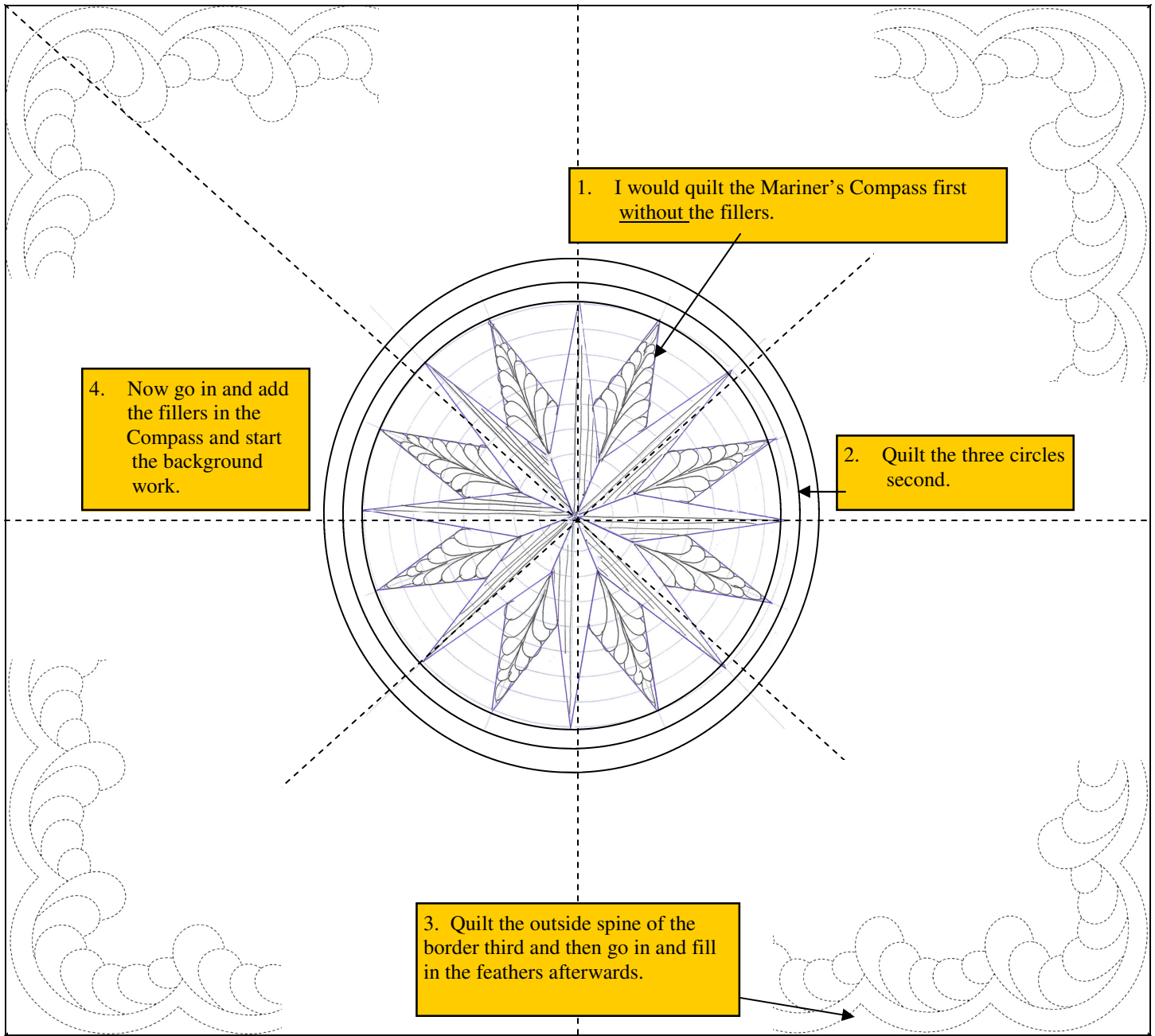

HOBBS BONDED FIBERS

PREMIUM BATTINGS MADE TO QUILTERS SPECIFICATIONS

Listed in order as samples are collated

Heirloom Natural with scrim: Heirloom Natural is a high grade cotton combined with a thin scrim binder to add strength. This batting can be hand or machine quilted up to 10" apart and will shrink 3-5%.

Heirloom & Tuscany Bleached Cotton: Both of these products utilize a fine bleached cotton that is needle punched for strength. These battings can be hand or machine quilted up to 4" apart and will shrink 3-5%.

Heirloom Natural and Tuscany Unbleached Cotton: These battings are made with a high grade of American grown cotton. They can be hand or machine quilted up to 4" apart and will shrink 3-5%.

Heirloom Premium-Cotton Blend: Heirloom Premium 80/20 was the first blended batting on the market. Made with 80% cotton and 20% fine denier polyester, this batting is needle punched and resin bonded for added strength over traditional cotton batting. Can be hand or machine quilted up to 4" apart and will shrink 2-3%..

Heirloom 80/20 Black Cotton: Made for dark quilts, our Heirloom 80/20 Black is made the same as our Heirloom 80/20 Premium only with black cotton and black polyester. Can be hand or machine quilted up to 4" apart and will shrink 2-3%.

Heirloom 80/20 Bleached Cotton: Made for white or light colored quilts, Heirloom 80/20 Bleached is made the same as our Heirloom 80/20 Premium only with bleached cotton in place of natural cotton. Can be hand or machine quilted up to 4" apart and will shrink 2-3%.

Heirloom 80/20 Fusible Cotton: Heirloom 80/20 Fusible is an iron on batting that is fusible on both sides. It is made the same as our Heirloom 80/20 Premium only we add a fusible resin. You can iron both top and bottom at the same time and peel it loose and iron again if needed. Can be hand or machine quilted up to 4" apart and will shrink 2-3%.

Heirloom & Tuscany Wool: These wool battings are manufactured using the finest washable wool available. The wool is lightly resin bonded to help prevent fiber migration. Can be hand or machine quilted up to 4" apart and will shrink 0-3%.

Tuscany Silk: Tuscany Silk is arguable the finest batting we manufacture. It's made with 90% Tussah silk and 10% fine denier polyester. Tuscany Silk is lightweight and washable. Can be hand or machine quilted and will shrink 3-5%.

Thermore: Thermore is a very thin, drapeable, migration free batting developed for clothing, miniatures, and any other project were a thin, drapeable batting is needed. Can be hand or machine quilted up to 8" apart and will not shrink.

Polydown: Polydown is made with a very fine denier polyester that makes it soft and drapeable. It's resin bonded to help prevent bearding and migration. Can be hand or machine quilted up to 6" apart and will not shrink.

Tuscany Polyester: Along with Polydown, Tuscany Polyester is in a class of its own. It also uses a small denier, siliconized polyester and is very easy to work with. Can be hand or machine quilted up to 6" apart and will not shrink.

Tuscany Cotton Wool: Blend batting is made with fine USA cotton blended with the very best superwash wool which eliminates most of the shrinkage. The blend is 80% cotton with 20% superwash wool. Can be Quilted 4" a-part with shrinkage of approximately 3%. Excellent for both hand and machine quilting. Wash finished project on gentle and flat dry. Pre-washing the batt is not recommended.

P.O.Box 2521 Waco, TX 76702-2521

Phone: 254-741-0040 Fax: 254-772-7238

Email:sales@hobbsbondedfibers.com Web: www.hobbsbondedfibers.com

*** Pre Washing of Batting is NOT Recommended ***

HOBBS BONDED FIBERS

P.O. Box 2521 Waco, TX 76710
254-741-0040 Fax: 254-772-7238



HOBBS QUILT BATTING
QUALITY BATTING SINCE 1978

PRODUCTS	PRODUCT TYPE	APPROXIMATE LOFT	SHRINKAGE	MAXIMUM DISTANCE BETWEEN STITCHES	FOR HAND QUILTING	FOR MACHINE QUILTING	FOR DARK FABRICS	FOR LIGHT FABRICS
POLYESTER								
Tuscany®	Resin Bonded Siliconized Poly	1/4"	None	6"	Excellent	Excellent	Fair Pre-Test	Excellent
Cloudloft®	Resin Bonded Poly	1/2 - 5/8"	None	6"	Fair	Excellent	Fair Pre-Test	Excellent
Polydown®	Resin Bonded Poly Siliconized Fibers	1/4"	None	4"	Excellent	Excellent	Fair Pre-Test	Excellent
Thermore®	Resin Bonded Poly Patented Fibers	1/16"	None	9"	Excellent	Excellent	Excellent	Excellent
COTTON								
Heirloom® Premium	80% Cotton, 20% Poly-Resin Bonded & needlepunched	1/8 +"	3%	4"	Excellent	Excellent	Excellent	Excellent
Heirloom® 80/20 Black	80% Cotton, 20% Poly-Resin Bonded & needlepunched	1/8"	3%	4"	Excellent	Excellent	Excellent	Not Recommended
Heirloom® 80/20 Bleached	80% Cotton, 20% Poly-Resin Bonded & needlepunched	1/8"	3%	4"	Excellent	Excellent	Fair Pre-Test	Excellent
Heirloom® 80/20 Fusible	80% Cotton, 20% Poly-Resin Bonded & needlepunched	1/8"	3%	4"	Excellent	Excellent	Excellent	Excellent
Heirloom® & Tuscany® Unbleached	Needlepunched	1/8"	3-5%	4"	Excellent	Excellent	Excellent	Caution! Pre-Test
Heirloom® Natural <small>with scrim binder</small>	Needlepunched with scrim binder	1/8"	3-5%	8-10"	Caution! Pre-Test	Excellent	Excellent	Caution! Pre-Test
Heirloom® & Tuscany® Bleached	Needlepunched	1/8"	3-5%	4"	Excellent	Excellent	Fair Pre-Test	Excellent
WOOL								
Heirloom® & Tuscany® Wool	Washable Wool Resin Bonded	1/4-3/8"	None	4"	Excellent	Excellent	Caution! Pre-Test	Excellent
SILK								
Tuscany® Silk	90% Silk, 10% Poly-Resin Bonded & needlepunched	1/8 +"	5%	4"	Excellent	Excellent	Caution! Pre-Test	Excellent
Tuscany Cotton / Wool	80% Cotton, 20% Super Wash Wool Resin Bonded	1/4"	3%	4"	Excellent	Excellent	Caution! Pre-Test	Excellent

Splitting a Wool Batt

Wool has become one of my favorite battings. Wool has a memory, it won't hold creases and it also gives your quilted designs a beautiful trapunto-type of effect. My quilts and class samples are all packed tightly in suitcases when I travel. Because of the memory that wool possesses, my quilts arrive at my destination nearly crease free and because it is so lightweight, my quilts don't add a lot of weight to my suitcases.

I love the weight and drape of batting and love how a quilt feels when it is heavily quilted. Many years ago I decided I wanted the weight and drape of a cotton batting BUT I also wanted the puff of the wool. Why couldn't I have both?

I decided to split a wool batting in half. I call this my "gourmet batting". I place my cotton batting down first. Then I place a half-thickness wool batting on TOP of the cotton. You can place this half-thickness wool on top of any kind of batting you want...it's your "recipe" and your quilt.

A student recently asked me if I place the smooth side of the split batt up or down and I've done both...it didn't seem to make a difference. Wool is a very forgiving fiber. When you split it you will find that you have "hills and valleys" of batting...no worries. That's normal and it doesn't matter when you place it in your quilt sandwich.

I advise against "butting up" other non-wool battings next to each other in a quilt sandwich in order to make them large enough for the quilt...you may end up with a ridge or an empty space that shows thru to the top. (*There is a fusible tape on the market for fusing two batts together*). A wool batt is different. I NEVER throw wool parts away...I save everything. If I'm a little short on a batting I can grab another scrap of wool, slightly overlap, give them a bit of a massage, and they are linked together so to speak. The wool fibers will interconnect.

Please refer to my FB Live video where I show you how I split and layer this.

HOBBS TUSCAN COLLECTION

The Ultimate Quilt Batting
Developed for Discriminating Quilters

100% WOOL BATTING

- Quilts Magnificently by Hand or Machine.
- Quilts Up to 4 Inches Apart. • Washable.
- Breathes Naturally. • Resin Bonded.

- | | | |
|--|--|---|
| <input type="checkbox"/> CRIB - 45" X 60" | <input checked="" type="checkbox"/> TWIN - 72" X 96" | <input type="checkbox"/> QUEEN - 96" X 108" |
| <input type="checkbox"/> THROW - 60" X 60" | <input type="checkbox"/> FULL - 81" X 96" | <input type="checkbox"/> KING - 120" X 120" |

Exclusively by HOBBS - Web: www.hobbsbatting.com - Email: sales@hobbsbondedfibers.com
Crafts Products Division P. O. Box 2521 Waco, Texas 76702-2521 254-741-0040

I use this batting a LOT...love it! It won't add any weight to a quilt but it does drape nicely if heavily quilted. The memory of the wool helps to eliminate crease lines when your quilt is folded.

HOBBS TUSCAN COLLECTION

The Ultimate Quilt Batting
Developed for Discriminating Quilters

SILK BLEND

Endorsed by
"THE SILK EXPERIENCE"

- A Blend of Silk and Fine Polyester • Washable* - Shrinks 3-5%
- Quilts Magnificently by Hand or Machine
- Lightweight - Amazing Drape, Even When Heavily Stitched!
- Breathes Naturally - Great for All Climates!
- Bonded - Quilters May Quilt Up to 4 Inches Apart

- | | | |
|--|---|--|
| <input type="checkbox"/> CRIB - 45" X 60" | <input type="checkbox"/> TWIN - 72" X 96" | <input checked="" type="checkbox"/> QUEEN - 96" X 108" |
| <input type="checkbox"/> THROW - 60" X 60" | <input type="checkbox"/> FULL - 81" X 96" | <input type="checkbox"/> KING - 120" X 120" |

Exclusively by HOBBS, makers of Heirloom Premium Batting - Web: www.hobbsbatting.com - Email: sales@hobbsbondedfibers.com
Crafts Products Division 200 Commerce Dr. Waco, Texas 76710 254-741-0040

*Please see care instructions on reverse side.

Mmmmmmm...Just the word "silk" makes me moan just a bit. I've used this batting on my last four linen wholecloth quilts and have fallen head over heels in love with it. It provides a very nice heavy drape to my pieces. It is quickly becoming my favorite batting.