

# Mayhem and Living Link Frames

## Assembly Instructions and Maintenance Manual



**SPOT**

# Table of Contents

Warnings and Precautions	3
Component Compatibility Chart	3
Tools Required for Assembly of Parts onto Frame	4
A. Internal (“stealth”) Dropper Seatpost Routing	5
A0. External Dropper Seatpost Routing	7
B. Rear Brake Hose Routing	9
C. Rear Derailleur Cable Routing	9
D. Front Derailleur Cable Routing and Installation	12
E. Bottom Bracket Installation	14
Tools Required for Maintenance	15
Leaf Spring Related Precautions	16
F. Rear Derailleur Hanger Removal/Replacement	17
G. Rear Shock Removal/Replacement	18
H. Rear Triangle Removal	19
I. Upper Link Removal	23
J. Upper Link Disassembly	24
K. Main Pivot Bearing Replacement	25
L. Upper Link Bearing Replacement	27
M. Reinstalling the Upper Link	29
N. Reinstalling the Rear Triangle	32
Rollik Frame Parts Reference / Exploded View	39

# Warning

Like any sport, bicycling involves risk of injury and damage. By choosing to ride a bicycle, you assume the responsibility for that risk, so you need to know—and to practice—the rules of safe and responsible riding and of proper use and maintenance. Proper use and maintenance of your bicycle reduces the risk of injury or death.

All bicycles should be assembled and maintained by an authorized bicycle mechanic. If you are not qualified to assemble, inspect, and maintain your bicycle, please visit your favorite local bike shop or contact Spot Brand for a referral to a qualified bicycle technician in your area.

This guide covers the details specific to working with your Living Link™ frame. It does not address complete bicycle assembly, fitting, inspection, maintenance, or riding techniques. Please refer to the Spot Brand Bicycle Owner’s Manual for further details.

Under no circumstances shall Spot Brand LLC be held liable for direct, incidental, or consequential damages, including, without limitation, damages for personal injury, property damage, or economic losses, whether based on contract, warranty, negligence, product liability, or any other theory.

## Mayhem Component Compatibility

Your Mayhem frame was designed to work with the following components. Other components may be compatible, but fitment is not guaranteed. For questions regarding component compatibility for parts not listed below please contact Spot.

COMPONENT	FIT/STANDARD
HEADSET	UPPER: ZS44, LOWER: ZS56
BOTTOM BRACKET	73mm THREADED
SEATPOST	Ø31.6, INTERNAL DROPPER ROUTING
1X DRIVETRAIN	52mm "BOOST" CHAINLINE REQUIRED, DIRECT MOUNT CHAINRING REQUIRED, 34t MAX
REAR HUB	12 X 148mm, SRAM MAXLE REAR AXLE INCLUDED
REAR BRAKE	Ø160 NATIVE POST MOUNT, Ø180mm MAX ROTOR DIAMETER
REAR TIRE 29"	29 X 2.3" / 58mm MAX WIDTH. NOTE THAT ACTUAL TIRE WIDTHS CAN VARY FROM PRINTED SIZES
REAR TIRE 650b PLUS	650b X 2.8" / 70mm MAX WIDTH. NOTE THAT ACTUAL TIRE WIDTHS CAN VARY FROM PRINTED SIZES
REAR SHOCK	200 X 57, FRONT EYELET: Ø8 X 20, REAR EYELET Ø8 X 40
SEATPOST COLLAR	Ø35.0mm
FORK TRAVEL	130-140mm
WATER BOTTLE	2X BOTTLE MOUNTS, ONE ABOVE AND ONE BELOW THE DOWNTUBE
CHAIN GUIDE	ISCG-05 TABS, LARGE UPPER GUIDES MAY NOT FIT. CONTACT SPOT FOR RECOMMENDATIONS

# Assembly

## Tools Required:

- Hex wrenches / bits, sizes: 5mm, 6mm
- Torx wrenches / bits, sizes: T25
- Torque wrench
- Headset Press
- Bottom Bracket Installation Tools—May vary by BB brand and model
- High-Lubricity Waterproof Grease—We recommend Slick Honey
- Isopropyl or denatured alcohol—90% or higher concentration
- Strong, thin adhesive tape—electrical tap, packaging tape, etc.



# A. Internal (“stealth”) Dropper Seatpost Routing

## IMPORTANT:

Install your internal dropper seatpost cable/hose before installing the bottom bracket assembly. Your Mayhem frame is supplied with a lead tube installed in place of the dropper seatpost cable/hose to ease installation. Please do not remove the lead tube until the dropper seatpost cable is installed.



1. Make sure your seatpost collar is installed on the frame. The seatpost cable/hose is easiest to install by feeding from the seat tube to the head tube, but can be fed starting at the head tube if necessary. Tape the seatpost cable housing or hydraulic hose to the lead tube at the seat tube end. Make sure to clean the end of the cable/hose and the lead tube with alcohol before taping. Tape the two together in line, and wrap the tape several times around the junction for sufficient contact.
2. While feeding the seatpost cable/hose into the seat tube, gently pull the lead tube out of the port near the head tube. If excessive resistance is met, the tape joint may be too bulky and should be reduced. The cable/hose must curve around a relatively small radius between the seat tube and the down tube. It is recommended to help the seatpost cable/hose around this curve with a finger or two through the access port in the BB shell.

3. Continue to feed the seatpost cable/hose while gently pulling the lead tube from the port near the head tube. When the seatpost cable emerges from the port, remove the tape and store the lead tube in a safe place:



4. Proceed to install your dropper seatpost per the seatpost manufacturer's instructions. *You may wish to install other components on the frame before completing the dropper post installation.*

# A0. External Dropper Seatpost Routing

## IMPORTANT:

Your Mayhem frame was designed to use an internally (“stealth”) routed dropper seatpost. If you wish to use an externally routed seatpost, you may do so by following these tips:

1. It will be necessary to use a stick-on cable guide on the outside of the seat tube to properly secure the seatpost cable/line to the frame. This can be procured at your local bike shop or online. Before installing the stick-on guide, *thoroughly* clean the frame in the area where you’ll attach the guide with isopropyl or denatured alcohol. Once the alcohol is dry, apply the stick-on cable guide to the seat tube as shown:



2. The external seatpost cable/hose will share cable saddles on the down tube. Route and attach the line as shown:



**IMPORTANT:**

Ensure that the seatpost cable/hose does not interfere with any moving suspension components, crank arms, or rear tire during cycling of the suspension.

## B. Rear Brake Hose Routing

1. Begin by installing the rear brake caliper and any applicable adapter if using a rotor larger than 160mm. Please note the Mayhem frame is not compatible with rotors larger than 180mm.
2. Route the rear brake line starting from the caliper- attaching it to the rear triangle using the supplied zip ties on the cable saddles, and the screw in the p-clip.
3. Leaving a small amount of slack between the p-clip and the front triangle, continue to route the line up the down tube using the supplied zip ties.

## C. Rear Derailleur Cable Routing

1. Begin by feeding the rear derailleur cable housing into the rear port on the top of the drive side chainstay near the rear axle. It will emerge from the forward port on the chainstay yoke behind the bottom bracket:

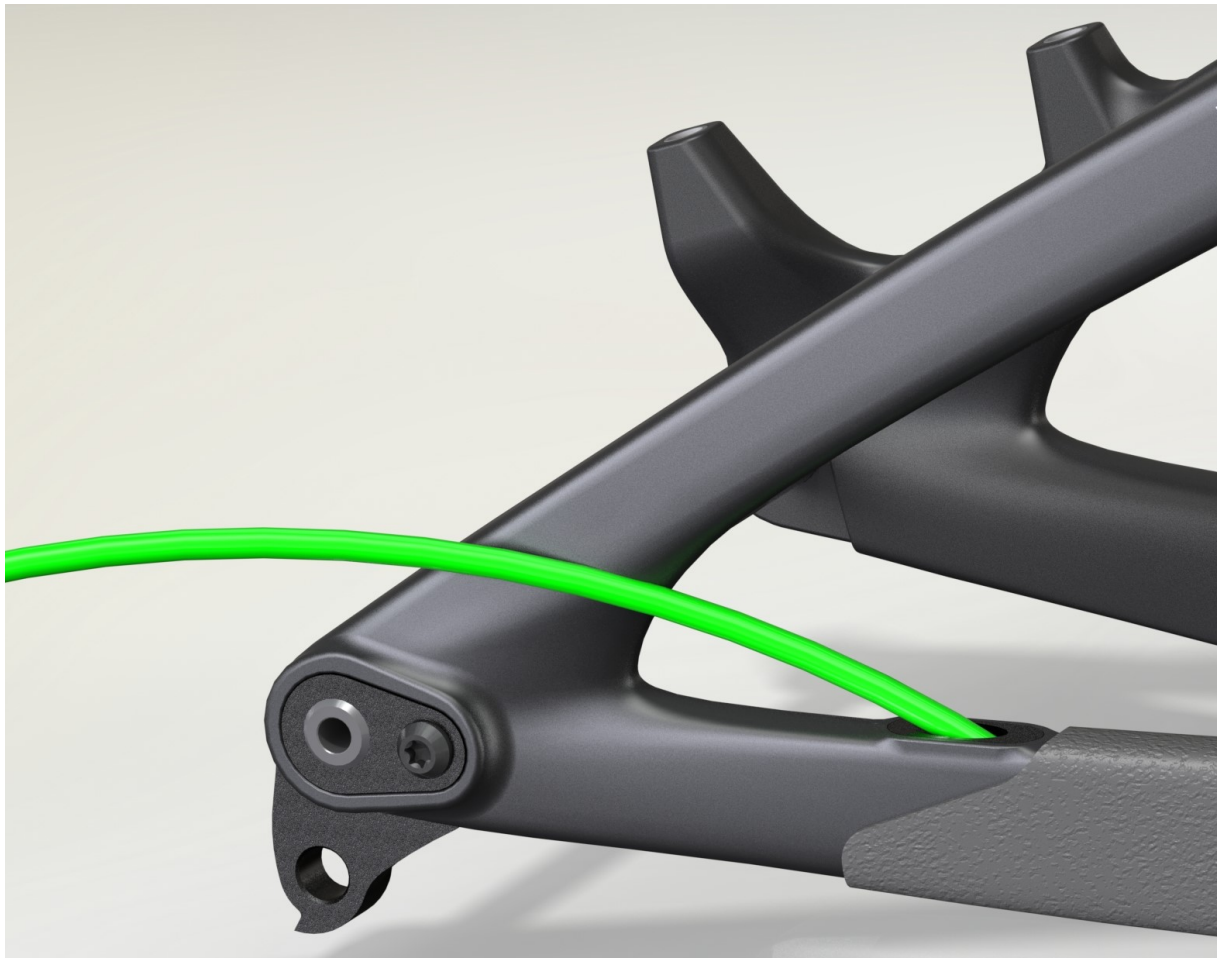

2. Slip the supplied p-clip on the cable housing between the rear triangle and front triangle. Do not install the p-clip to the frame at this time:

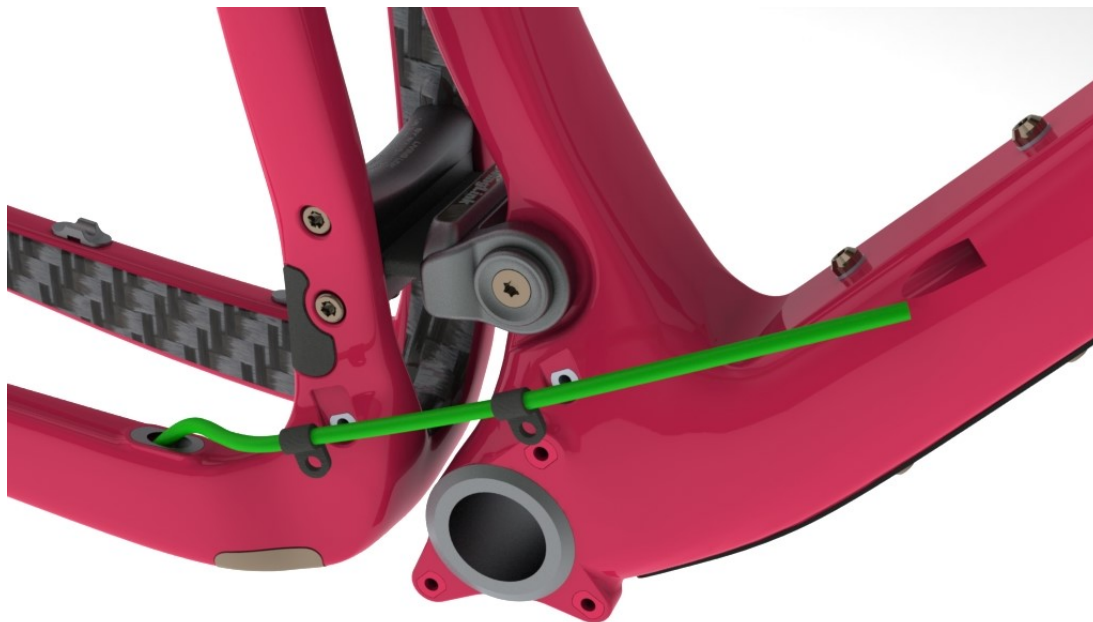

3. Feed the cable housing into the port on the drive side of the down tube. It will emerge from the port on the non-drive side of the head tube:

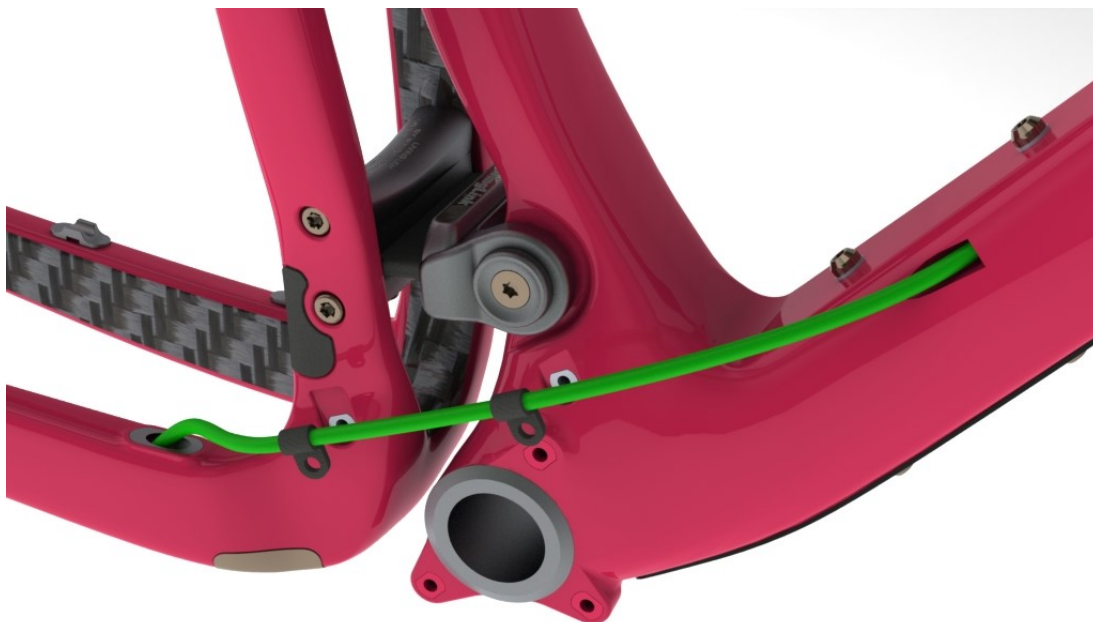



4. Feed the cable housing through the headset until desired length is reached. Then secure p-clips to the frame as shown below.

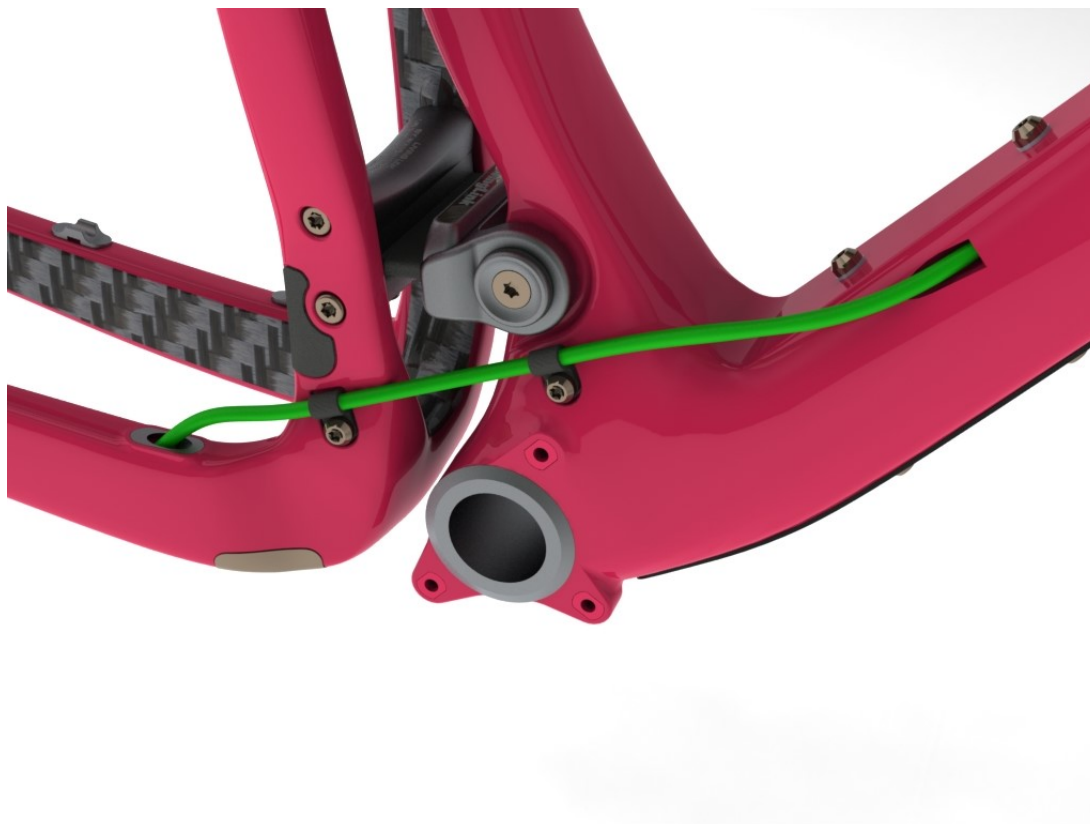

## E. Bottom Bracket Installation

### **IMPORTANT:**

**If using an internal dropper seatpost cable/hose, install the seatpost cable/hose before installing the bottom bracket assembly**

1. Ensure that the bottom bracket shell threads are clean, and that any internal seatpost cable/hose has already been routed.
2. Follow the bottom bracket manufacturer's requirements for internal dust sleeve and cup spacer orientations if required. Take care to observe the left/right orientation of each cup. The right/drive side cup is reverse threaded. Screw the bottom bracket cups in by hand.
3. Using the bottom bracket manufacturer's installation tools and an accurate torque wrench, torque the bottom bracket cups to the manufacturer's specification.



# Maintenance

## Tools Required For Rear Triangle Removal:

- Hex wrenches / bits, sizes: 5mm, 6mm
- Torx wrenches / bits, sizes: T25, T30
- Open ended wrench. Size: 19mm
- 12-point socket or box end wrench. Size: 10mm
- Torque wrench
- Round drift punches, flat tip, 5-6mm diameter and 8-10mm diameter
- Hammer
- Isopropyl or denatured alcohol—90% or higher concentration
- Medium strength (blue) thread locking compound, such as Loctite 243 (blue)

### Strongly Recommended:

- Bit Ratchet, 6mm hex bit

## Tools Required For Pivot Bearing Replacement:

(In addition to the tools listed above)

- PVC, or other plastic tubes:
  - 27-30mm inner diameter, 45-55mm long
  - 23-25mm inner diameter, 25-30mm long
- An assortment of sockets and extensions for bearing removal, 20-22mm outer diameter for main pivot bearings, 13-14mm outer diameter for upper pivot bearings
- Arbor press or bench vise for bearing installation

For individual parts and a complete exploded assembly diagram, please see the last page of this manual.

# Leaf Spring Related Precautions

The Living Link leaf spring, and its associated hardware, which include the 9 T30 Torx fasteners, main pivot clevis, and silicone sleeve are to be treated as integral to the rear triangle of the frame.

## **Do not attempt to remove or modify the leaf spring!**

Doing so is likely to damage the leaf spring, hardware, and possibly the rear triangle itself. Any questions or concerns regarding the leaf spring should be directed to Spot:

[www.spotbrand.com](http://www.spotbrand.com)

[sales@spotbikes.com](mailto:sales@spotbikes.com)

303-278-3955

It is recommended to periodically check the torque on the 7 leaf spring mounting fasteners. This should be done approximately every 100 hours of ride time, or once per year, depending on which occurs sooner.

1. Fit your torque wrench with a T30 Torx bit and the shortest extension required to reach the fasteners.
2. Clamp the bicycle securely in a work stand and remove the rear wheel.
3. **Stuff a thick rag or towel between the upper link and the seat tube. The front part of the link swings downward– it is important to protect the seat tube in the event that the link over-rotates in the next step.**
4. Remove the front shock mount bolt and nut, and swing the shock upwards while very carefully compressing the rear suspension at the rear dropout area. The leaf spring will initially resist compression, but once past mid travel, it will tend to pull the rear swingarm upward. Let the suspension come to rest in the upward position to gain access to the leaf spring mounting screws.
5. Turning the torque wrench clockwise (as seen looking at the head of the fastener) and verify that all 7 fasteners are at or above 12N-m (106in-lb).

# A. Rear Derailleur Hanger Removal/Replacement

1. Remove the rear wheel and the rear derailleur from the frame. It should not be necessary to remove the chain or cable/housing from the derailleur:

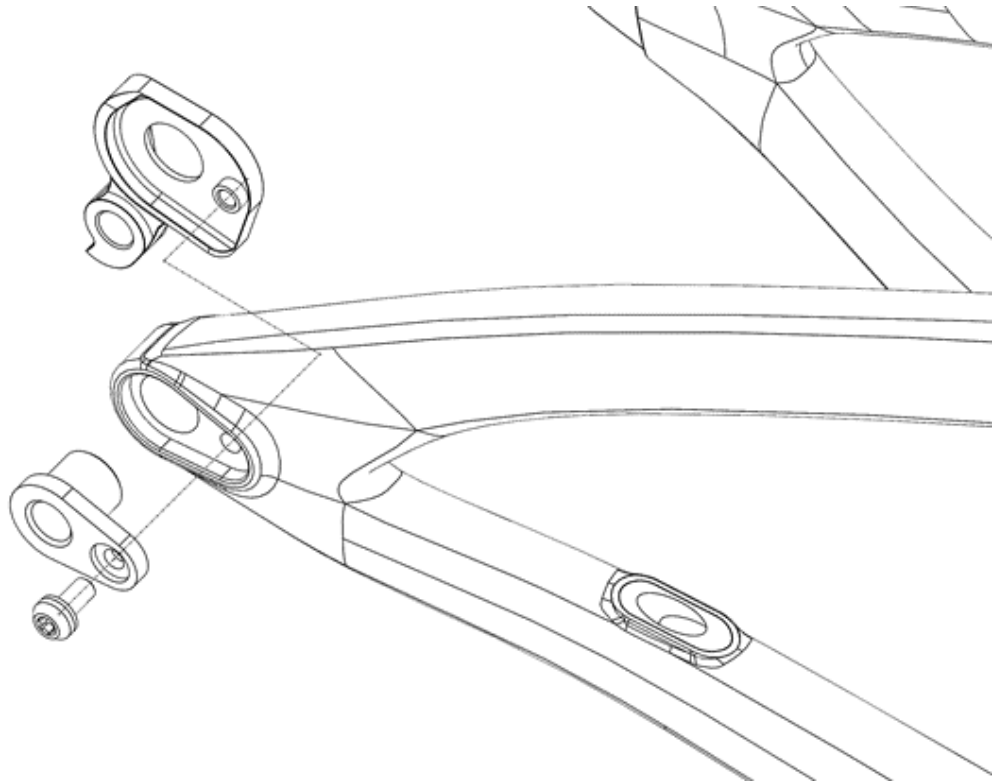

2. The derailleur hanger is removed using a T25 Torx tool on the external screw. When replacing the derailleur hanger, be sure to apply medium strength (blue) thread locking compound to the screw. Torque: 6.5Nm (57in-lb)

## B. Rear Shock Removal/Replacement

1. Using a T30 Torx tool (drive side) and a 10mm 12-point wrench or socket (non-drive side), remove the nut from the non-drive side of the front shock pivot pin.
2. Using a T30 Torx tool (drive side) and a T25 Torx tool (non-drive side), remove the screw from the non-drive side of the rear shock pivot pin:

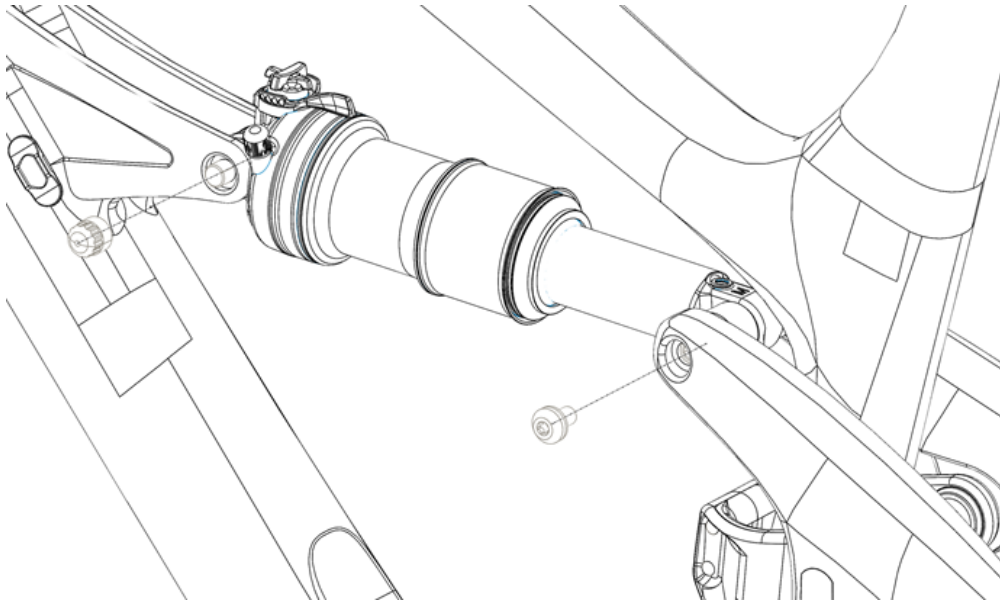

3. Remove both shock pivot pins. A gentle tap with a drift punch may be necessary to unseat them.
4. Carefully slide each end of the rear shock upward to free it from the frame:

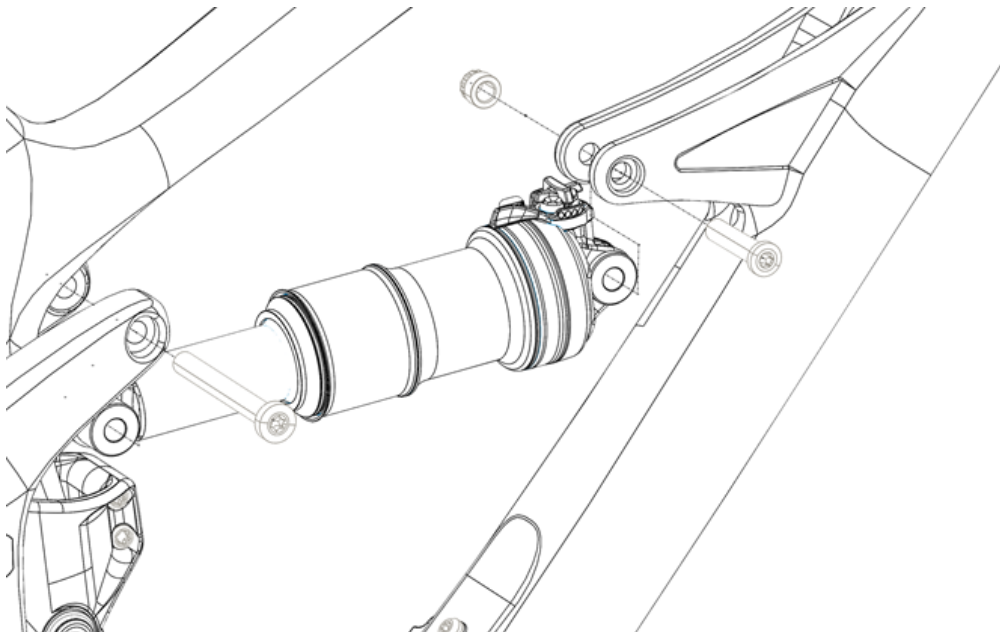

5. Installation is the reverse of removal. Pivot fastener torque: 8.5Nm (75in-lb)

## C. Rear Triangle Removal

1. Using a T30 Torx tool, remove the screw, drive side pivot cap, and o-ring:

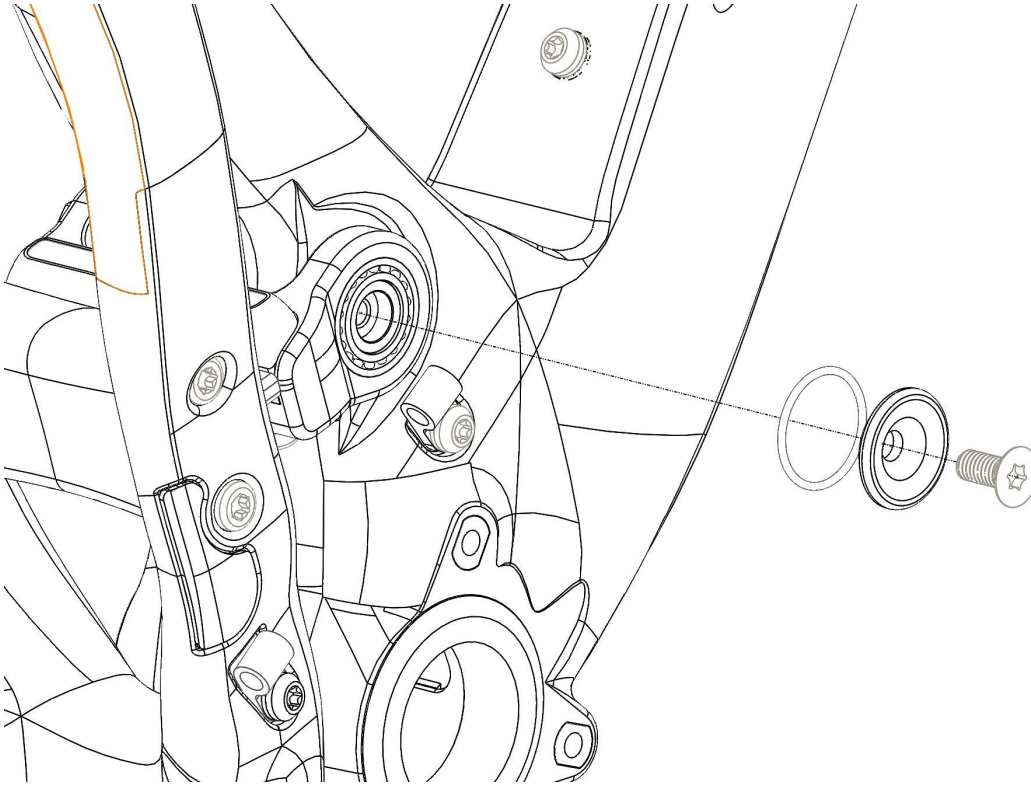

2. Using a 19mm open end wrench, remove the non-drive side pivot nut and o-ring:

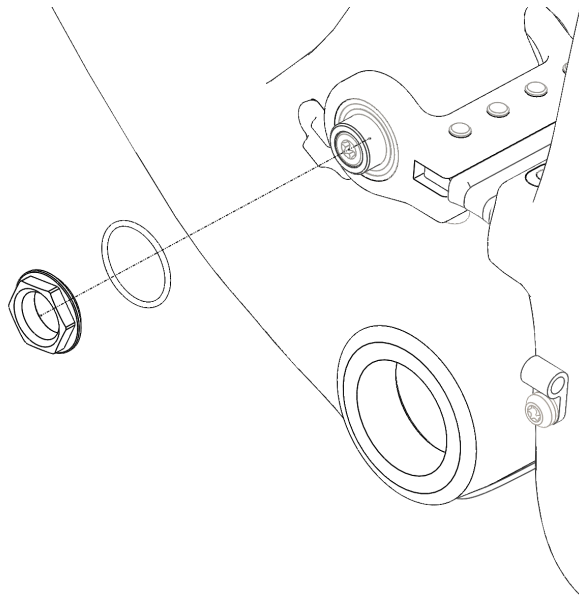

- Using a T30 Torx tool, loosen the center screw until the head stands 10mm above the surface of the pivot axle:

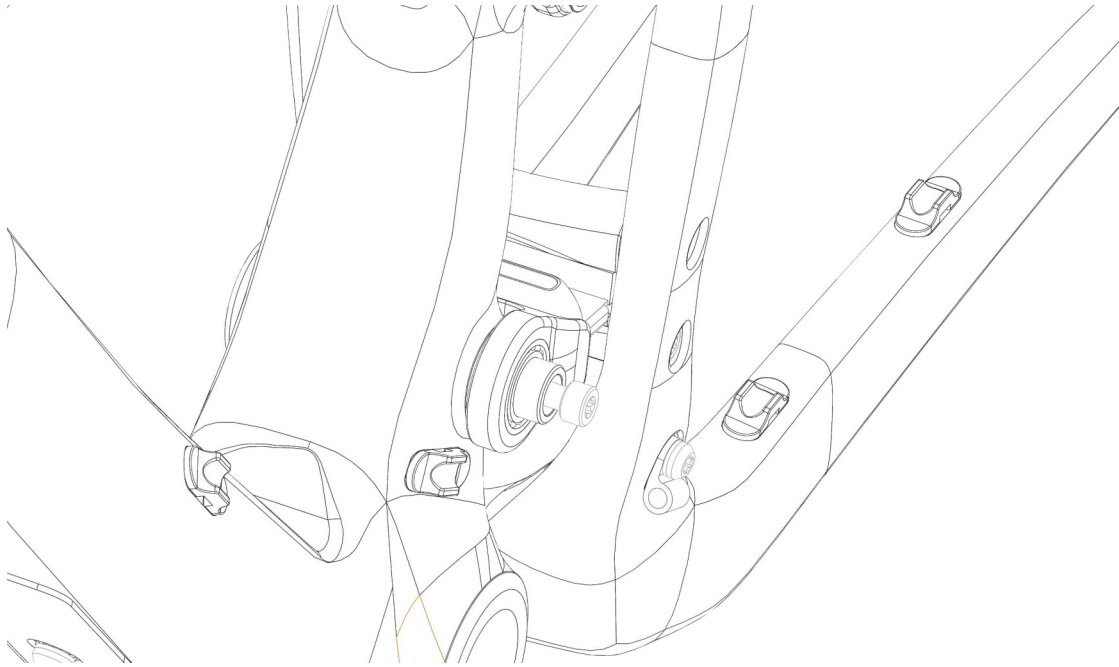

- Sharply strike the head of the center screw with a hammer. A drift punch can be used here to improve hammer accuracy. This will unseat the pivot axle on the drive side from its taper. Remove the center screw and drive side pivot axle:

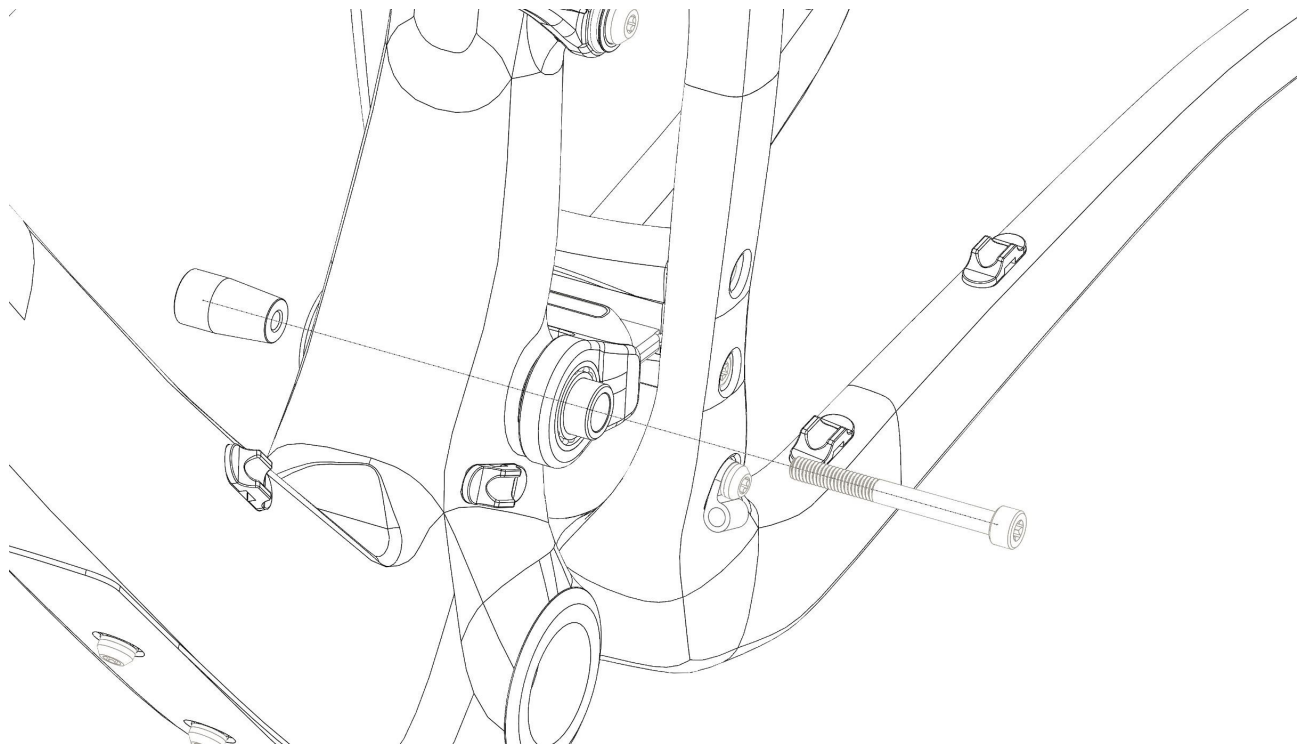

5. Insert an  $\varnothing 8-10$ mm drift punch into the main pivot bore from where the drive side pivot axle was removed. Ensure firm, even contact with the inner face of the non-drive side pivot axle. Strike the drift punch sharply with a hammer to unseat the non-drive side pivot axle:

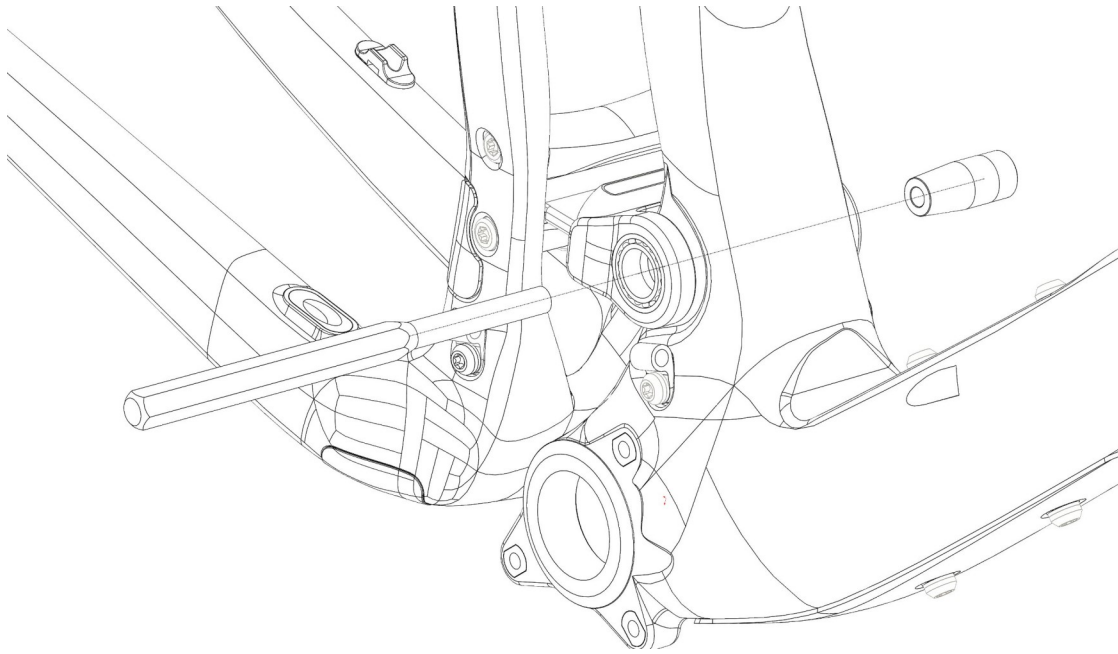

6. With the rear shock assembly removed from the frame, the rear triangle is now able to swing upward away from the front triangle. Place a hand under the main pivot yoke while slowly swinging the rear triangle up and rearward to catch the inner pivot washers and o-rings:

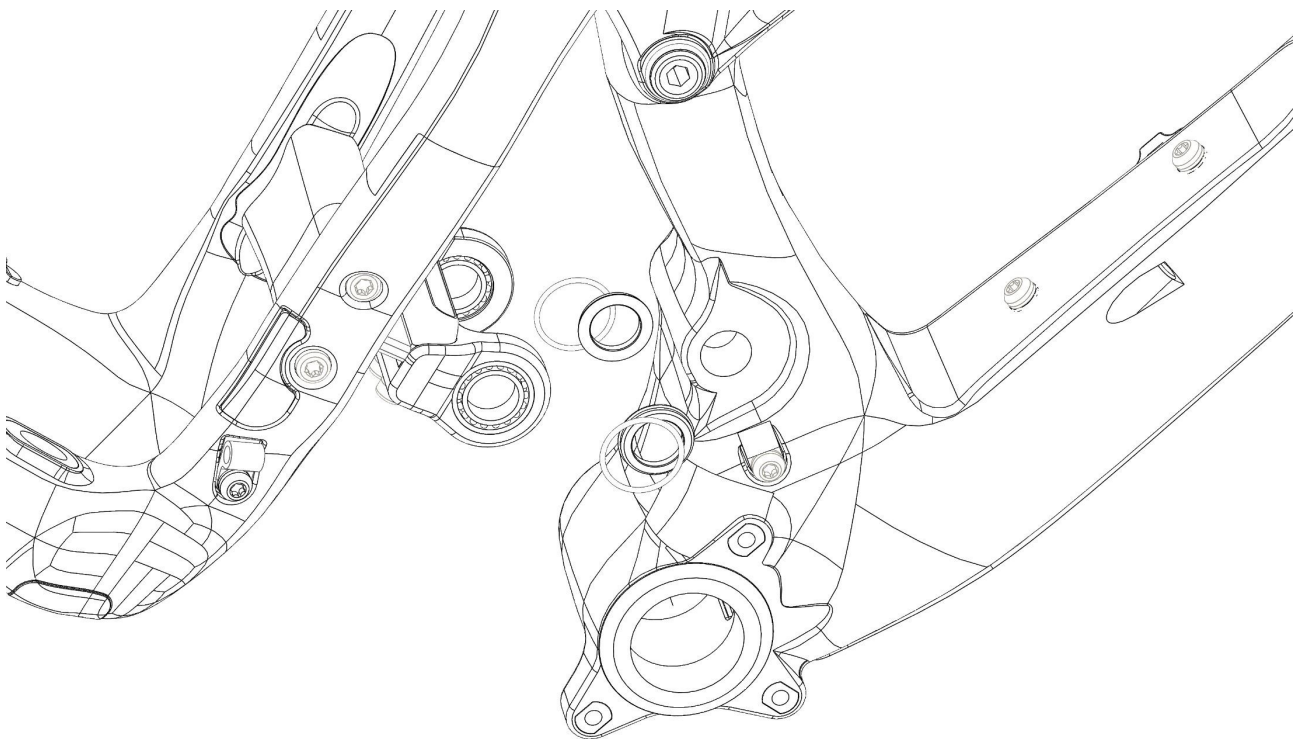

7. Remove the upper pivot bolt from inside of each shock stay at the upper link using a 6mm allen wrench, or better yet, a bit ratchet with a 6mm hex bit. The o-rings will come off with the upper pivot bolts:

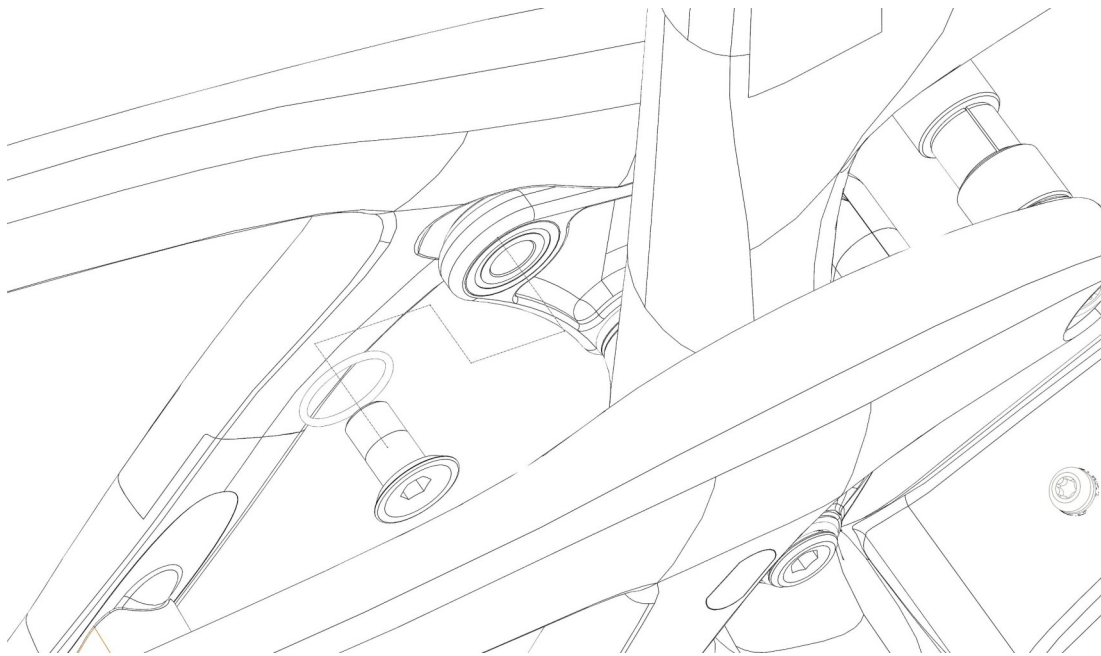

8. Once the upper pivot bolts are removed, the rear triangle assembly can be separated from the frame. Place a hand under the upper link while pulling the rear triangle rearward to catch the inner washers and o-rings from the upper link:

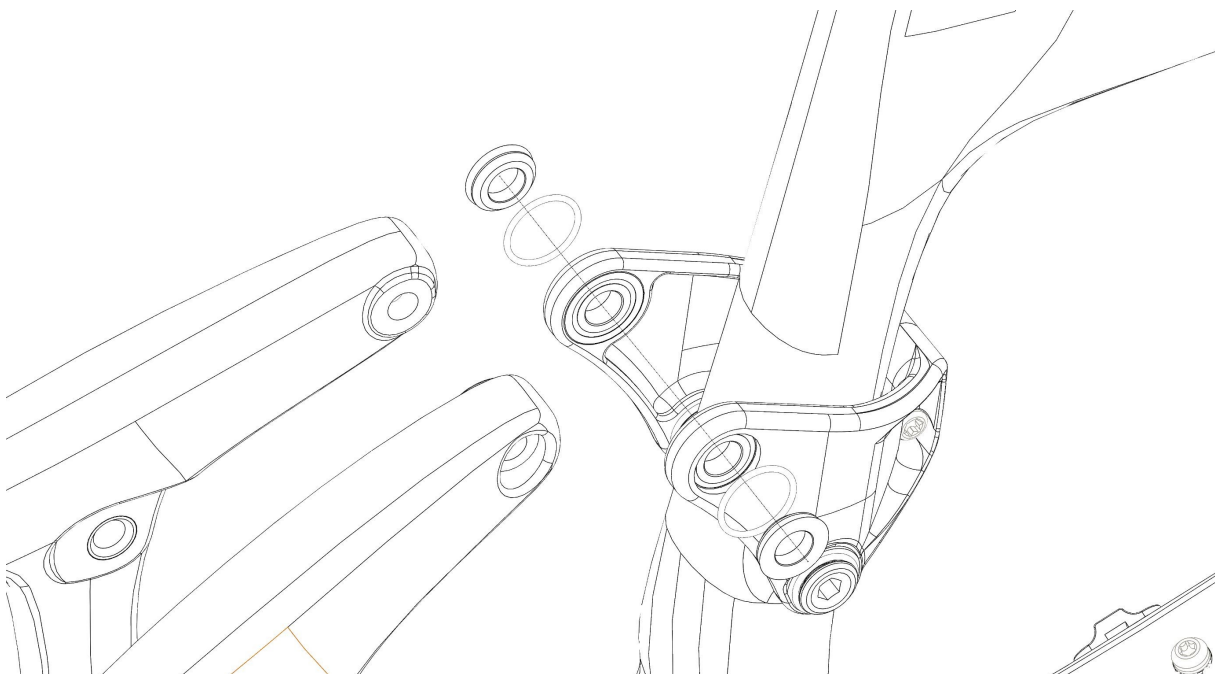



## D. Upper Link Removal

1. Using a T25 torx tool and a 6mm hex tool, remove the screw, o-rings, and link axle from the upper link assembly:

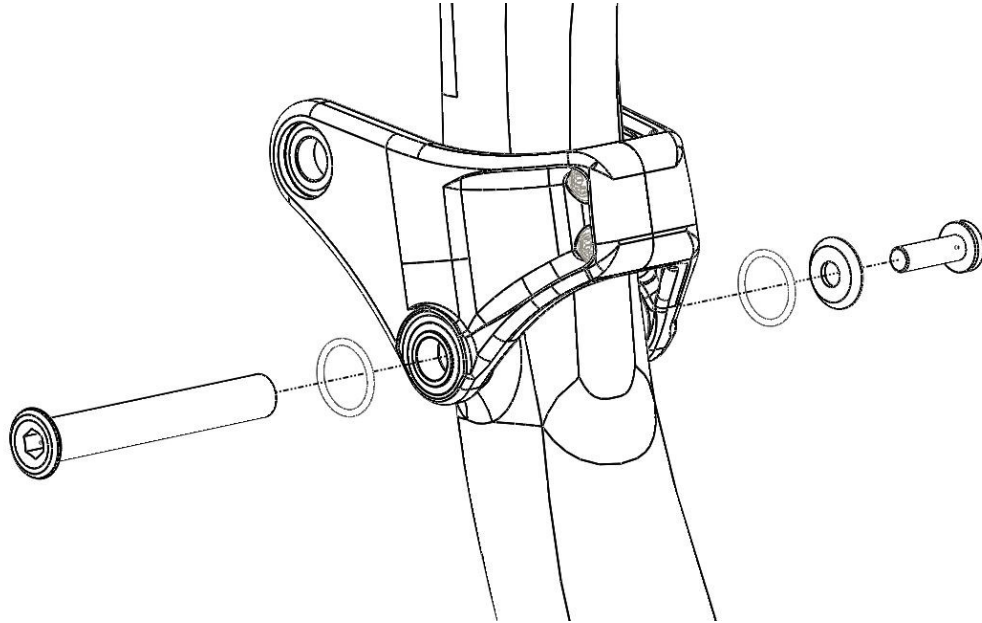

2. Gently slide the upper link assembly forward, keep a hand beneath the link assembly to catch the inner washers and o-rings:

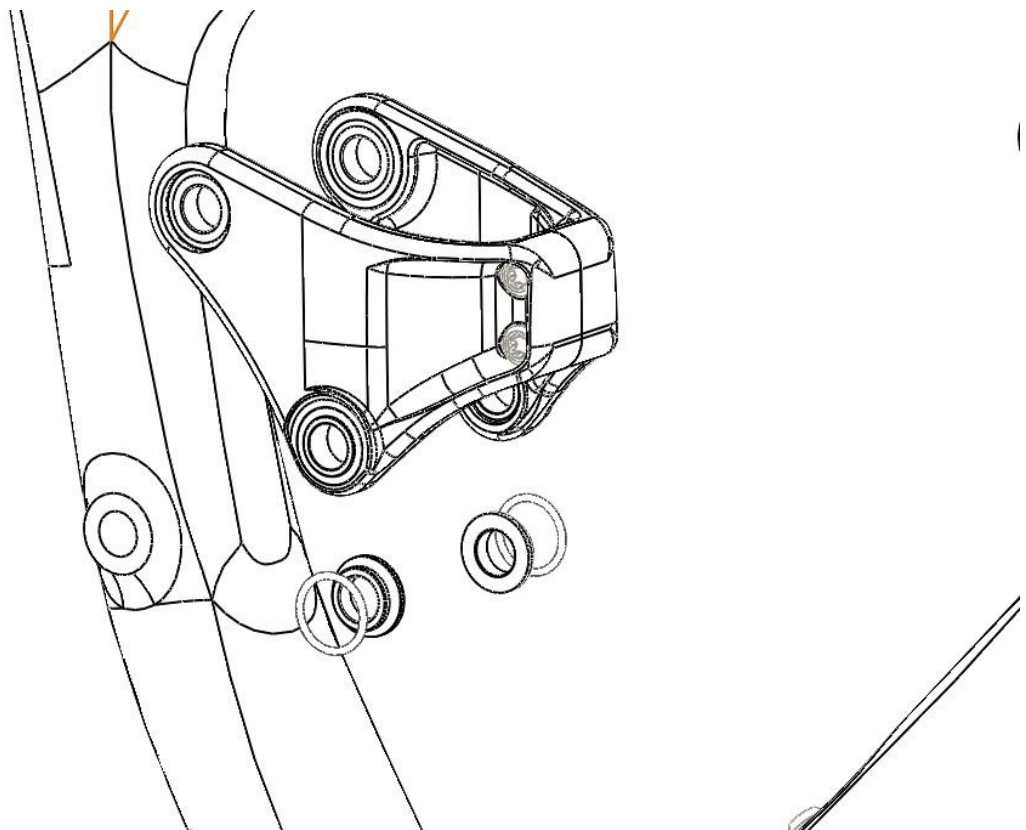

## E. Upper Link Disassembly

1. Replacing the upper link pivot bearings is facilitated by disassembling the upper link. Use a T30 torx tool to remove the two screws and separate the link halves:

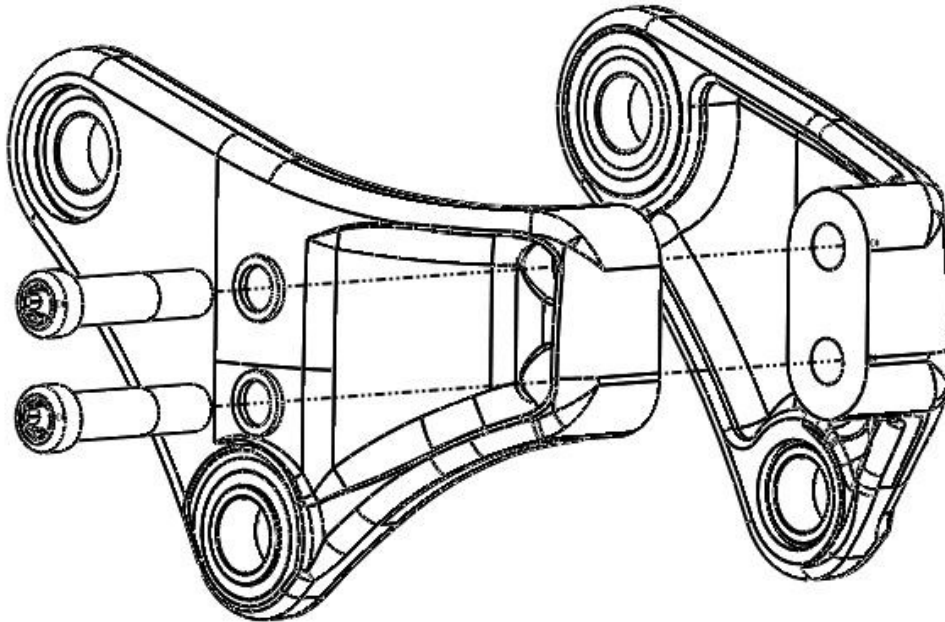

## F. Main Pivot Bearing Replacement

1. Set the rear triangle assembly on one side, on a work bench with a protective cloth to prevent scratching the frame finish. Support the pivot yoke as shown by your 27-30mm ID plastic tube. Combine your 20-22mm outer diameter socket with an extension, drift punch, or other implement as shown. Begin gently tapping with the hammer to push the bearing out of the frame and into the tube:

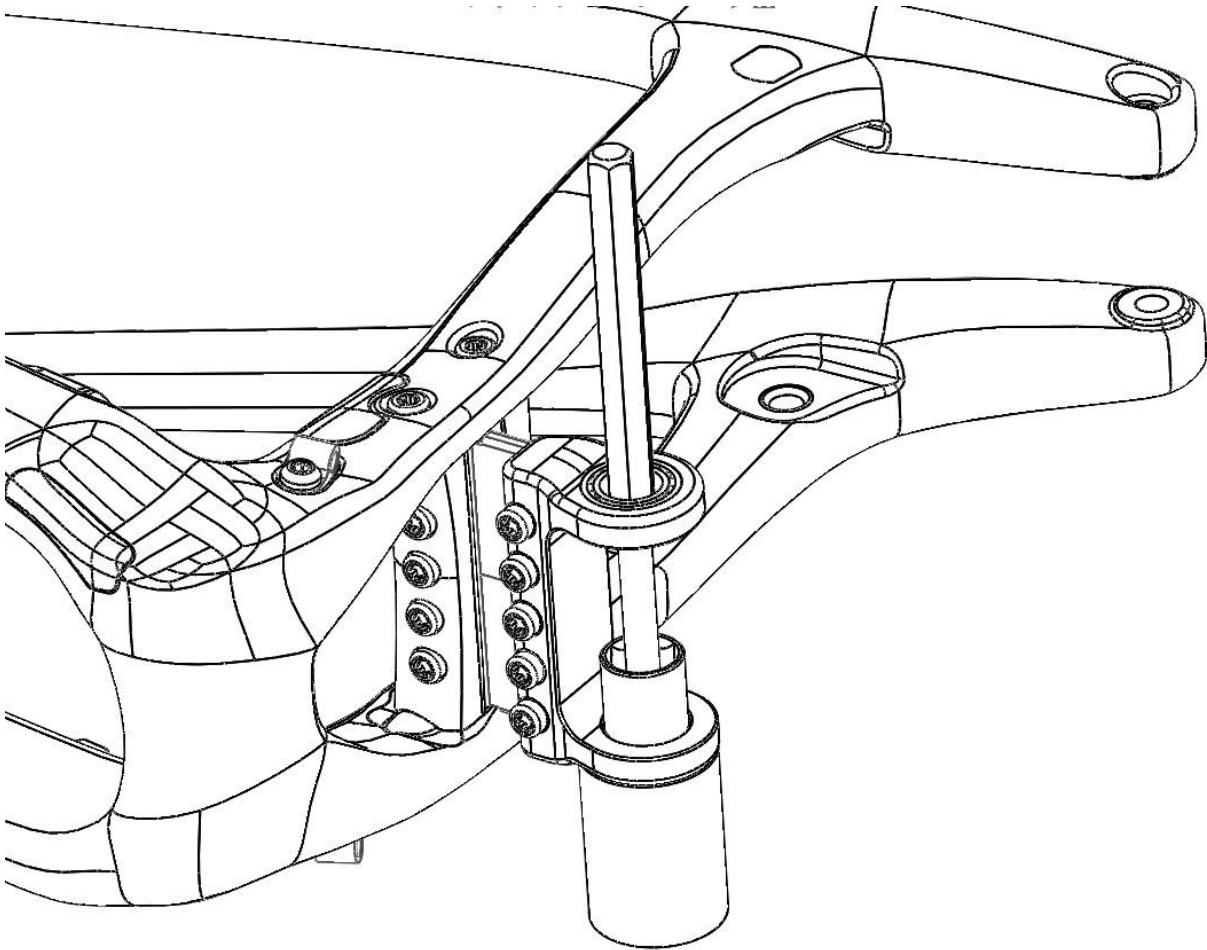

2. Remove the remaining main pivot bearing by flipping the rear triangle over and repeating.

1. Once the old bearings are removed, thoroughly clean the bearing bores in the pivot yoke with isopropyl alcohol. As with removal, there are a few different techniques that can be used to install the bearings. We recommend using an arbor press, but a bench vise, or even a piece of threaded rod with nuts and washers on either end will do the job. If using a press or a vise, It is ***absolutely necessary*** to support the yoke between the bearing hoops with a spacer. This can be another plastic tube, block of wood, or any non-marring solid piece that will support the hoops and keep them from bending as the bearings are pressed in. Press the bearings until they are flush with the outer surface of the yoke, taking care not to mar the finish of the yoke or frame.

**IMPORTANT: NEVER INSTALL BEARINGS USING A HAMMER OR ANY OTHER MEANS OF IMPACT!**

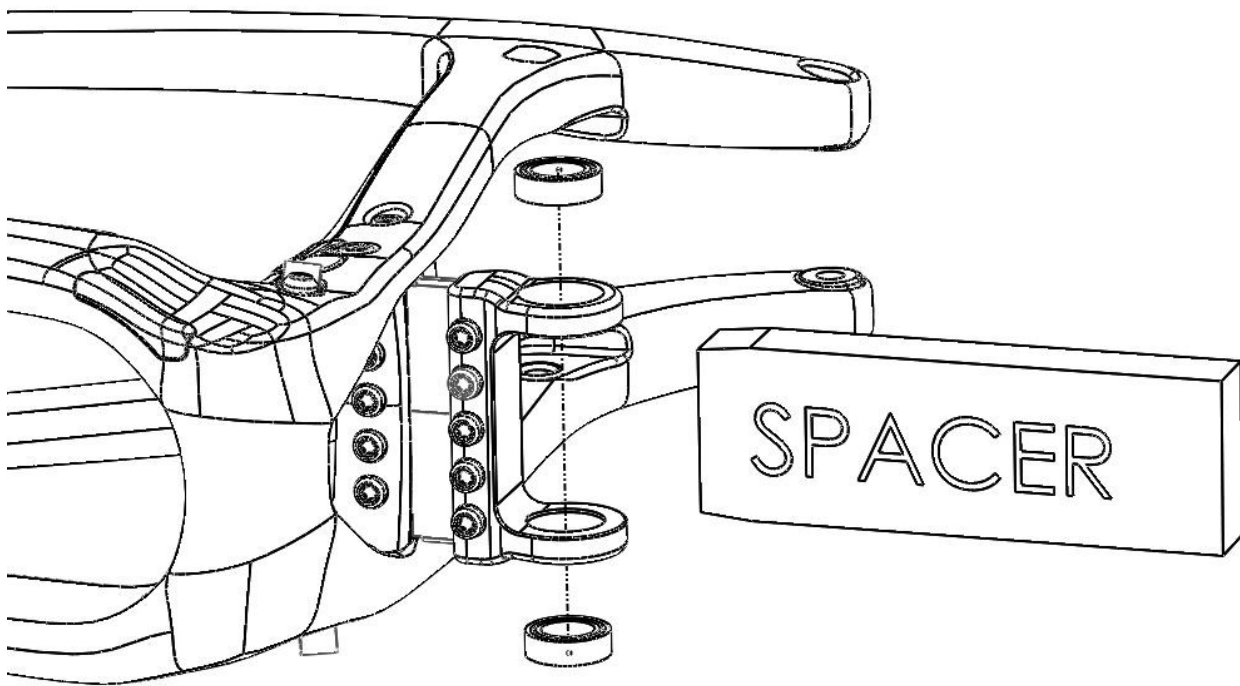

## G. Upper Link Bearing Replacement

1. The upper bearing in the link is removed by pressing it outboard, away from the centerline of the frame. Support the pivot yoke as shown by your 23-25mm ID plastic tube. Combine your 13-14mm outer diameter socket with an extension, drift punch, or other implement as shown. Begin gently tapping with the hammer to push the bearing out of the frame and into the tube:

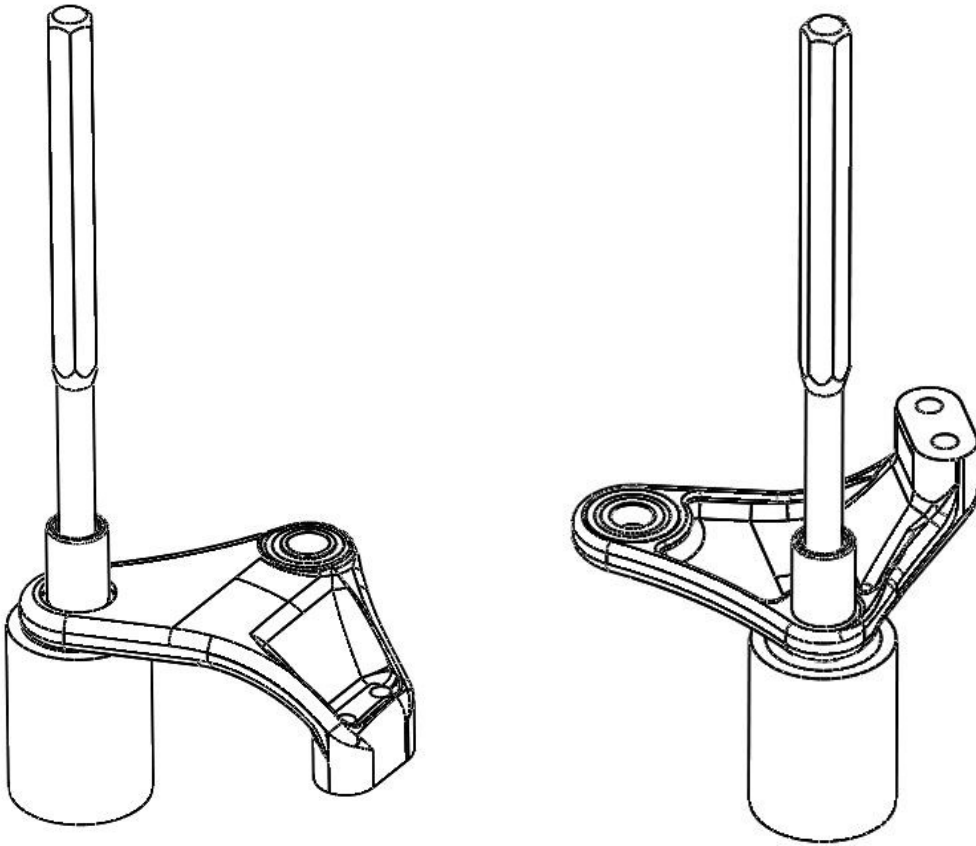

2. The lower bearing in the link is removed in the same manner, but is pressed outward, away from the centerline of the frame.

1. Once the old bearings are removed, thoroughly clean the bearing bores in the upper link halves with isopropyl alcohol. Similar to the main pivot bearings, there are a few different techniques that can be used for installation. We recommend using an arbor press, but a bench vise, or even a piece of threaded rod with nuts and washers on either end will do the job. Press the bearings until they reach the bottom of their bores, taking care not to mar the finish of the link:

**IMPORTANT: NEVER INSTALL BEARINGS USING A HAMMER OR ANY OTHER MEANS OF IMPACT!**

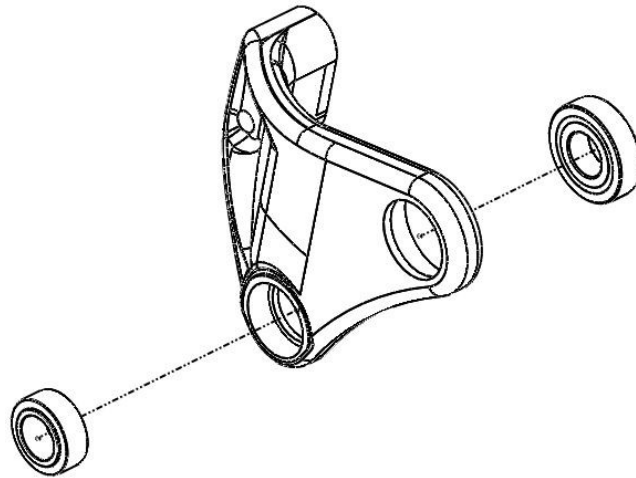

2. Reassemble the upper link using the two T30 Torx screws and medium strength (blue) thread locker. Torque to 8.5Nm (75in-lb):

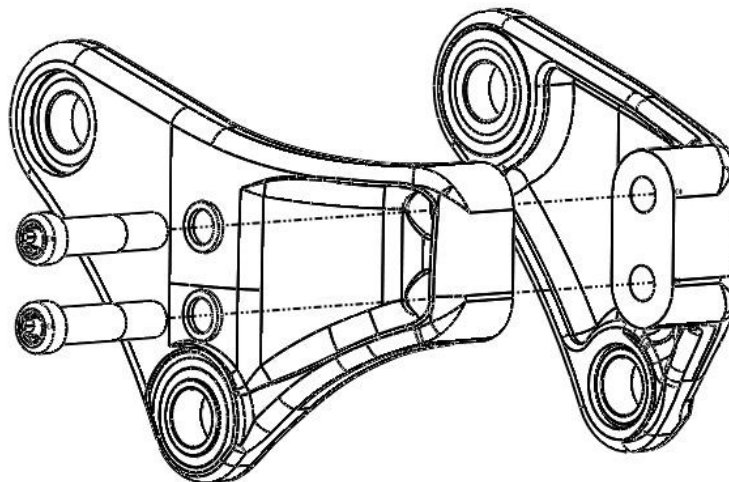

## H. Reinstalling the Upper Link

1. Prepare to reinstall the upper link by fitting new o-rings (1.5 X Ø13mm) to the washers to be installed between the link and the seat tube. The easiest way to do this is to lay the washer on a flat surface with the flat side down. Then push the o-ring down from the top until it sits in the installation groove:

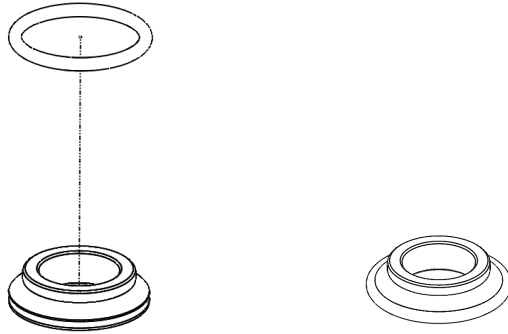

2. Insert the washers, with o-rings positioned in the installation grooves, into the inboard lower bearing recesses on the link assembly. A small application of grease can help to keep them in place for link installation:

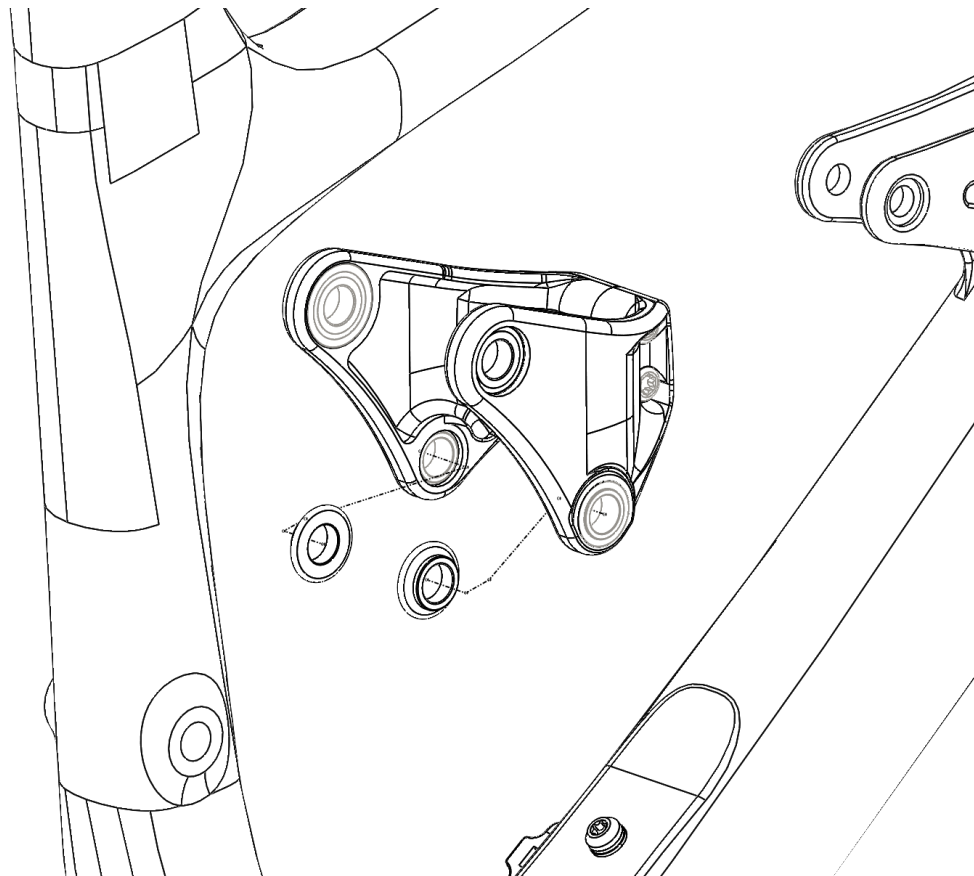

3. Being careful not to drop the washers/o-rings, and carefully slide the link assembly rearward onto the seat tube at the pivot boss:

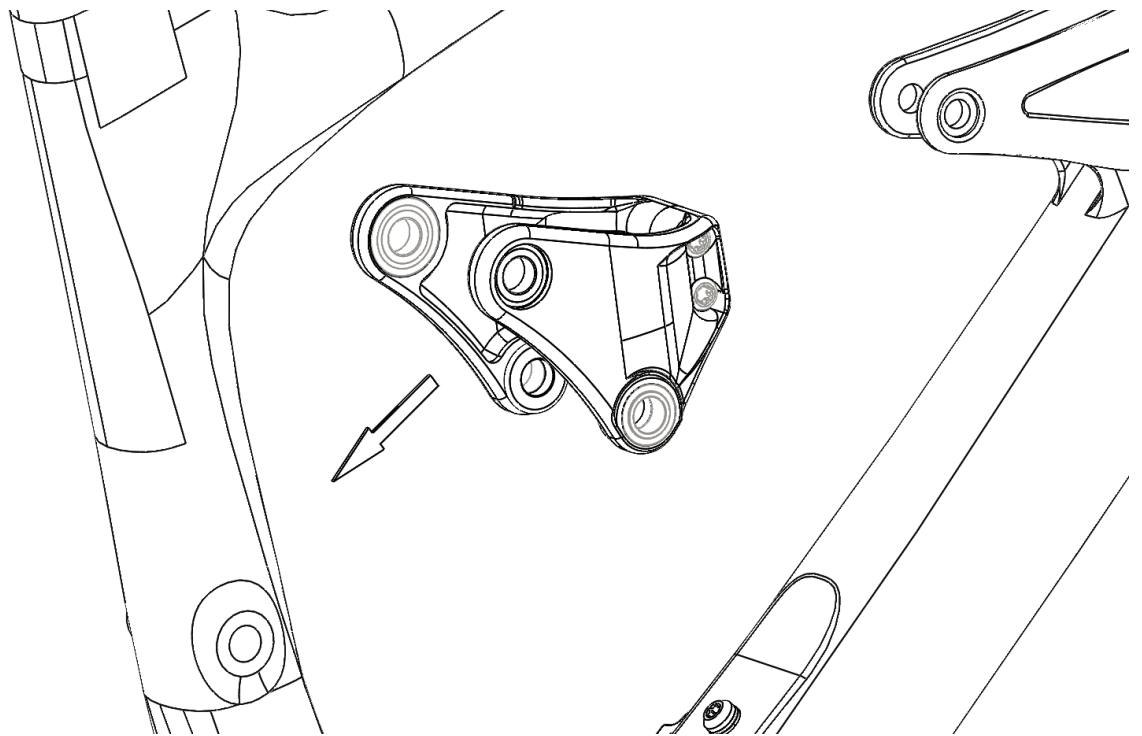

4. Reinstall the pivot axle, washer, and screw. Apply medium strength (blue) thread locker to the T25 Torx screw and torque to 8.5Nm (75in-lb):

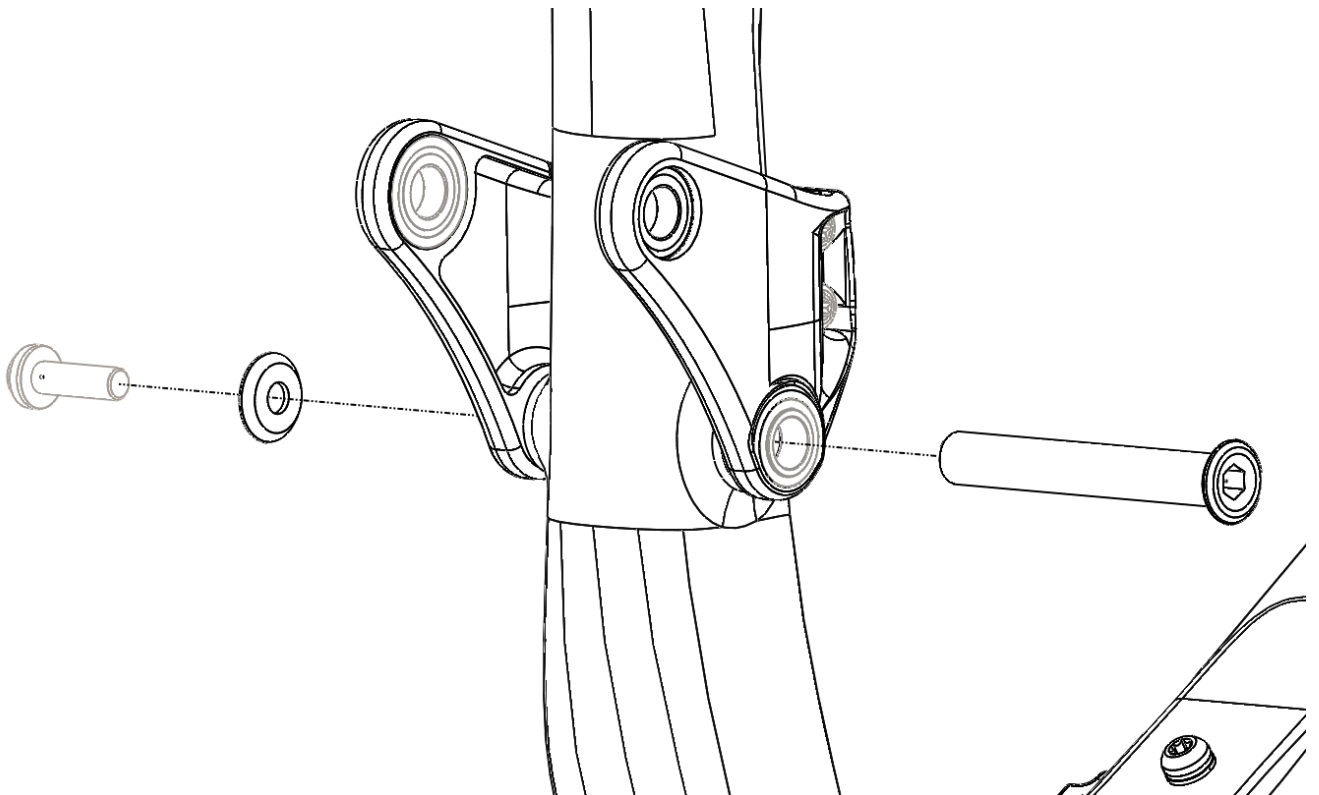



5. Using a pick, small screwdriver, or even a fingernail, move the inner o-rings from the installation position outward into the sealing position as shown here:

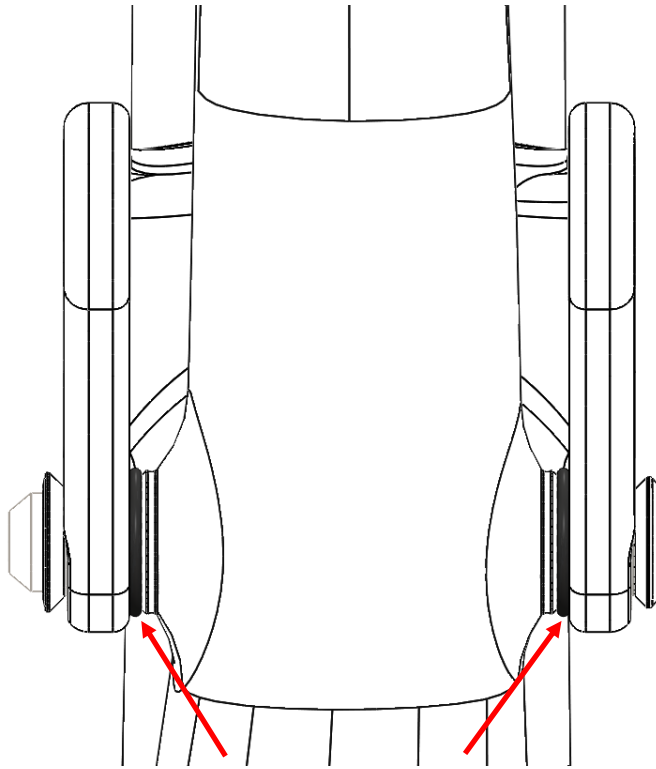

6. Install the outer pair of o-rings (1.5 X Ø13mm):

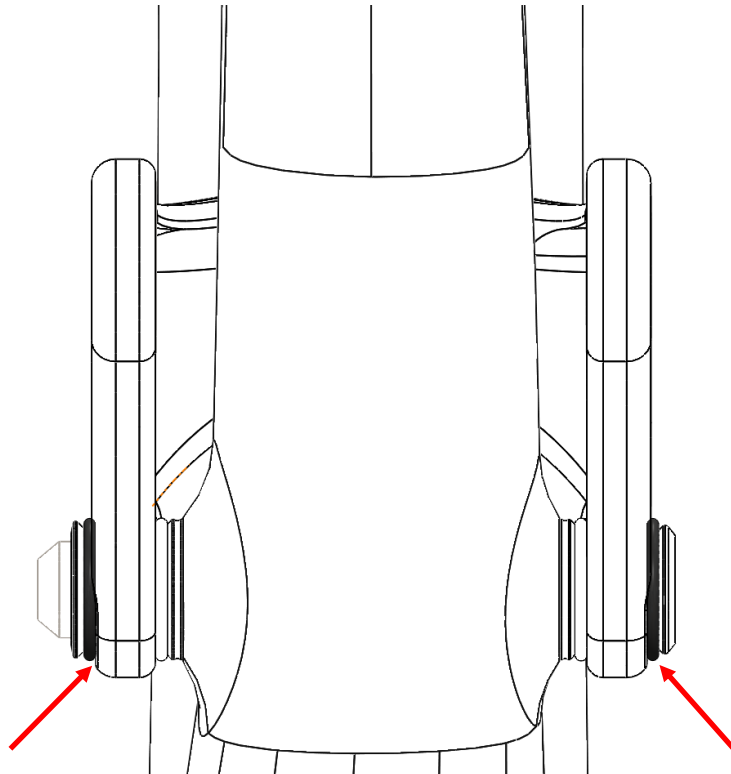

# I. Reinstalling the Rear Triangle

1. Stretch two upper o-rings (1.5 X Ø16mm) over the “ears” of the upper link to prepare for installation:

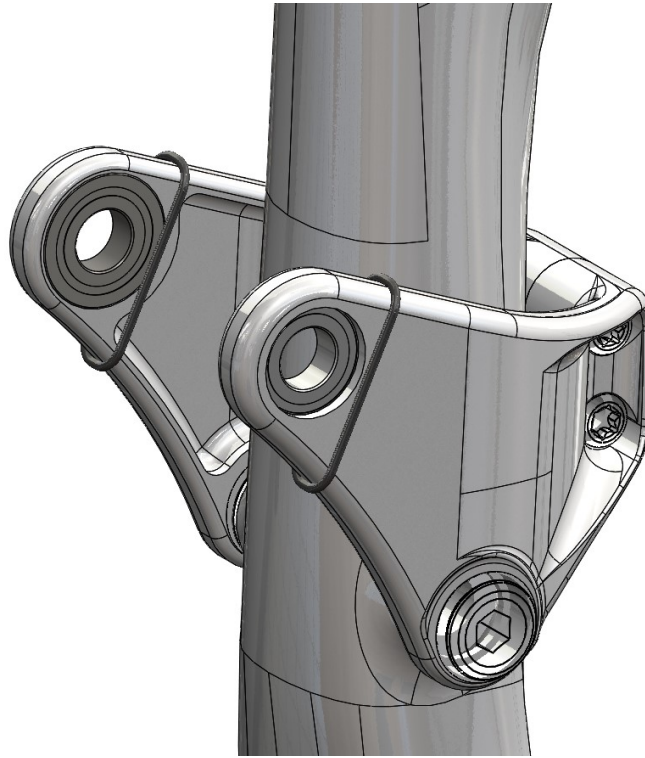

2. Install the upper washers, with the conical faces inboard– flat faces outboard, into the bearing recesses in the upper link. The o-rings will help hold the washers in position and vice versa. Again, a small dab of grease on each washer can help it stay in place for installation:

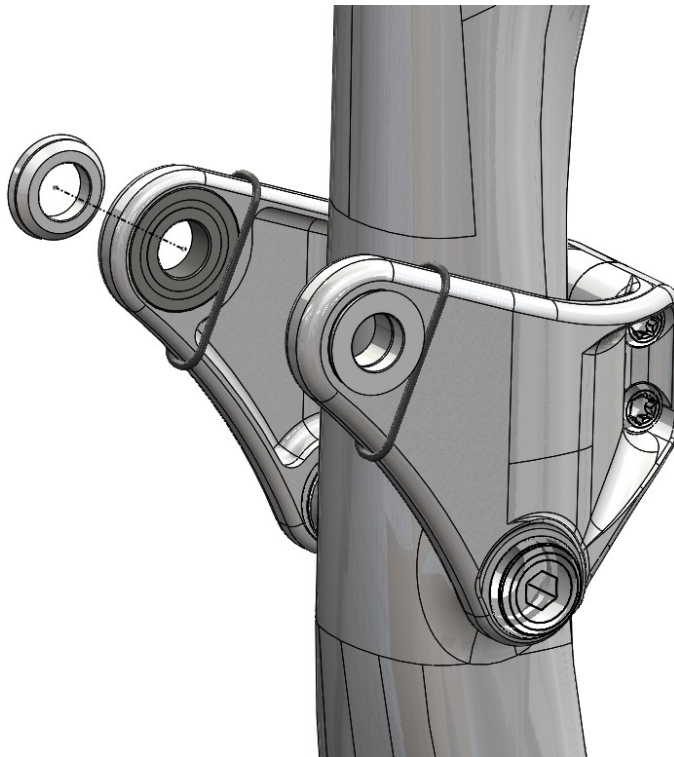

3. Slide the rear triangle assembly onto the upper pivot of the link:

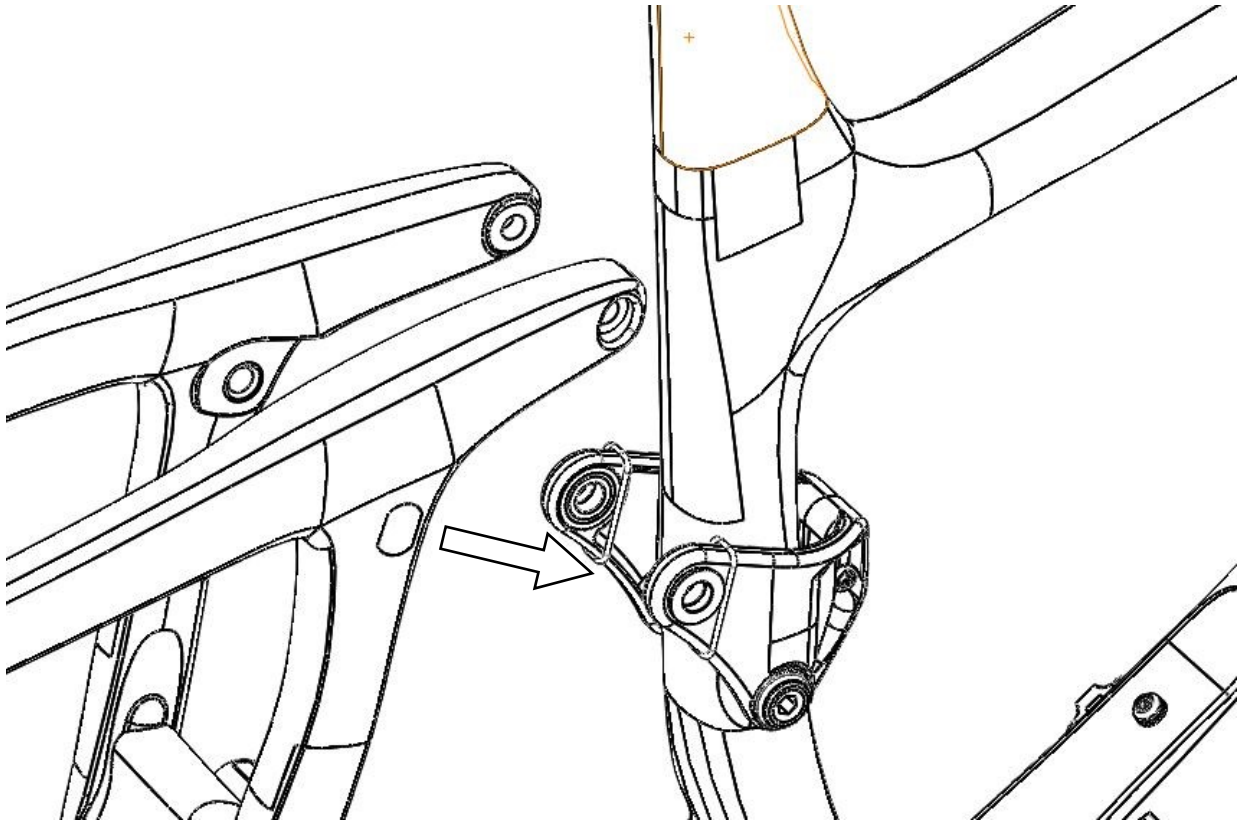

4. Install the upper pivot bolts with medium strength (blue) thread locker. A bit ratchet with 6mm bit is very handy here. Torque to 9Nm (80in-lb):

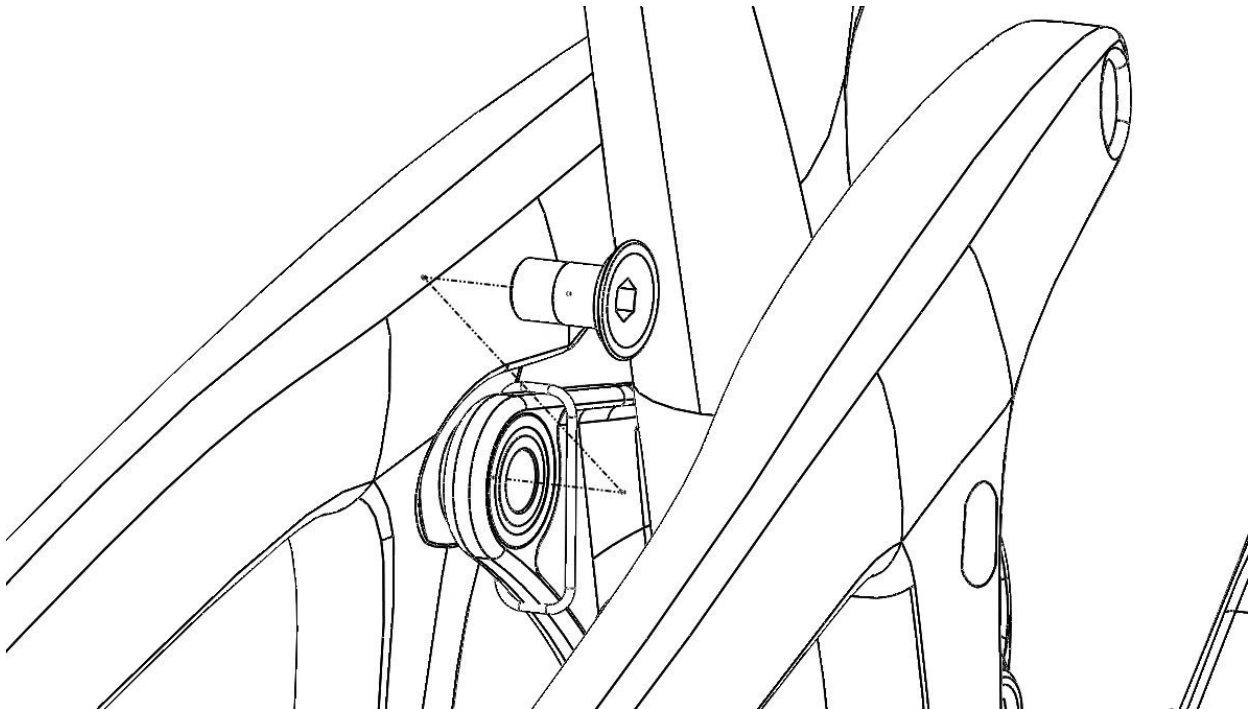

5. Pull the outboard o-rings over the “ears” of the link to set them into position between the link and the shock stays:

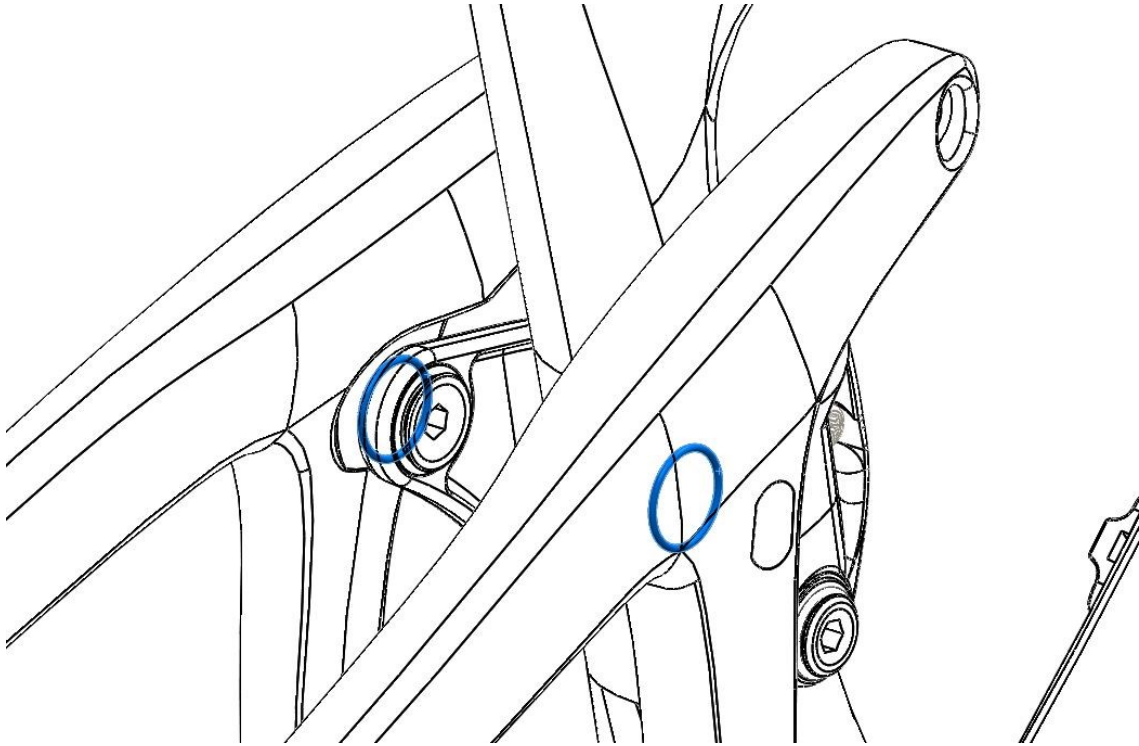

6. Install the inboard o-rings over the pivot bolts:

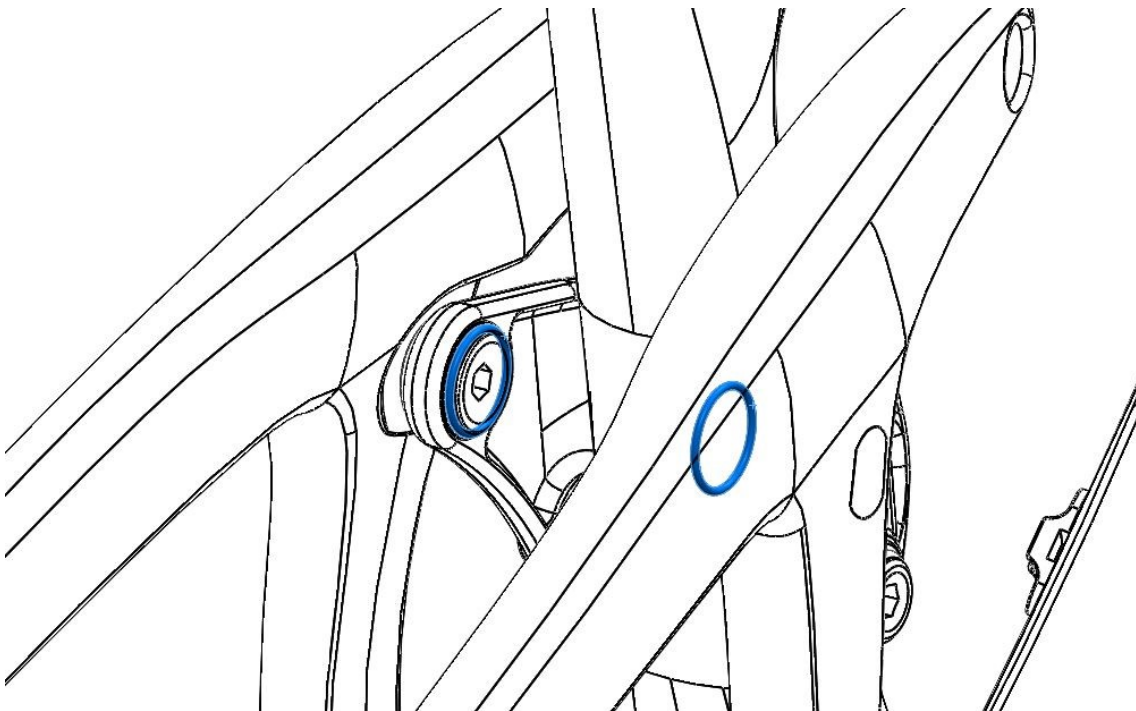

7. Stretch two lower o-rings (1.5 X Ø19mm) over the hoops of the main pivot bearings to prepare for installation:

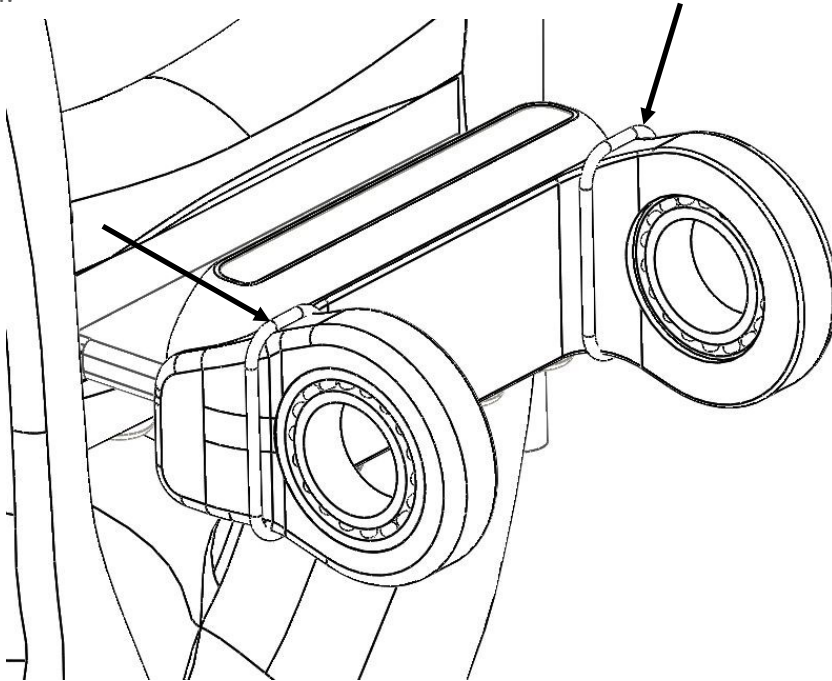

8. Install the inner washers, with the conical faces outboard– flat faces inboard, into the inboard bearing recesses in the main pivot clevis. The o-rings will help hold the washers in position and vice versa. A small dab of grease on each washer can help it stay in place for installation. Swing the rear triangle into place aligning the clevis to the main pivot:

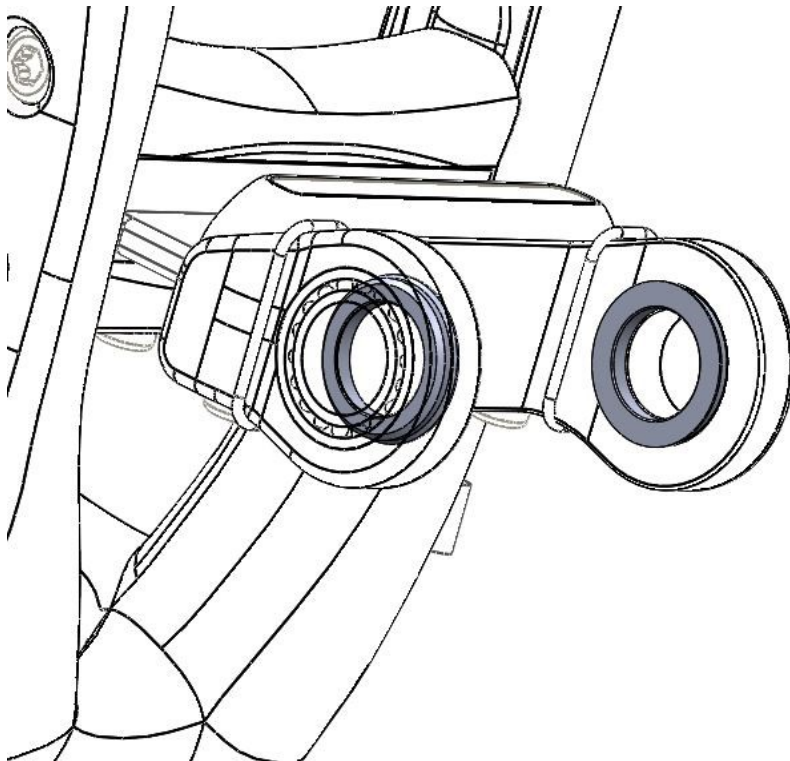



8. Clean the two conical main pivot axles with alcohol before inserting into their bores in the frame. The longer, externally threaded axle goes in the non-drive side, and the shorter, internally tapped axle goes into the drive side:

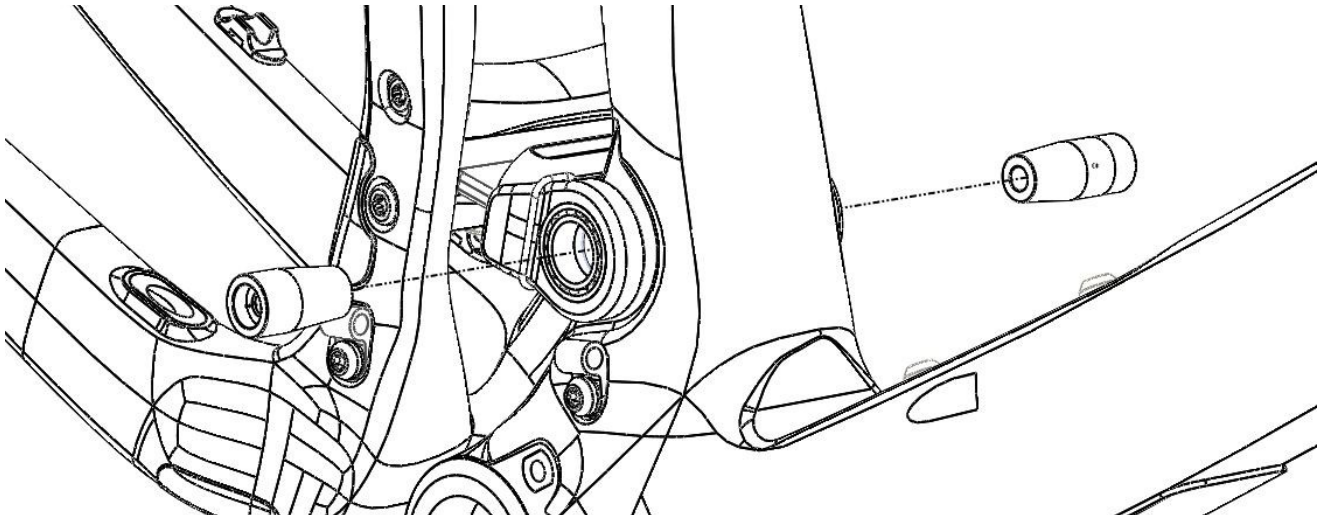

**IMPORTANT: DO NOT GREASE CONICAL SURFACES OF PIVOT AXLES OR BORES IN FRAME! GREASE CAN ALLOW TOO MUCH FORCE IN THE FRAME FOR THE SPECIFIED TORQUE VALUE AND DAMAGE THE FRAME!**

9. Install the main pivot screw (T30 X 45) and torque to 10Nm (98in-lb). It may be necessary to hold the drive side main pivot axle with a finger to keep it from turning. **Do not apply any thread locker:**

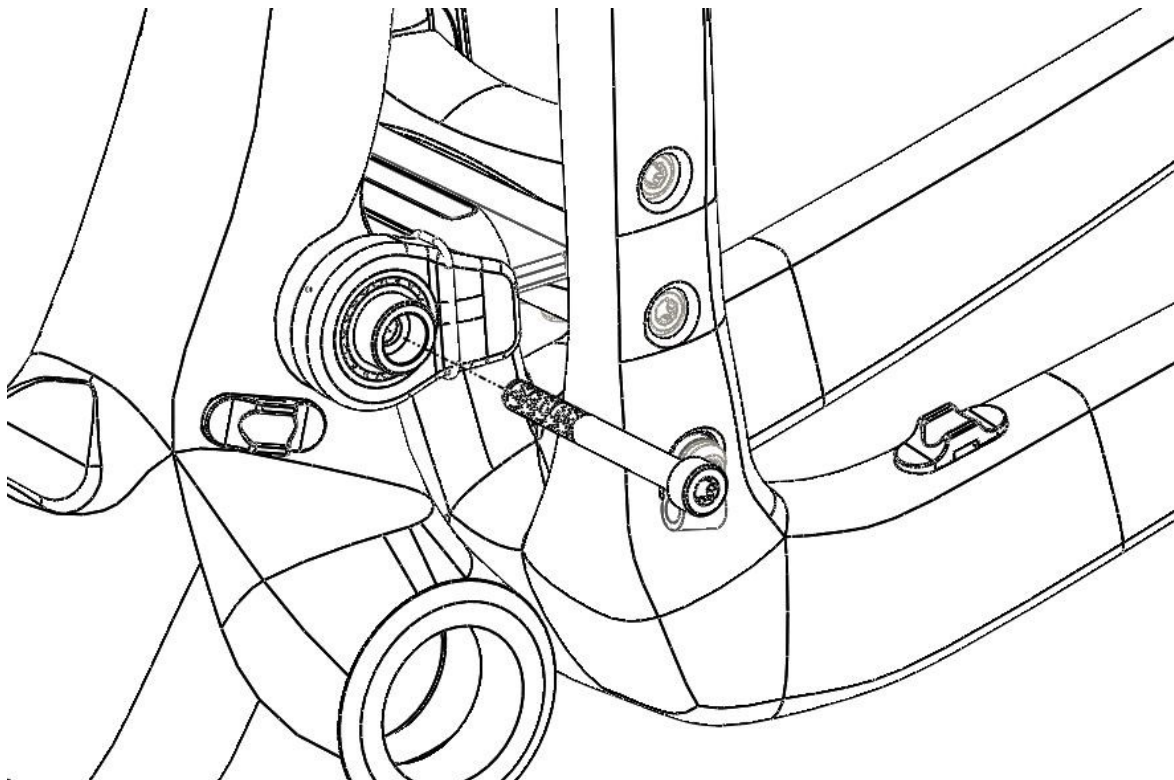

10. Pull the inboard o-rings into place between the pivot clevis and the frame:

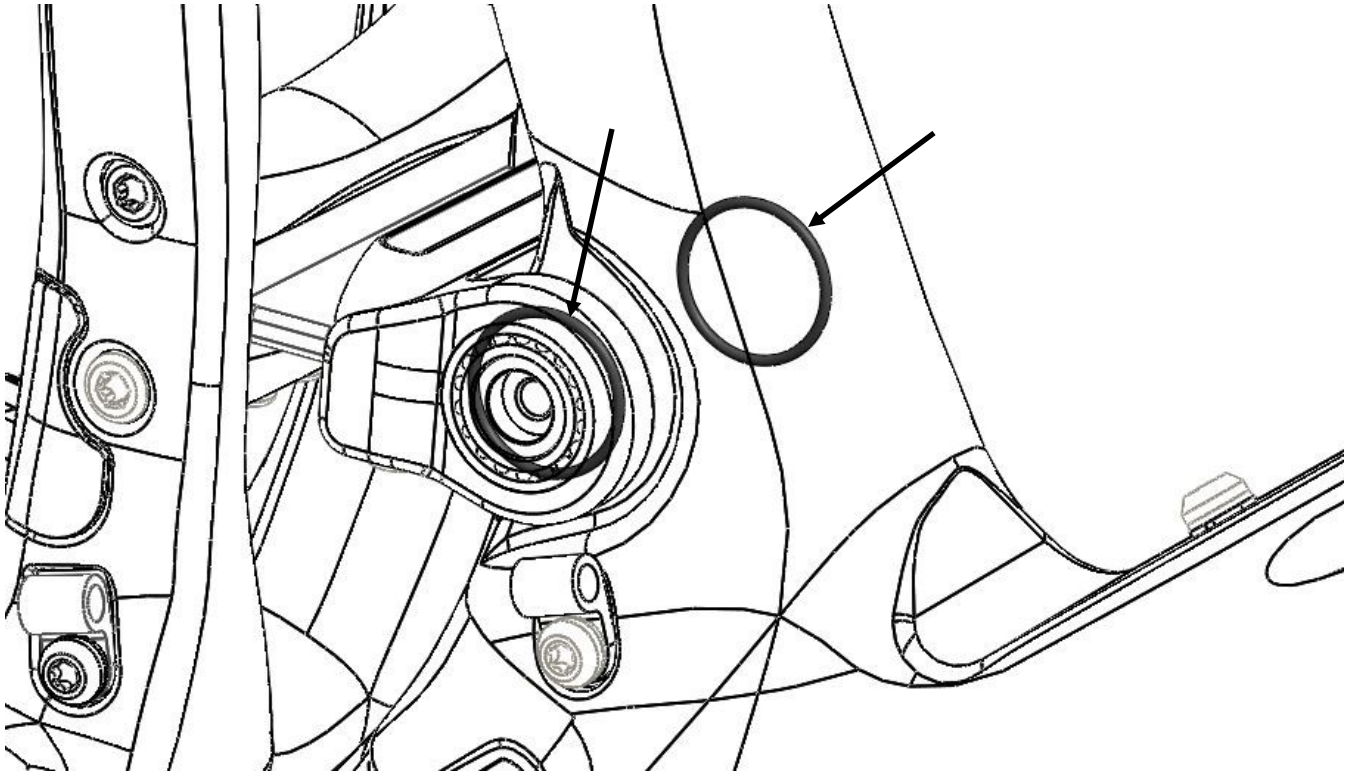

11. Install the outer nut (19mm hex) on the non-drive side and pivot cap (T30 screw) on the drive side. Apply fresh medium strength (blue) thread locker to the nut and screw for installation. Torque: 6.5Nm (57in-lb) both sides:

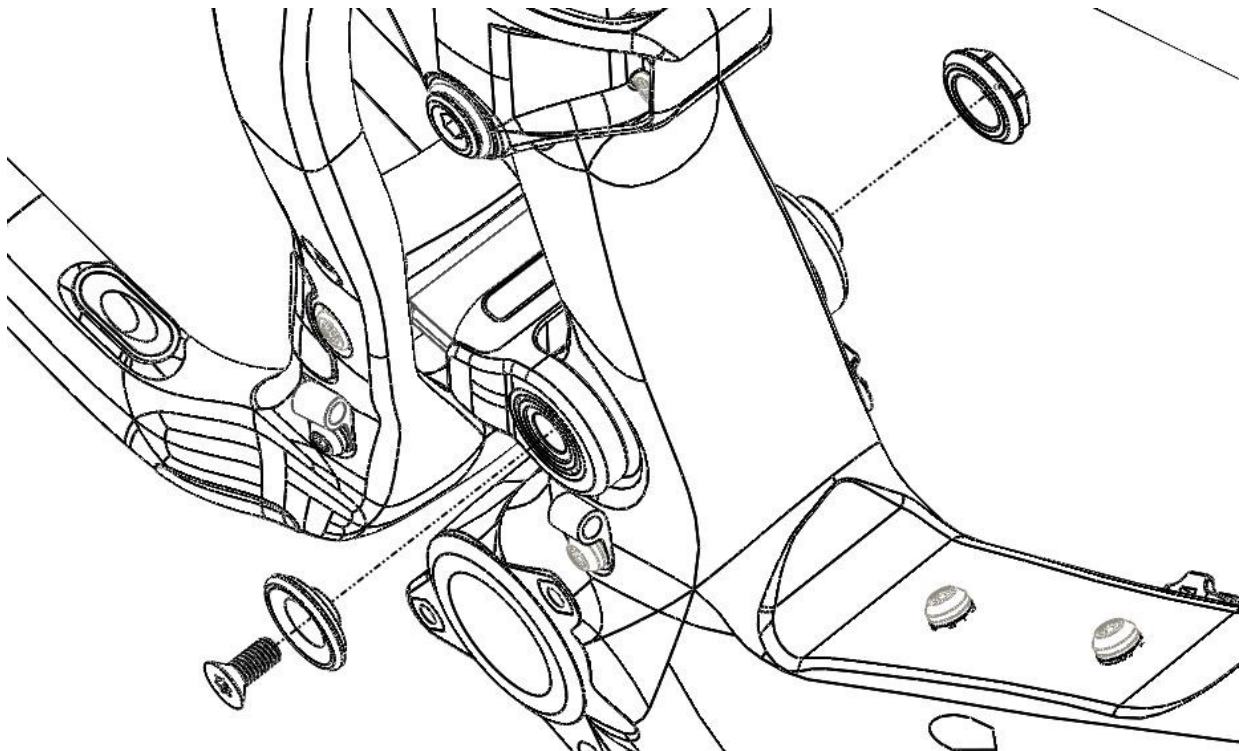

12. Install the outboard o-rings (1.5 X Ø19mm):

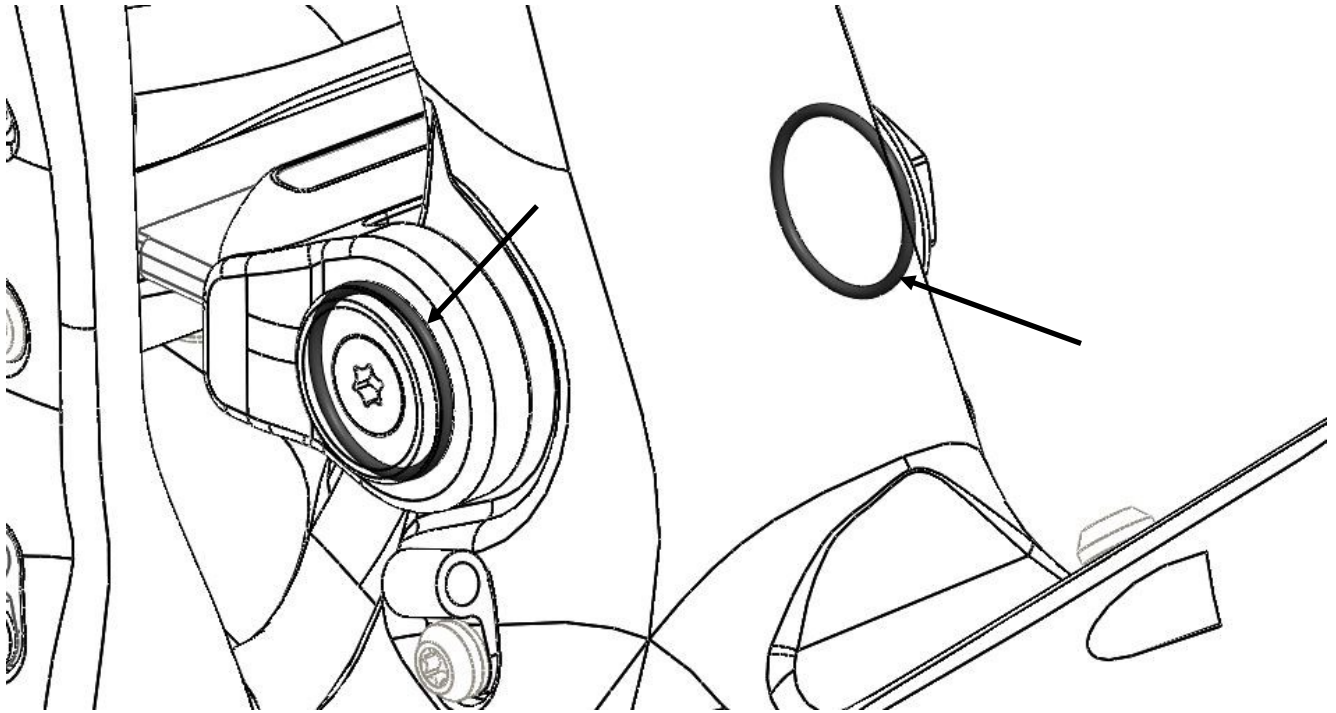

13. Install the shock unit. Torque fasteners to 8.5Nm (75in-lb):

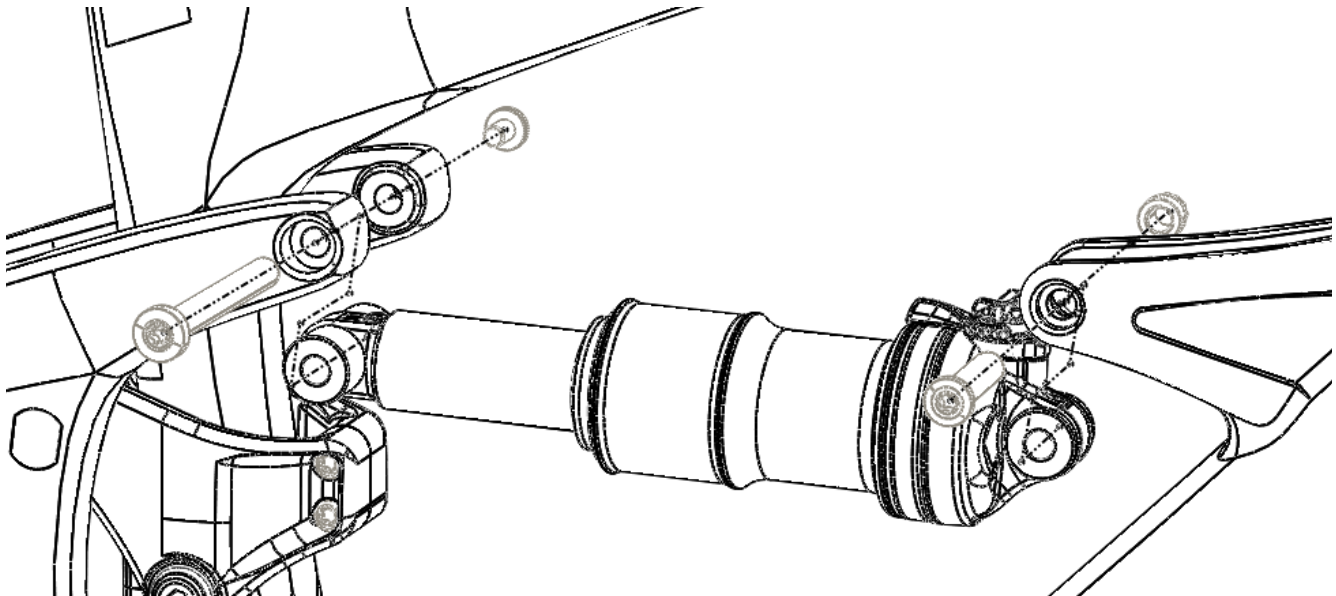



# Rollik 557 Frame Parts Reference

ITEM NO.	PARTNO	DESCRIPTION	ITEM NO.	PARTNO	DESCRIPTION
2	FS90022	SCREW, M6 X 25 T30	67	FS80012	WASHER, M6 HIGH COLLAR
3	FS90023	WASHER, 6mm	68	FS90048	SHOCK PIVOT NUT
5	FS80005	BEARING, MAIN PIVOT	72	FS80002	BEARING, ST PIVOT
9	FS80011	O-RING 1.5 X 19	73	FS90017	PIVOT CAP, ST
12	FS90009	RD HANGER	74	FS90014	PIVOT WASHER, UPPER
13	FS80000	SCREW, TORX, M5 X 20	75	FS80009	SCREW, TORX, M6 X 21
17	FS90010	AXLE NUT, MAXLE	76	FS90016	LINK AXLE
21	FS80006	SCREW, TORX, M5 X 13	77	FS90013	PIVOT BOLT, UPPER
30	FS80007	P-CLIP	78	FS90007	UPPER LINK HALF, DS
36	FS90030	NUT, MAIN PIVOT	79	FS90015	PIVOT WASHER, ST
37	FS80008	SCREW, M6 X 50 SHCS T30	80	FS80001	BEARING SS PIVOT
38	FS90025	PIVOT WASHER, MAIN	81	FS90008	LINK HALF, NDS
40	FS80004	SCREW, M6 X 14 FHCS T30 TORX	82	FS80010	O-RING 1.5 X 13
41	FS90026	FD MOUNT, CF SUSPENSION	83	FS90011	SHOCK PIVOT PIN, REAR
42	FS90024	PIVOT CAP, DS	84	FS80003	SCREW, TORX, M6 X 11
64	FS90028	CONE, DS, MAIN PIVOT	86	---	FOX FLOAT DPS EVOL 210 X 55
65	FS90029	CONE, NDS, MAIN PIVOT	89	---	SEAT COLLAR, 35.0
66	FS90012	SHOCK PIVOT PIN, FRONT	101	FS80012	O-RING 1.5 X 16

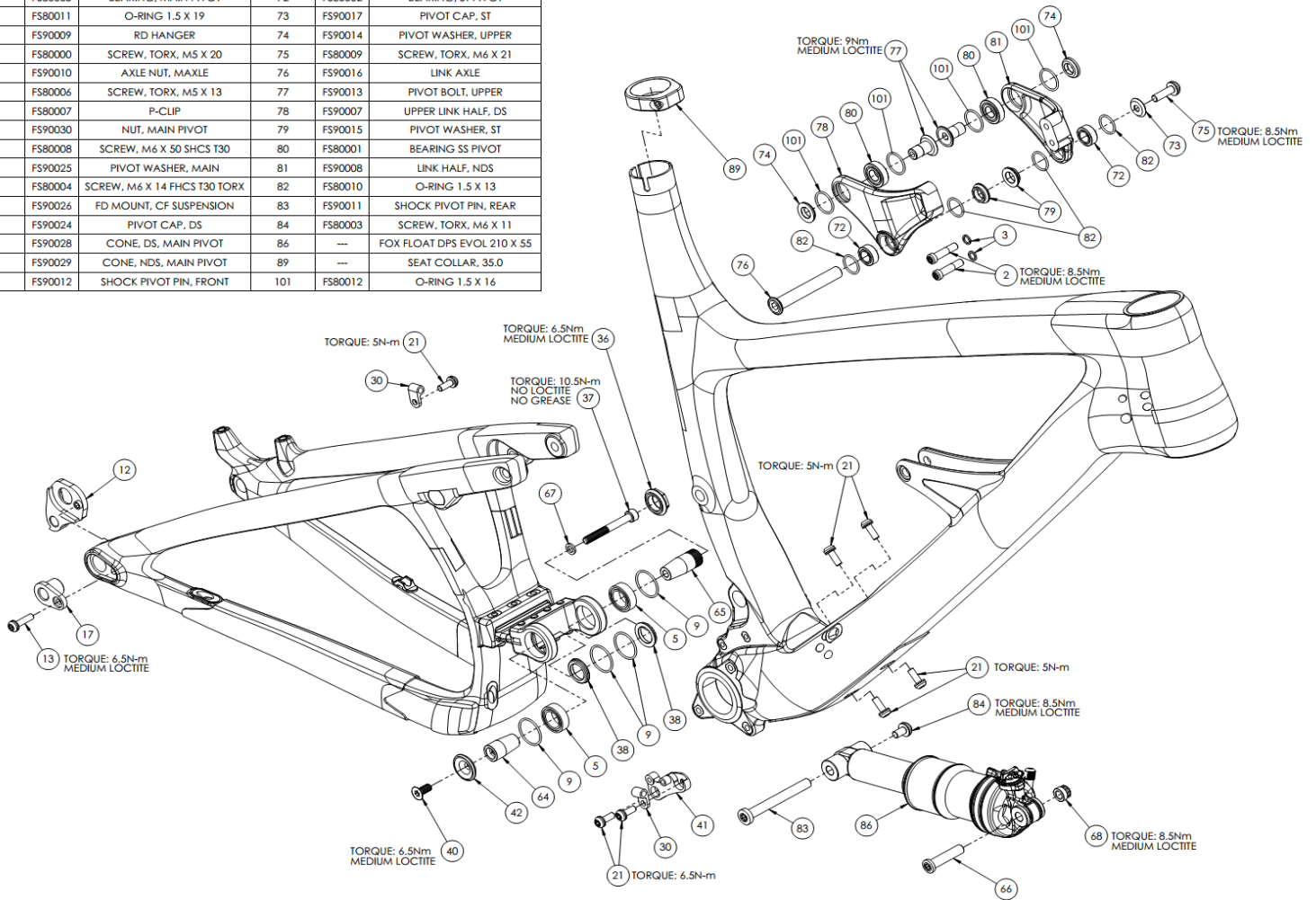

Now go shred!

# SPOT