

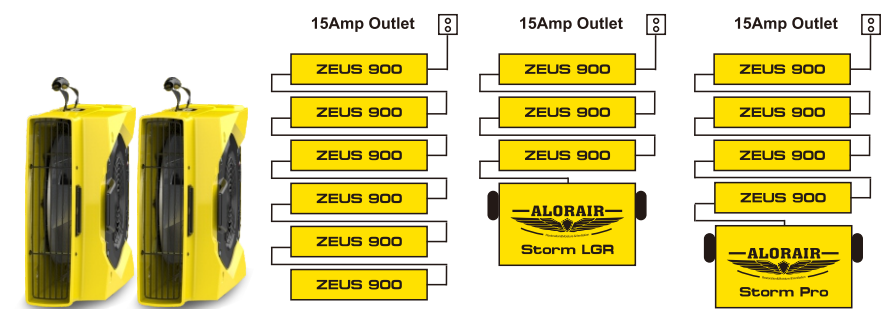

Control Panel

ALORAIR Radial Air Mover
With PATENT PENDING Technology
ZEUS 900
Easily to Carry!

Recommended Use Recommended use(s) of on-board duplex GFCI are shown.
Note: Standard 115VAC electrical outlets.
GFCI is not available for 220/240V



▼ Ducting Options and chain up to 6 fans



Half the height of standard carpet dryers ▶

► Operating Position



Applications	Zeus 900
Restoration Works	✓
Confined Aears	✓
Construction Sites	✓
Crawl Space&Basement	✓
Electric, Gas, Water Utilities	✓
Fire Departments	✓
Industrial Cleaning	✓
Manholes	✓

► Applications ◀

Drying and clear the air for workers or homeowners, especially with asthma or allergies. The kit features a HEPA media filter to minimize dust and particulates during restoration.

Compact size makes Zeus 900 the most compact and portable fan in its class. The rugged molded handle gives you the solid control during packing and unpacking lots of air movers. Its easy-winding cord wrap and multiple security options makes it safe and easy for transport. Zeus 900 is rock solid when stacked for transport as its mold features.

Zeus 900 is the most versatile air movement system available. With its patent pending, the Zeus 900 can deliver airflow of 950 CFM. The unit is stable in operation in all 5 drying positions with flexibility. Wherever adverse environmental pose a threat to health, safety and efficiency, Zeus 900 is the right solution for improving air quality.

Zeus 900 has the safest fan in its class as it has GFCI convenience receptacle which protects not only connected loads, but onboard components. GFCI is not available for 220/240V. This is unlike common fans on the market that require external GFCI protection.

Applications	Zeus 900
Municipalities	✓
Mines&Shafts	✓
Tunnels	✓
Tank Cleaning	✓
Telephone Crews	✓
Welding Booths	✓
Storage Areas	✓
Vaul Cleaning	✓



FIRE&FLOOD RESTORATION, CARPET DRYING, WAREHOUSES, WOOD FLOOR DRYING, CONCRETE DRYING, KITCHENS, FACTORIES



ALORAIR Radial Air Mover
With PATENT PENDING Technology
ZEUS 900



FASTEST / DRYING / EASILY TO CARRY

- Half The Size
- Ultra-Low Amps
- 5-position Versatility
- Ultra Secure Stacking



► PROVEN PERFORMANCE

The ZEUS 900 features focused airstream of 950 cfm and a lightweight stackable designed to fit in vehicle space, on-board duplex GFCI outlet, circuit breaker, and superior cord management.

The ZEUS 900, half the height of standard carpet dryers and draws just 1.8 amps! With the ZEUS 900's high velocity airflow, you can rapidly dry the largest area or tackle any problems with five versatile positions.

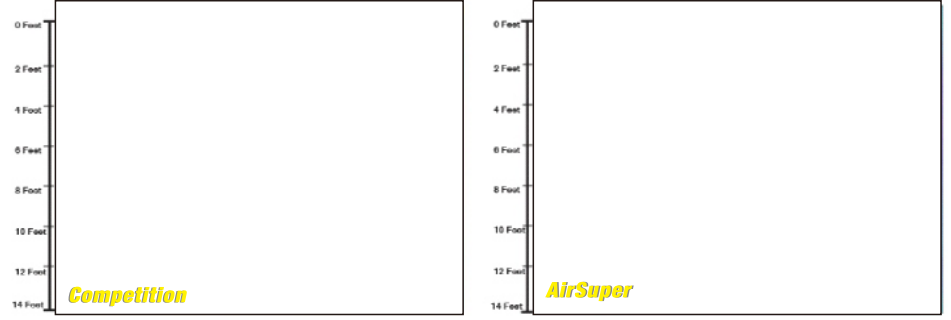

Features	ZEUS 900	Specifications	ZEUS 900
Less than 1.8 amps	✓	Fan	6 Blades
Duct at Outlet	✓	Control	On/Off Switch With Variable Speed
Power-on indicator light	✓	Voltage	115 VAC
Automatic hour meter displays site run time	✓	Current	1.8 Amps (High Speed)
Circuit breaker protects air mover and attached devices and prevents nuisance visits to the junction box	✓	Cord	20 ft Power Cord
GFCI promotes operator safety in wet applications	✓	Outlet	15A UL Rated GFCI Duplex Receptacle
20 ft AC cord with cord management	✓	Air flow	950 CFM, 1600 CMH
Units interlock for easy stacking in storage and handling	✓	Sound Pressure Level	<65 DBA
Daisy chain up to 6 fans on a single 15 Amp circuit	✓	Weight	24.2 lbs
Over 950 CFM	✓	Warranty	1 Year - 100% parts and labor (all components) 2 Year - 100% parts only (all components) 3 - 7 Year(s) - Materials and workmanship of the housing only.
Maintenance free Bearing Motor	✓	Dim(L*W*H)	21.6"×17"× 9"
Flex handle	✓	Static Pressure	1.7 in./H2O
5 drying positions to maximize flexibility	✓	Safety	ETL CE TUV SGS
LCD Display	✓	Loading quantity	20":378Sets/40":820Sets/40"HQ:924Sets

► Key Design Features ◀

- Half the height of standard carpet dryers and the draws just below 1.8 Amps
- Great chain up to 6 fans on a single 15 Amp circuit
- Greater air velocities than competitive products
- Maintenance free Bearing Motor, Low noise, quiet operation
- Onboard circuit breaker and branch protection GFCI
- Ultra secure stacking and cord wrap
- Lightweight and compact Linear Low Density Polyethylene (LLDP) housing is washable, chemical resistant and stacks for storage.

► Replacement Parts ◀

1. Breaker, CKT, 12A
2. Switch, On-Off-On
3. Outlet, GFCI, 15A
4. Grill Exhaust
5. Blade
6. Hour Meter
7. Rubber Fee
8. Impeller Assembly
9. Duct, Lay Flat, 14"×250'

AlorAir Solutions, Inc Add: 2048 East Francis st. Ontario, CA 91761 Tel: 1-888-990-7469 E-mail: sales@alorair.com