

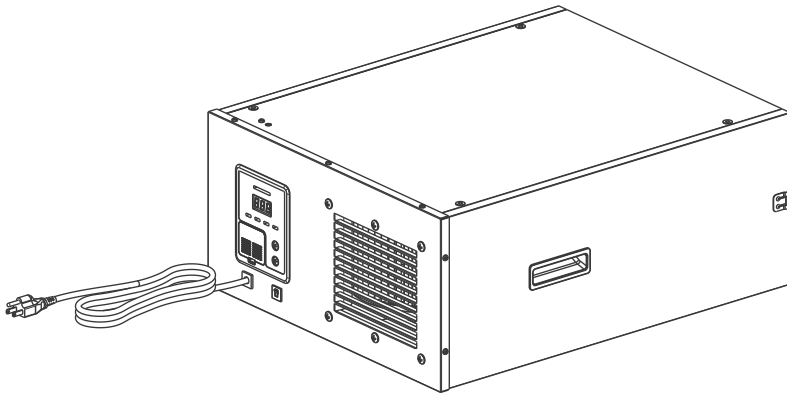

PuriCare1100/1100IG User Manual



PuriCare1100



PuriCare1100IG

READ AND SAVE THESE INSTRUCTIONS
Purisystems Solutions INC.

Add: 8605 SANTA MONICA BLVD#79525 WEST HOLLYWOOD, California,90069 USA

E-mail: sales@purisystems.com

WARNING!

Please note that the dust collector can only be used with Purisystems approved accessories. Using unauthorized accessories or making changes to the machine may invalidate your warranty. Please contact us for more details.

To Avoid Accidents:

- The power cord of the machine must be plugged into a grounded socket.
- The power supply of the machine must not be higher than the specified power supply.
- Do not use the machine after there is water inside the machine.
- The machine should not be installed outdoors or in places that may be eroded by Rain Water to avoid electricity leakage and fire.
- Do not run the machine without a filter installed.
- The machine has to be disconnected from power before it can operate internally.
- If hooks are installed on the ceiling, the load bearing capacity of the ceiling must be greater than 110 lbs.
- If the dust collector is to be installed on the ceiling, the distance between the bottom of the dust collector and the ground must be greater than 7 in.
- Installation requires two people.

INTRODUCTION

PuriCare1100/1100 IG is a kind of dust collector with small size and light weight. The machine is equipped with two filtering devices, which can reduce the weight on the premise of volume reduction, and effectively enhance the effect of air purification, which can deal with particles, dust, sawdust, pet sawdust and so on. Ingenious buckle structure is designed on both sides of the filter screen, which is very convenient for users to change the filter screen. And two kinds of simple fixed structures are designed on the top of the product, which improves the use of the product to the complex scene.

IDENTIFICATION

Congratulations on purchasing a Purisystems dust collector. In order to take advantage of the warranty plan, be sure to note the serial number and date of purchase.

Serial Number: _____

Date of Purchase: _____

HOW IT WORKS

1. Connect the dust collector to a standard 115V/60Hz outlet.
2. Refrain from moving the unit during operation.
3. Do not place a shield within the 600mm around the air inlet and outlet of the product.
4. This product can only filter dust particles above 1um.

SPECIFICATION

PuriCare1100		PuriCare1100IG	
Power	110-120,60Hz, 1.8A	Power	110-120,60Hz, 1.8A
Control mode	Manual / remote control	Control mode	Manual / remote control
Wind speed	LO/MID/HI Low/Middle/High	Wind speed	LO/MID/HI Low/Middle/High
Timing	1H、 2H、 3H 4H、 5H、 6H	Timing	1H、 2H、 3H 4H、 5H、 6H
Noise	(HI) ≤66dB	Noise	(HI) ≤66dB
Net weight	33 lbs	Net weight	33 lbs
Size	24.6 x 20.1 x 10.6 in 33 lbs	Size	24.6 x 20.1 x 10.6 in 33 lbs
Ion Fuction	No	Ion Fuction	Yes

KEY FEATURES

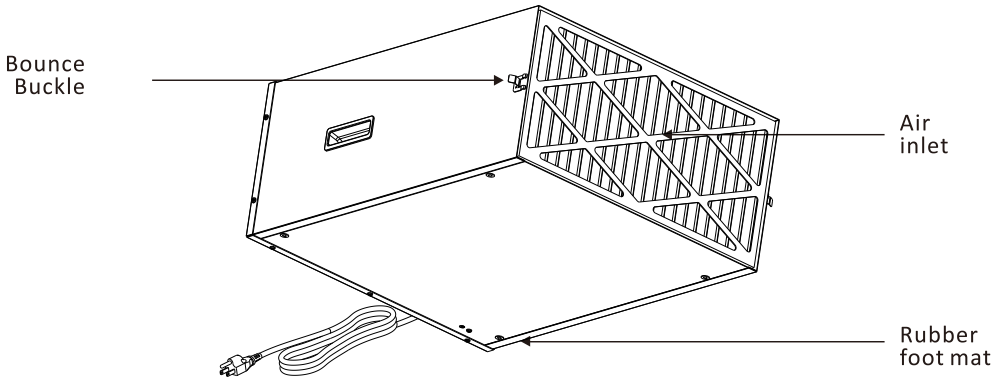
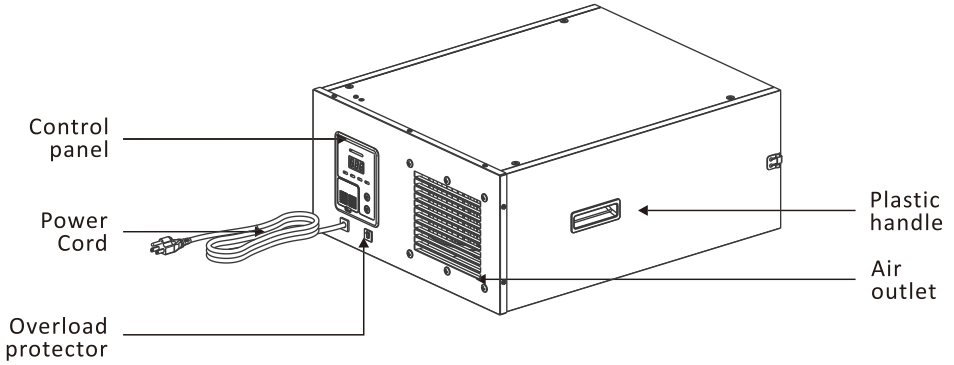

INSTRUCTIONS

CONTROL PANEL

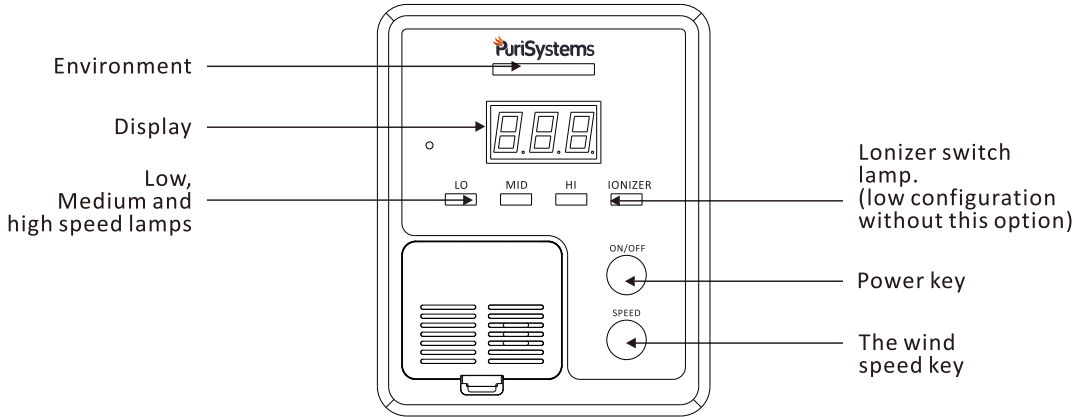

REMOTE CONTROL

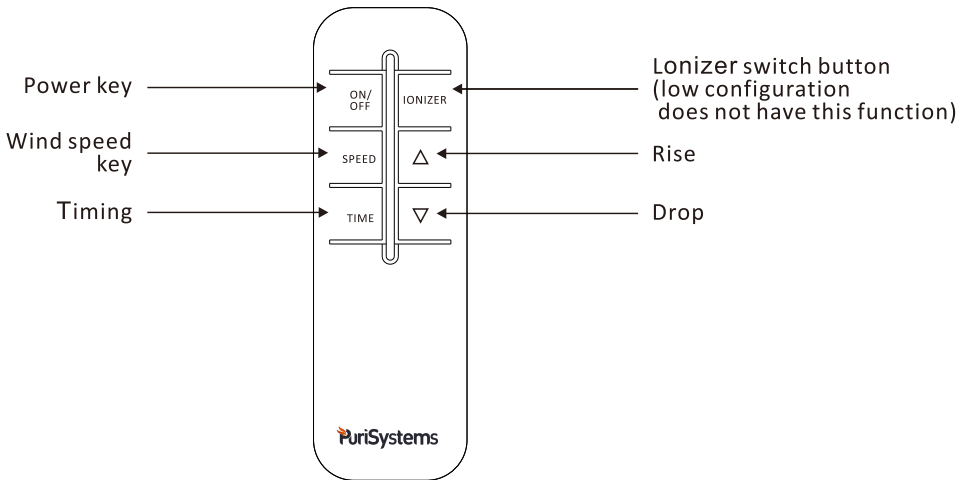

1. Power key:

Turn on and off air filtration equipment

Click the control panel "ON/OFF" /remote control"ON/OFF".The machine will make a "drip" sound, the environment prompt light will be on, and the display screen will display the PM number of the environment.

2. Wind speed key:

Control the wind speed of Low, Middle and High. Each time it is operated, the light of the control panel will switch to one of the wind speed gears, and the light represents the wind speed of the current gear.

3. Timing:

Control the working hours of the machine:

Operate the remote control "TIME" button. The display screen will display a timing number. , Operate the "TIME" button once, and display the content once (0H, 1H, 2H, 3H, 4H, 5H, 6H). 0H stands for indefinite time, (1H, 2H, 3H, 4H, 5H, 6H) the number,is the running time of the machine, and H represents the hour. After setting the working hours, the display content automatically switches to the environment PM to detect the content value, which means that the command takes effect and starts the countdown work.

4. Ionizer switch button:

Description: this button is only used on the remote control, which is a general accessory. The low-end version does not have this feature, so you need to pay attention to the version model when you buy it.

Operate the "IONIZER" button of the remote control. the ionizer switch light on the control panel is on,the ion function starts, and operate again, the ionizer switch light is off and the ion is off.

5. Rise Drop:

Description: this button function is only used on the remote control. Operate the up arrow and down arrow of the remote control.Set the desired PM number.The setting number can be switched within CO- 80 0, and the display number rises or decreases by 50 peroperation. The minimum CO number is set to represent the continuous operation of the machine and is not affected by thePM sensor. When the PM number in the display screen is higher than the set number, the machine is running.

Environmental warning lamp			
Color	Green	Yellow	Red
Environment	Excellent	Good	Bad
Note: please pay attention to the air quality of the room when it is shown in red.			

HOW TO INSTALL DUST COLLECTOR

Installation mode 1

1. Fix the hook as shown in the picture to 4 holes at the top of the machine with M4 nut. M4 nut needs to be tightened to prevent the hook from rotating and falling off.
2. Fasten the horn hook to the ceiling.
3. One person picked up the dust collector and the other connected the other end of the chain to the machine hook.
4. Due to the impact of the machine itself and the environment, there will be installation imbalance, the number of sections of the chain hook can be used to adjust the machine balance.

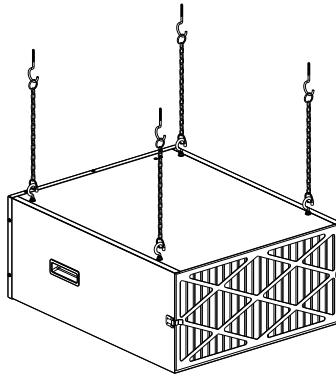

Installation mode 2

1. Remove the four M4 screws from the top of the machine, install the pendant as shown in the picture, and fix the M4 screws just now.
2. One man picked up the dust collector and the other screwed the machine to the wall.

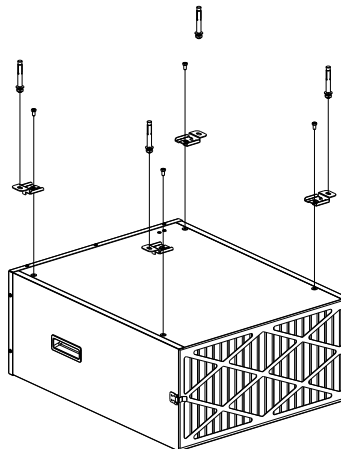

HOW TO REPLACE THE FILTER

- (1) Turn off the machine before replacement.
- (2) The buckles on both sides of the filter are broken to both sides.
- (3) Remove the filter.
- (4) Install a new filter.
- (5) Pay attention to the sequence of filters.

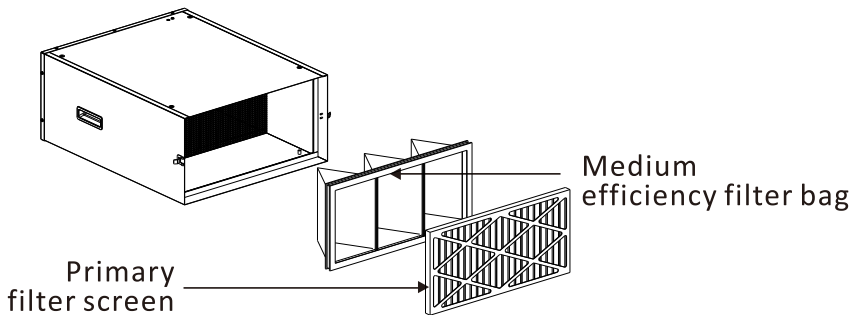
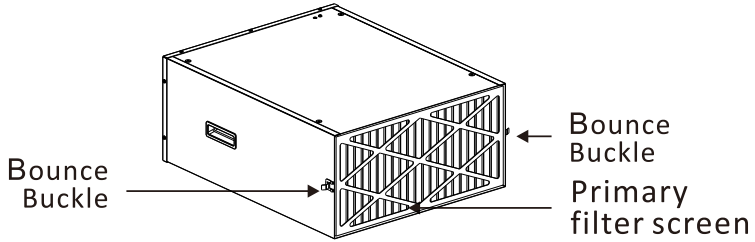

MAINTENANCE AND CLEANING

Under poor air quality, there will be a lot of dust in front of the control panel, which needs to be cleaned up.

1. Disconnect the power supply before cleaning.
2. Open the cover next to the button on the machine control panel.
3. Use a brush to dust the lid. Then put the lid on and plug it in.

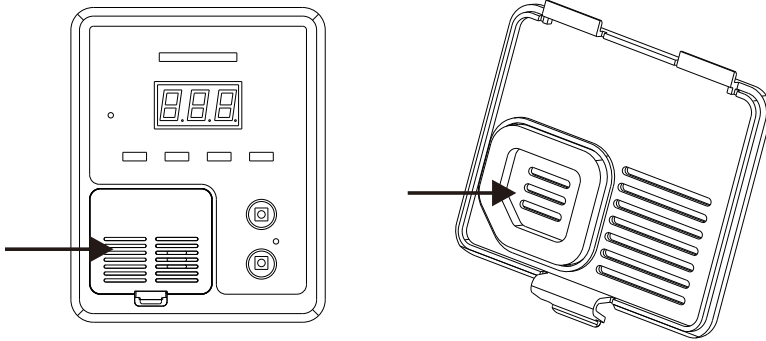

INSPECTION AND TROUBLESHOOTING

1. The display shows three "000", the motor stops working, and the PM2.5 concentration indicator shows red, indicating a problem with the PM sensor. It needs to be maintained and cleaned up.
2. If the machine is short-circuited and there is a power outage at home, the overload protector will cut off the circuit to protect the machine.

POWER-OFF PROTECTION TREATMENT

1. Unplug the machine.
2. Press the overload protector button back to its original position by hand.
3. Plug in the power supply and start up.

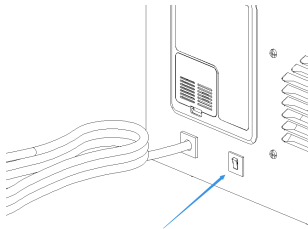

LIMITED WARRANTY

The limited warranty is applicable to the original purchaser only, since the date of purchase. It should subject to the terms and conditions listed in this limited warranty file.

WARRANTY PERIOD

Warranty becomes effective since the date of original purchase and will last for one (2) years.

- Who's covered?

This limited warranty is only effective for the original purchaser. It is NOT transferable.

- Who's Not covered?

1. Damage caused by the owner when attempting to fix or alter the product by himself or herself.
2. Damage caused by misuse, abuse, neglect, alterations or unauthorized repair.
3. Natural depreciation.

- How to request warranty services?

To obtain the benefit of this warranty, please leave your message online (www.purisystems.com), or send an email to sales@purisystems.com. Our customer service will address your issue within 24hs.

Purisystems Warranty Steps:

1. Once goods are received, customers must log in www.purisystems.com to fill out the warranty registration form and submit to purisystems company. We will receive your purchasing and installation information and save it. If no warranty registration is sent to us, warranty period will begin the day the shipment left the warehouse. Please be sure to record serial # and date of installation. You will need this information to receive the RA number.
2. If warranty service is necessary, customers must contact purisystems Tech Support by sales@purisystems.com or local technical service phone to receive a Return Authorization (RA number). Once an RA has been issued, customers should bring the unit to a certified repair center. purisystems will arrange the shipping to bring the unit back to the purisystems warehouse (at the expense of the customers) if customers are not available.
3. After the unit has been received by purisystems (whether at a repair center or the warehouse), purisystems will have an initial inspection. If it is determined to be an invalid warranty claim (see exclusions below), customers have to pay for all associated repair costs and shipping costs for units repair.
4. Customers can pick up the unit after repair at their own expense for shipping. Units will have a rigorous testing before sending it back to customers.
5. If the unit can no longer be fixed, and it is in the warranty period and determined to be a valid claim, we will ship the customer a new unit within the same year warranty from the date of replacement.
6. After parts are repaired or replaced by purisystems, the original warranty period continues to apply until it meets its deadline. No extensions to the original warranty period.

Warranty Exclusions:

DAMAGE DUE TO THE FOLLOWING IS NOT covered under warranty

1. Acts of Nature- including but not limited to:

Flooding

Fire

Water damage

Hurricane/storm damage

2. IMPROPER USAGE- Including but not limited to:

Misuse, abuse, or tampering whether intentional or accidental

Improper installation or design

Improper voltage

Lack of normal care

Failure to follow instructions

3. Corrosion

4. Freezing

5. Any additional costs due to changes in laws or building codes

6. Freight charges

7. Any costs due to lost profit or delay

8. Damage to property

9. Cause beyond control

10. Consumable parts, including but not limited to:

Filters

Batteries

Power cords

Valves

Switches

Rubber parts

11. Direct, indirect, collateral or inconsequential damages of any kind

THE WARRANTIES AND LIABILITIES SET FORTH ARE IN LIEU OF ALL OTHER WARRANTIES EXPRESSED OR IMPLIED, IN LAW OR IN FACT, INCLUDING IMPLIED WARRANTIES OF MERCHANTABILITY AND FITNESS FOR A PARTICULAR PURPOSE.

Purisystems total liability, regardless of nature of claim shall not exceed original purchase price of the product. If a product or component is replaced while under warranty, the applicable warranty period shall not be extended beyond the original warranty time period.

The foregoing shall constitute the total liability of seller in the case of defective performance of all or any of the equipment or services provided to Buyer. Buyer agrees to accept and hereby accepts the foregoing as the sole and exclusive remedy for any breach or alleged breach of warranty by Seller.

Any dishonesty or fraud in connection with Purisystems warranty thoroughly voids all warranty policies. Purisystems expressly reserves the right to pursue legal action in the event of dishonesty, fraud, or attempted fraud.

Wiring Diagram

