

# PRODUCT CATALOG

*The Leader in  
Fueling Systems Since 1967*

**WORK FASTER, CLEANER, SAFER**

**Wiggins**  
Systems



# Refueling Nozzles

## ZZ9A1



- Industry-standard diesel refueling nozzle
- 150 gpm (570 lpm) maximum flow rate
- Automatic shutoff; works with pressurizing and non-pressurizing systems
- 1.5" NPT female inlet thread
- Durable, dependable Elast-O-Dog latching
- Field-replaceable components

<b>Min. Flow Rate</b>	25 gpm (95 lpm)
<b>Max. Flow Rate</b>	150 gpm (570 lpm)
<b>Operating Pressure</b>	75 psig (520 kPa)
<b>Weight</b>	5.64 lbs (2.56 kg)

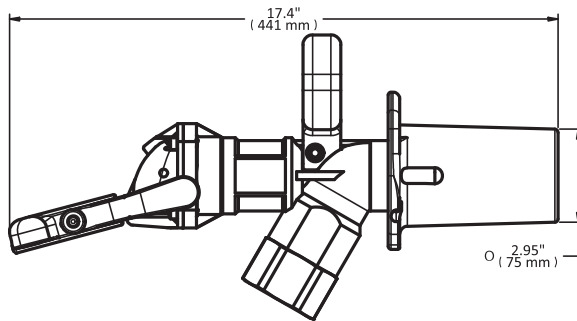

## ZZ9A2



- High-flow rate diesel refueling nozzle
- 211 gpm (800 lpm) maximum flow rate
- Automatic shutoff; works with pressurizing and non-pressurizing systems
- 2" NPT female inlet thread
- Durable, dependable Elast-O-Dog latching
- Field-replaceable components

<b>Min. Flow Rate</b>	25 gpm (95 lpm)
<b>Max. Flow Rate</b>	211 gpm (800 lpm)
<b>Operating Pressure</b>	75 psig (520 kPa)
<b>Weight</b>	6.10 lbs (2.77 kg)

