

PRODUCT CATALOG

*The Leader in
Fueling Systems Since 1967*

WORK FASTER, CLEANER, SAFER

Wiggins
Systems



Integrated Jet Level/Sensor/Vent

JVX



- Vent assembly with integrated jet level sensor,
- 3 psig relief valve, and spill protection
- Jet level sensor does not have moving parts: it is extremely reliable
- 2" NPT male thread for mounting to tank
- Short sensor length

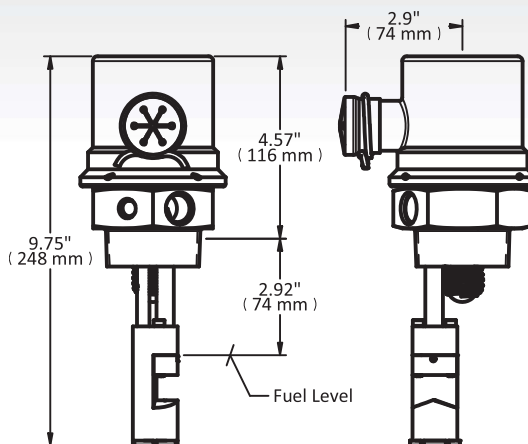

Operating Pressure 75 psig (520 kPa)

Weight 1.72 lbs (0.78 kg)

JVXL



- Vent assembly with integrated jet level sensor,
- 3 psig relief valve, and spill protection
- Jet level sensor does not have moving parts: it is extremely reliable
- 2" NPT male thread for mounting to tank
- Long sensor length

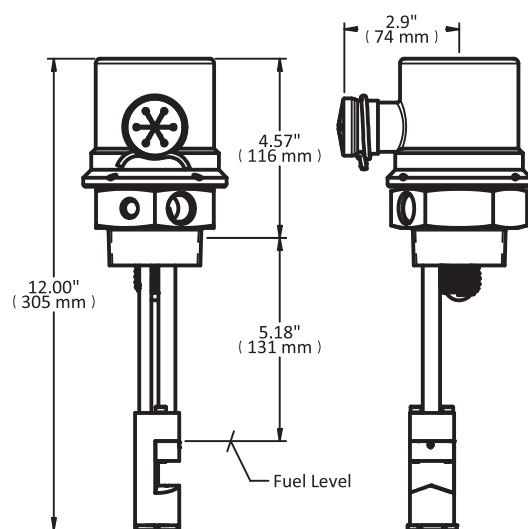

Operating Pressure 75 psig (520 kPa)

Weight 1.74 lbs (0.79 kg)