



MODELS 82791, 82792, 82793, 82841, 82883, 83271, 83398, 83665, 84663
POWER-MASTER DRUM PUMPS
(SHOVEL TYPE FOOT VALVE)

! WARNING
DO NOT OPERATE WITH COMBUSTIBLE GAS.

ATTACHING AIRMOTOR TO PUMPTUBE

1. Tightly connect airmotor coupling nut to pump plunger.
2. Attach airmotor to the pump outlet body flange with the four bolts and nuts (hand tight) supplied with airmotor.
3. Slowly cycle the pump several times, using just enough air pressure to operate the pump without stalling.
4. Stop the pump on an "up" stroke and tighten the four bolts & nuts to securely fasten the airmotor to the pumptube.

MODEL CHART

(*Size of airmotor used with pumptube determines pump ratio.)

PUMPTUBE	PUMP MODEL	*RATIO	MAXIMUM AIR PRESSURE	AIRMOTOR	AIRMOTOR SERVICE PAGE
82791	1902	24:1	200 psi	82730	A-50 Pg. 3 Series
	1922	48:1	100 psi	82736	A-50 Pg. 3 Series
	1932	8:1	200 psi	82737	A-50 Pg. 1 Series
	1962	84:1	100 psi	83435	A-50 Pg. 6 Series
82792	1903	40:1	200 psi	82730	A-50 Pg. 3 Series
	1923	80:1	100 psi	82736	A-50 Pg. 3 Series
	1933	13:1	200 psi	82737	A-50 Pg. 1 Series
82793	1904	75:1	110 psi	82730	A-50 Pg. 3 Series
	1934	25:1	200 psi	82737	A-50 Pg. 1 Series
82841	1907	40:1	200 psi	82730	A-50 Pg. 3 Series
	1938	13:1	200 psi	82737	A-50 Pg. 1 Series
82883	1908	75:1	110 psi	82730	A-50 Pg. 3 Series
	1939	25:1	200 psi	82737	A-50 Pg. 1 Series
83271	1910	50:1	150 psi	82730	A-50 Pg. 3 Series
83398	1911	50:1	150 psi	82730	A-50 Pg. 3 Series
83665	1935	50:1	150 psi	82737	A-50 Pg. 1 Series
84663	1941	50:1	150 psi	82737	A-50 Pg. 1 Series

MODELS 82791, 82792, 82793, 82841, 82883, 83271, 83398, 83665, 84663
POWER-MASTER DRUM PUMPS
 (SHOVEL TYPE FOOT VALVE)

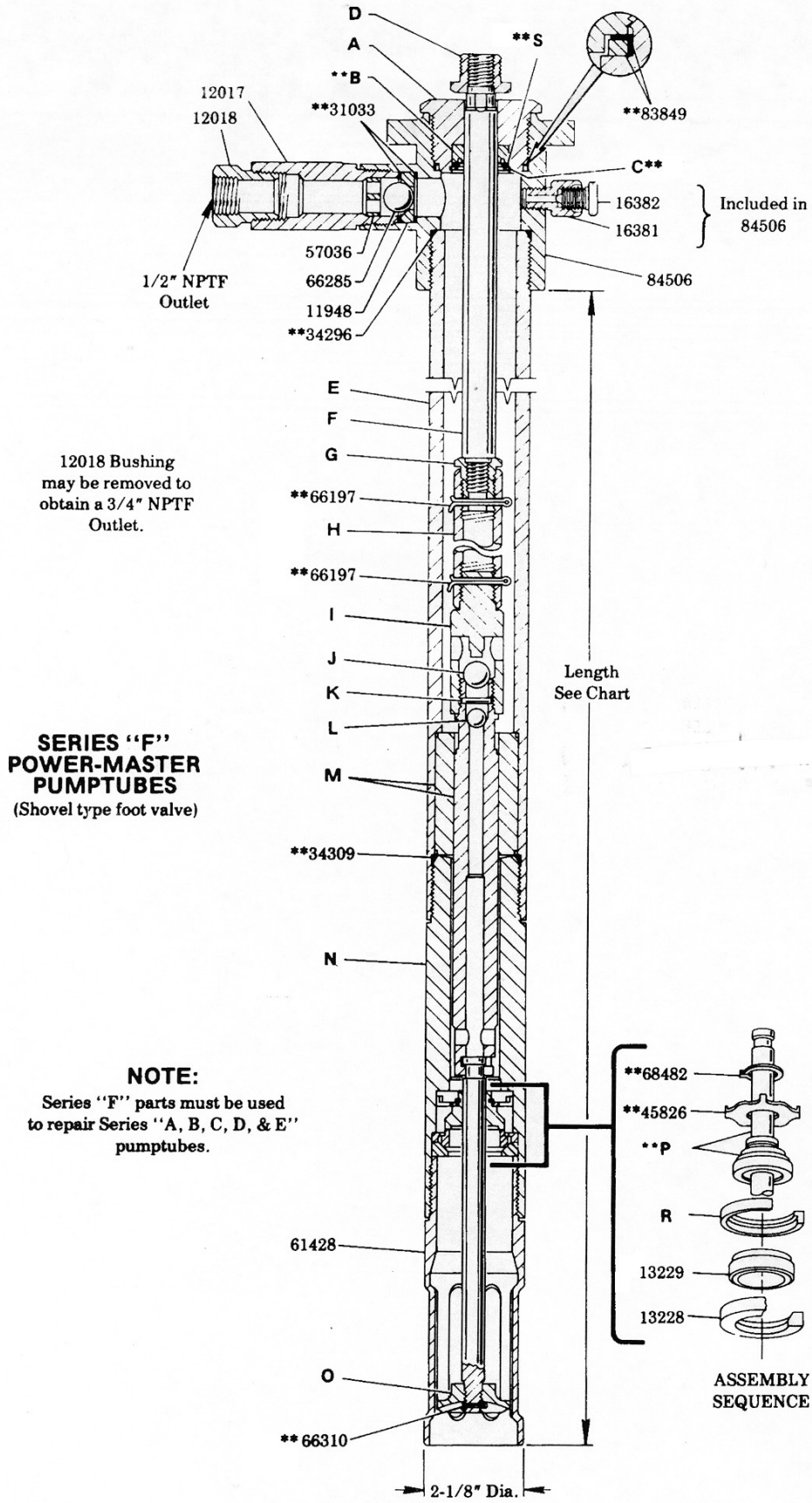



MODELS 82791, 82792, 82793, 82841, 82883, 83271, 83398, 83665, 84663
POWER-MASTER DRUM PUMPS
(SHOVEL TYPE FOOT VALVE)

		MODEL								
CODE	DESCRIPTION	82791	82792	82793	82841	82883	83271	83398	83665	84663
A	Gland nut	93294	93291	93288	93291	93288	93293	93293	93290	93290
B	U-cup packing	34406	34402	34403	34402	34403	34407	34407	34450	34450
C	Retaining ring	68908	69282	69281	69282	69281	69282	69282	69281	69281
D	Coupling adapter	15014	15014	15014	15014	15014	15014	15014	15016	15016
E	Extension tube	61493	61493	61493	61494	61494	61493	61494	61493	61494
F	Plunger (Plunger diameter)	13374 (.966")	13375 (.808")	13376 (.686")	13375 (.808")	13376 (.686")	13996 (.761")	13996 (.761")	14306 (.582")	14306 (.582")
G	Plunger adapter			13242		13242			13242	13242
H	Extension rod	62932	62932	62932	62935	62935	62932	62935	62932	62935
I	Adapter	13230	91917	91916	91917	91916	91917	91917	92181	92181
J	Upper check ball	66728	66071	66285	66071	66285	66071	66071	66030	66030
K	Pin	13231	13237	13240	13237	13240	13237	13237	14308	14308
L	Lower check ball	66285	66030	66007	66030	66007	66030	66030	66957	66957
M	Bushing & plunger	91513	91516	91517	91516	91517	91923	91923	92253	92253
N	Adapter tube	61430	61621	61619	61621	61619	61619	61619	61520	61520
O	Priming nut	13235	13235	13235	13235	13235	13235	13235	14541	14641
P	Priming bushing & plunger	91514	91514	91514	91514	91514	91514	91514	92254	92254
R	Retainer	13227	13227	13227	13227	13227	13227	13227	14811	14811
S	Washer	48614	48621	48620	48621	48620	48621	48621	48620	48620
	Bung bushing (accessory)	83132	83132	83132	83132	83132	83132	83132	83132	83132
	Follower plate (accessory)	83369	83369	83369	84780	84780	83369	84780	84780	84780
	Drum cover (accessory)	81412	81412	81412	81538	81538	81412	81538	81412	81538
	Output per cycle (cubic inches)	5	2.8	1.6	2.8	1.6	2.3	2.3	0.6	0.6
	Pumptube length (inches)	34	34	34	27-3/8	27-3/8	34	27-3/8	34	27-3/8
	Drum size (pounds-gallons)	400-55	400-55	400-55	120-16	120-16	400-55	120-16	400-55	120-16
	©Repair Kit (Parts Indicated **)	86231	86232	86234	86232	86234	86233	86233	83047	83047
	©Check	13229	13229	13229	13229	13229	13229	13229		

SERVICE PARTS

(Common to all models)

PART	QUAN.	DESCRIPTION
11948	1	Outlet check seat
12017	1	Outlet primer body
12018	1	Reducer
13228	1	Check seat
13229	1	Check
16381	1	Adapter
16382	1	Priming plug
31033	2	Gasket
34296	1	O-ring
34309	1	O-ring
45826	1	Guide
57036	1	Ball stop
61428	1	Priming tube
66197	2	Cotter pin
66285	1	Steel ball
66310	1	Cotter pin
68482	1	Spring washer
83849	1	Packing retainer assembly
84506	1	Outlet body

POWERMASTER PUMPS

(PLUNGER SIZES OF THE BUSHING & PLUNGER - SEE ITEM 'M')

PART	SIZE
82791	1.269
82792	1.029
82793	0.836
82840	1.289
82841	1.029
82883	0.836
83271	0.953
83398	0.953
83665	0.662
84663	0.662

See pump accessories on back page.

© Indicates change



ACCESSORIES

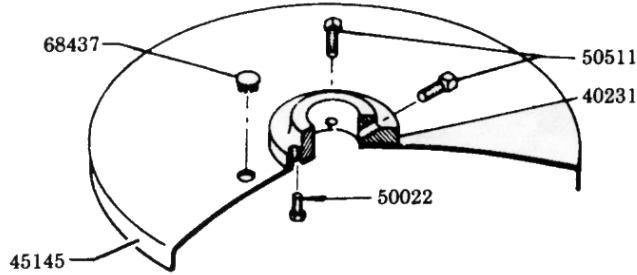

81412
DRUM COVER ASSEMBLY
 (400 LB. DRUM)

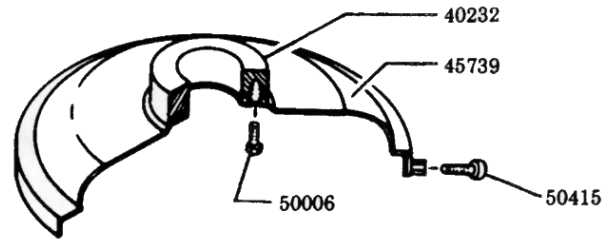

81538
DRUM COVER ASSEMBLY
 (120 LB. DRUM)



83132
BUNG BUSHING

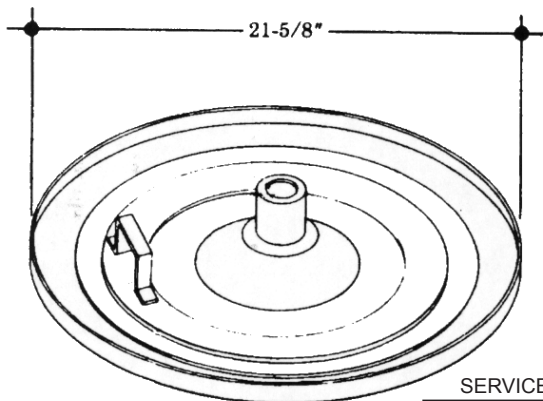

83369
FOLLOWER
 (400 LB. DRUM)

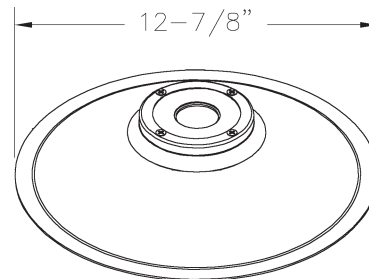

84780
FOLLOWER
 (120 LB. DRUM)

SERVICE PARTS FOR ACCESSORIES

PART	QUAN.	DESCRIPTION
40231	1	Flange
40232	1	Flange
45145	1	Drum cover
45739	1	Drum cover
50006	4	Screw
50022	4	Screw
50415	3	Screw
50511	2	Screw
68437	1	Snap button

Americas:
 One Lincoln Way
 St. Louis, MO 63120-1578
 USA
 Phone +1.314.679.4200
 Fax +1.800.424.5359

Europe /Africa/Middle East
 Lincoln GmbH
 Heinrich-Hertz-Str. 2-8
 69190 Walldorf - Germany
 Phone/Fax +49.6227.33-0/-259
 www.lincolnindustrial.de

Asia/Pacific:
 No. 3 Tampines Central 1
 #04-05, Abacus Plaza.
 Singapore 529540
 Tel +65.6588.0188
 Fax +65.6588.3438

© Copyright Lincoln Industrial
 Corporation 2010
 Printed in USA

Web site:
 www.lincolnindustrial.com