

OWNER/OPERATOR MANUAL

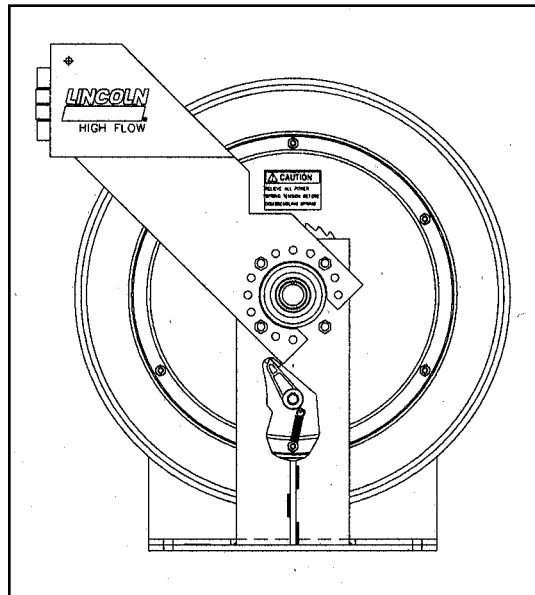

SPECIFICATIONS

Maximum working pressure	2000 p.s.i.
Material Inlet	3/4" NPT (Female)
Material outlet	3/4" NPT (Female)
Sheave width	10"
Sheave diameter	19-1/4"
Drum diameter	12-3/4"
Overall width	15-1/2"
Overall height	22-1/2"
Overall depth	21"

Maximum hose capacities (Including hang down):
5/8" or 3/4" I.D. Hose 75 Ft.

NOTE: Maximum hose capacities are based on SAE specified hoses. Exceeding these capacities voids warranty. Refer to DELIVERY HOSE INSTALLATION for proper hose to reel assembly.

DESCRIPTION

Model 84673 unit is a heavy duty lubreel designed for bus and truck lubrication or wherever extra heavy duty construction and longer length delivery hose is required. The reel can be installed as a single unit or in multiple configurations.

Reel features include a reel latch that automatically locks at desired positions as the hose is extended and releases with a short pull on the hose.

OWNER/OPERATOR RESPONSIBILITY

It is the owner/operator responsibility to properly use and maintain this equipment.

The instructions and warnings contained in this manual

shall be read and understood by the owner/operator prior to operating this equipment.

If an owner/operator does not understand English, the contents of this manual shall be explained in the owner/operator native language to assure the owner/operator comprehends.

It is the owner/operator responsibility to maintain the legibility of all warning and instruction labels.

The owner/operator shall retain this manual for future reference to important warnings, operating and maintenance instructions.

© Indicates change

WARNING

Systems which will be dispensing fluids under pressure may need to be protected by using a thermal relief kit, which will safely limit the pressures caused by thermal expansion. Please contact your local Lincoln distributor and refer to Service Page Section K5, Page 31 for more details. Failure to include thermal relief protection may cause damage not covered under Lincoln's warranty policy.

WARNING

FAILURE TO HEED THE FOLLOWING WARNINGS INCLUDING MISUSE, OVER PRESSURIZING, MODIFYING PARTS, USING INCOMPATIBLE CHEMICALS AND FLUIDS, OR USING WORN OR DAMAGED PARTS, MAY RESULT IN EQUIPMENT DAMAGE AND/OR SERIOUS PERSONAL INJURY, FIRE, EXPLOSION, OR PROPERTY DAMAGE.

- Do not exceed the stated maximum working pressure of the reel or of the lowest rated component in your system.
- Do not alter or modify any part of this equipment.
- Do not operate this equipment with combustible gas.
- Do not attempt to repair or disassemble the equipment while the system is pressurized.
- Make sure all fluid connections are securely tightened before using this equipment.
- Always read and follow the fluid manufacturers recommendations regarding fluid compatibility, and the use of protective clothing and equipment.
- Check all equipment regularly and repair or replace worn or damaged parts immediately.
- Never point the dispensing valve at any part of the body or at another person.
- Never try to stop or deflect material from dispensing valve or leading connection or component with your hand or body.
- Always check equipment for proper operation before each use, making sure safety devices are in place and operating properly.
- Always follow the pressure relief procedure after shutting off the pump, when chocking or servicing any part of the system, and when installing, cleaning or changing any part of the system.

ASSEMBLY

Assemble reel as follows. Refer to SERVICE PARTS for part numbers and location.

- A. Assemble arbor and ratchet casting (237769) to support assembly (237656) with hex head screws (50014) and secure with hex nuts (51022).
- B. Lubricate V-ring seal (237671) and assemble onto arbor and ratchet casting (237769) with lip facing away from arbor ratchet.
- C. Assemble power spring assembly (248494) onto arbor and ratchet casting (248494) until spring canister bottoms on arbors shoulder.
- D. Lubricate V-ring seal (237673) and assemble onto arbor and ratchet casting (237769) with lip facing toward spring canister.
- E. Assemble axle assembly (242000) to sheave assembly (237771) and secure with standoffs (237780).
- F. Assemble axle and sheave assembly to reel by sliding the axle assembly (242000) through the bearings in the arbor and ratchet casting (237769) and securing with washer (48217) and Tru-arc (68424).

Note: Shim as required using shims (48385) between washer (48217) and arbor and ratchet casting (237769) to eliminate axle end play.
- G. Assemble outboard axle assembly (237781) to standoffs (237780) and secure with nuts (51412).
- H. Rotate sheave assembly (237771) and align mounting holes with mating holes in power spring canister (248494) and secure using carriage bolts (237738), carriage bolt (237739) and nuts (51412). Note: The carriage bolt (237739) (.875 long) must be assembled in hole adjacent to pawl pin on power spring assembly.
- I. Assemble rollers onto 5/16" diameter pins in the order illustrated on page (6). Hold in place while inserting the four 5/16" washer head bolts through the assembly and secure with four 5/16" washer head nuts. Assemble roller outlet arm assembly onto three of the bolts (50014) and secure using three nuts (51022).
- J. Assemble swivel assembly(84679) in axle assembly (242000) and tighten.
- K. Assemble swivel outlet adapter (242015) into the axle assembly (242000) and secure.
- L. Assemble hose clamp (272382) to sheave assembly (237771) with carriage bolt (237738) and secure with nut (51010).
- M. Assemble pawl (237683) to pawl pin on spring canister (248494) and secure with washer (48327) and Tru-arc (66316).

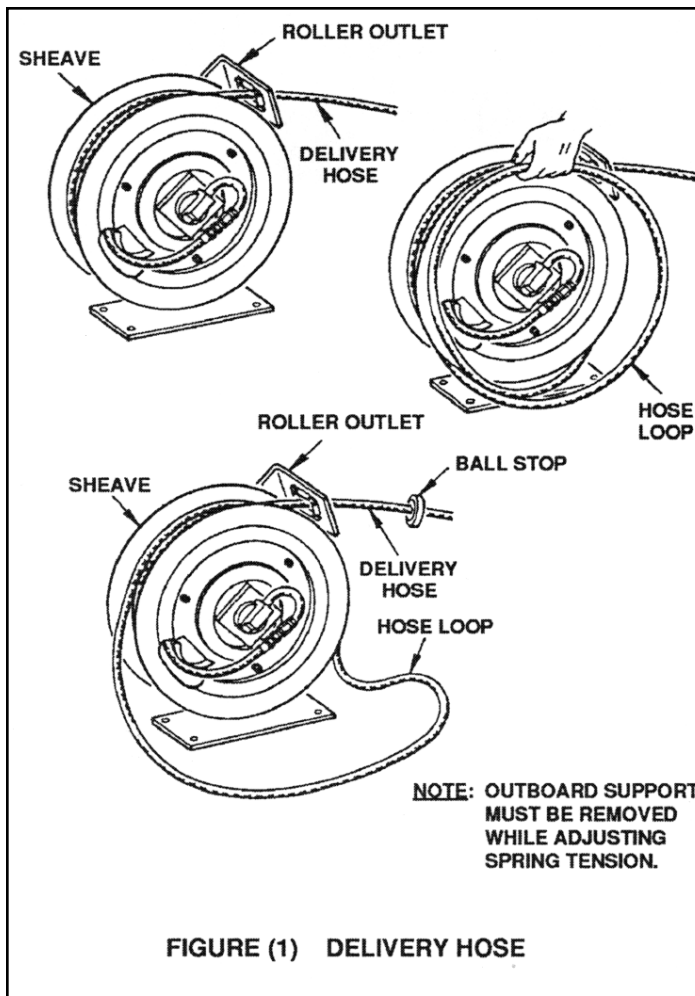

FIGURE (1) DELIVERY HOSE

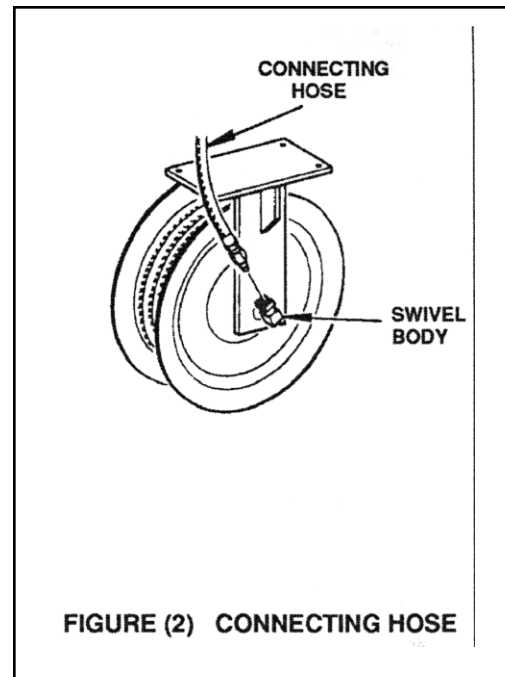

FIGURE (2) CONNECTING HOSE

See Figure (1). Insert hose end with outlet adapter through roller outlet and secure to axle head with U-keeper. Make sure seal is installed correctly in axle before assembling.

- N. Assemble pawl spring (237695) to pawl (237683) and carriage bolt (237739) and secure with locknut (51304).
- O. Install Bearing (242725) into Outboard Bearing Assembly (237784) and secure with Bearing Retainer (69281). Attach completed Assembly to the Outboard Support (237787) using screws (50016). **HAND TIGHTEN ONLY AT THIS POINT.**
- P. Assemble outside bearing assembly and support to reel assembly by sliding outboard axle through bearing. Align two .406 mounting holes in both base and support and insert one roll pin in each hole.
- Q. Adjust/align outside bearing assembly for free drum.

**INSTALLATION
DELIVERY HOSE
DELIVERY HOSE INSTALLATION (MAXIMUM
SPRING TENSION)**

For smoother operation during retraction and to increase hose life, "detaic" hose by wiping entire hose length with a light lubricating oil before installing on reel.

Assemble outlet adapter to hose and tighten securely. Use teflon tape on threads to prevent leaks.

! CAUTION

To prevent damaging hose connections and/or components when pulling hose from reel, pull on the hose itself and not on the control valve or swivel. Do not pull or jerk on the hose when fully withdrawn from the reel.

From open side of reel (with outside support removed), loop entire length of hose onto reel in a clockwise direction. Pull hose out through roller outlet to wind power spring. When hose is completely extended, latch reel to prevent it from unwinding.

Continue to add loops of hose and pull out hose until power spring winds tight.

**IMPORTANT
INSTRUCTIONS**

Perform the following instructions as stated to correctly set the power spring for maximum tension.

Allow reel to retract two full revolutions and latch reel. Carefully unloop remaining hose from reel.

CAUTION

To avoid damaging reel components, always make sure hose clamp is properly installed.

Position hose clamp so that approximately 1/2 loop of hose remains on reel and latching does not occur when hose is fully extended.

Slide ball stop over free end of hose and position slightly below roller outlet. Tighten screws to secure ball stop to hose.

Power spring is now set to maximum tension.

ADJUSTING SPRING TENSION

CAUTION

To prevent premature power spring failure, spring tension should be adjusted so that it requires at least two full turns of the reel sheave before the spring is wound tight.

Should less spring tension be desired, pull hose out from roller outlet to provide slack and latch reel.

Unwind one loop of hose from reel. Pull excess hose out through roller outlet and unlatch reel to retract hose.

Check tension and repeat above procedure until desired tension is obtained.

Reattach/assemble outboard support to reel. (See Page 3, Steps 0 thru 0).

ATTACHING CONNECTING HOSES

CAUTION

To prevent damage to connecting hose when installing hose to reel, sufficient clearance must be provided from outside edge of sheave.

See Figure (2). Reconnect inlet adapter to swivel body and replace U-keeper.

Connect other end of connecting hose to material supply line source or connection.

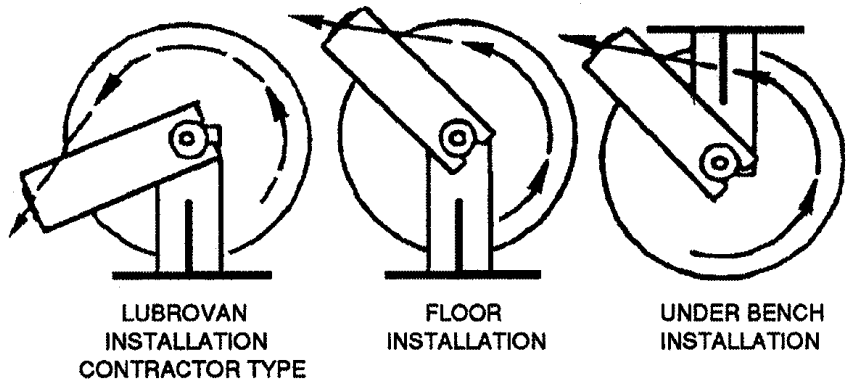
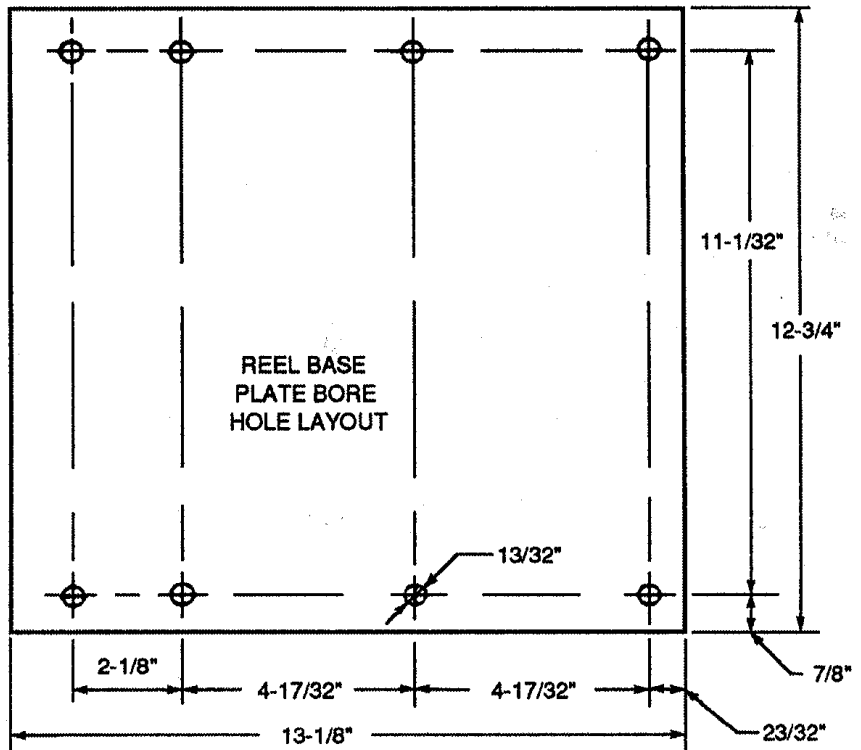
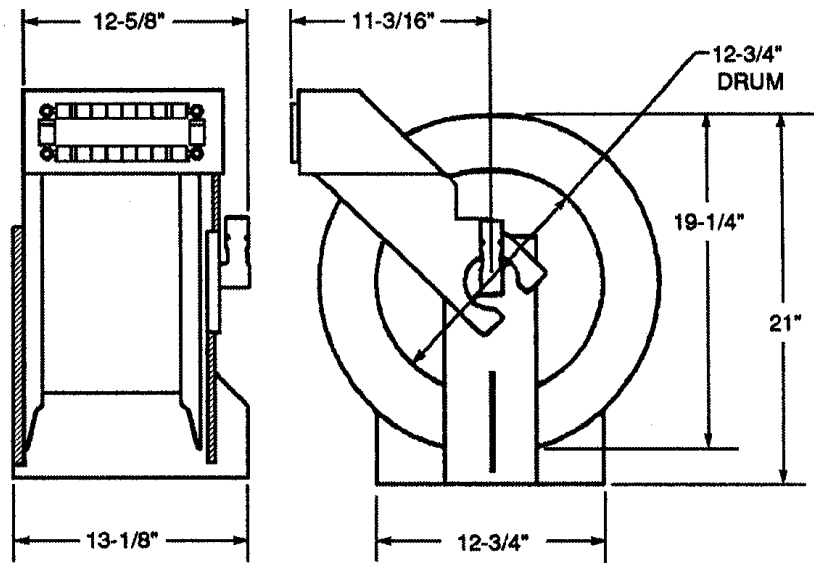

FIGURE (3) REEL INSTALLATION AND ADJUSTMENT

REEL INSTALLATION AND ADJUSTMENT

See Figure (3). The guide arm may be positioned in 22-1/2 degree increments. For ease of operation and increased hose life, the guide arm should be positioned to minimize hose strain as the delivery hose is pulled through the roller outlet.

Three studs must be used to securely attach the guide arm, it may be necessary to change the position of the hex head screw and one stud in order to obtain the desired guide arm position.

The hose clamp must be relocated if the guide arm is repositioned.

SAFETY INFORMATION

Read and understand all warnings, cautions and instructions before operating this equipment. Extreme caution should be used when operating this equipment as personal injury and/or property damage can result from equipment misuse. Adequate personal protection is recommended to prevent splashing of material on the skin or in the eyes. ALWAYS disconnect air coupler from pump when the pump is not being used.

PRESSURE RELIEF PROCEDURE

Always perform this procedure when the pump is shut off and before checking, servicing, installing, cleaning or repairing any part of this system.

Perform the following procedure:

- A. Disconnect the air supply to the pump.
- B. Point the dispensing valve away from yourself and others.
- C. Open the dispensing valve into an appropriate container until the pressure is relieved.

If the above procedure does not relieve the pressure, the dispensing valve or hose may be restricted. To relieve the pressure, very slowly loosen the hose end coupling. Then loosen completely and clear the dispensing valve and/or hose.

INSPECTION

Prior to operation or maintenance a visual inspection shall be made. Check reelsystem for leaks, worn or missing parts.

Any reel that appears to be damaged in any way, is badly worn or operates abnormally shall be removed from use until repairs are made. Contact factory authorized service center for repairs.

If overpressurizing of the equipment is believed to have occurred, contact a factory authorized service center for inspection of the reel.

Annual inspection by a factory authorized service center is recommended.

DISASSEMBLY

To disassemble, perform ASSEMBLY procedures in reverse.

REPAIR

Repair is limited to replacement of listed service parts. Special procedures and tools are required. Contact LincolnCustomer Service, One Lincoln Way, St. Louis, MO 63120-1578, (314) 679-4200 for your nearest authorized service center.

When ordering replacement parts, list: part number, description, model number and series number.

LIMITED WARRANTY

Lincoln warrants that lubrication equipment, materials dispensing equipment and other related equipment manufactured by it will be free from defects in material and workmanship during the one (1) year following the date of purchase. If equipment proves to be defective during this warranty period, it will be repaired or replaced without charge, provided that factory examination **indicates the equipment to be defective. To obtain repair or replacement, it must be shipped, transportation charges prepaid, with proof of date of purchase to a Lincoln authorized Warranty and Service Center, within the one (1) year following the date of purchase.**

This warranty is extended to the original retail purchaser only. This warranty does not apply to equipment damaged from accident, overload, abuse, misuse, negligence, faulty installation or abrasive or corrosive materials, or to equipment repaired or altered by anyone not authorized by Lincoln to repair or alter the equipment. This warranty applies only to equipment installed and operated according to the recommendations of Lincoln or its authorized field personnel.

No other express warranty applies to lubrication equipment, materials dispensing equipment, and other related equipment manufactured by Lincoln. ANY IMPLIED WARRANTIES applicable to lubrication equipment, materials dispensing equipment, and other related equipment manufactured by Lincoln INCLUDING THE WARRANTIES OF MERCHANTABILITY AND FITNESS FOR A PARTICULAR PURPOSE, WILL LAST ONLY FOR ONE (1) YEAR FROM THE DATE OF PURCHASE. SOME STATES DO NOT ALLOW LIMITATIONS ON HOW LONG AN IMPLIED WARRANTY LASTS, SO THE ABOVE LIMITATION MAY NOT APPLY TO YOU.

In no event shall Lincoln be liable for incidental or consequential damages. The liability of Lincoln on any claim for loss or damage arising out of the sale, resale, or use of lubrication equipment, materials dispensing equipment, and other related equipment shall in no event exceed the purchase price. SOME STATES DO NOT ALLOW THE EXCLUSION OR LIMITATION OF INCIDENTAL OR CONSEQUENTIAL DAMAGES, SO THE ABOVE LIMITATION OR EXCLUSION MAY NOT APPLY TO YOU.

THIS WARRANTY GIVES YOU SPECIFIC LEGAL RIGHTS AND YOU MAY ALSO HAVE OTHER RIGHTS WHICH VARY FROM STATE TO STATE.

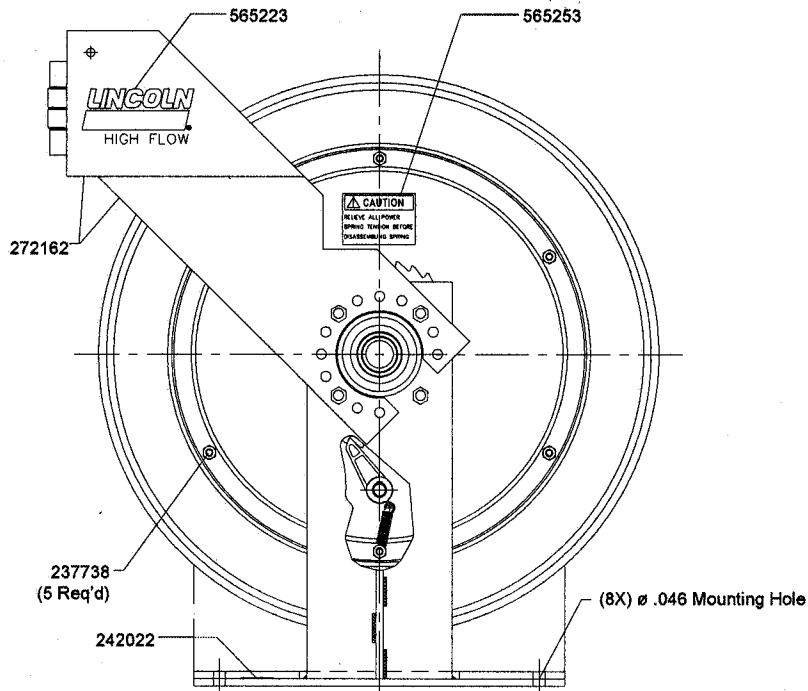
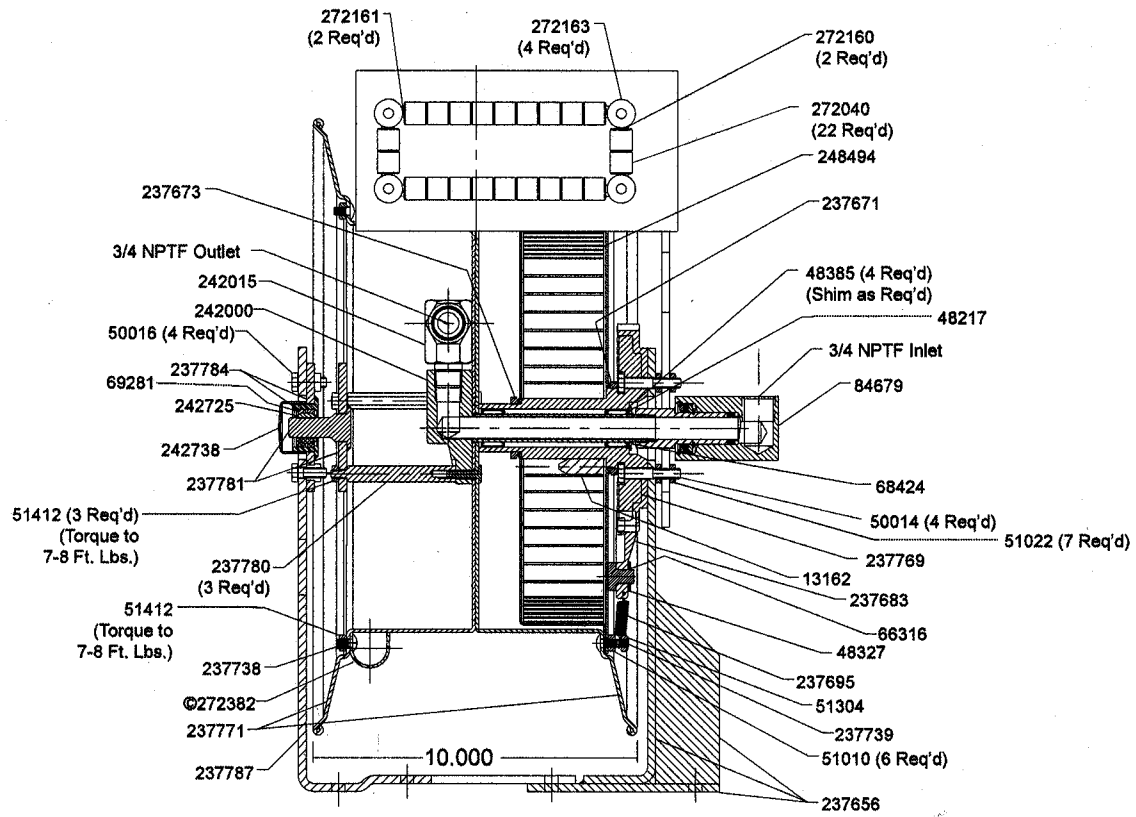

SERVICE PARTS (CONT)

PART	QTY	DESCRIPTION	PART	QTY	DESCRIPTION
13162	1	Pin .405 x 1-1/8	237771	1	Sheave
48217	1	Gland Pkg Washer	237780	3	Standoff
48327	1	Washer, Pkg. .915 OD	237781	1	Axle, Outboard Weld
48385	4	Washer, Shim 1-3/8	237784	1	Outboard Bearing Assembly
50014	4	SCR HHCS 5/16-18 x 1-3/4	237787	1	Support, Outboard
50016	4	Screws	242000	1	Axle, High Flow
50757	4	SCR HHCS 1/4-20 x 5/8	242015	1	Adapter, Swivel
51022	7	Jam Nut	242022	1	Label, Nameplate
51304	1	Lock Nut	242505	1	Nipple, Formed
51412	10	Nut, Hex 1/4-20 GR5	242506	1	Elbow, 3/4 FPT x 45
66316	1	Ring, Retaining	242725	1	Bearing, Special
68340	1	Decal, Instr	242738	1	Cap, Vinyl 1.5 ID BL
68424	1	Ring, Retaining EXT TRU	248494	1	Spring, Power Assembly
69281	1	Retaining Ring	272040	22	Roller
84679	1	Swivel Assembly	272160	2	Pin
237656	1	Support Weld't	272161	2	Pin
237671	1	Pkg, V-Ring 2.68 OD	272162	1	Arm Roller Support Assy
237673	1	Pkg, V-Ring 1.82 OD	272163	4	Retainer, Shaft
237683	1	Pawl, Latch	272382	1	Clamp, Hose (for 3/4" ID Hose)
237695	1	Spring, Extension	565223	1	Label, Logo Lincoln
237738	6	Bolt, Carriage 1/4-20 x 1/2 GR5	565253	1	Label, Caution
237739	1	Bolt, Carriage 1/4-20 x 1 GR5	565256	2	Label, Capacity
237769	1	Arbor and ratchet casting	565262	1	Label, Caution

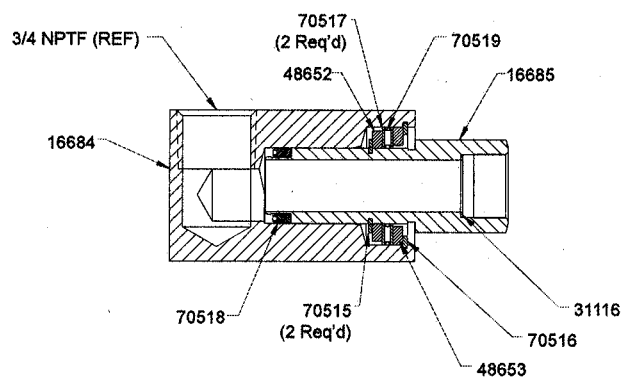
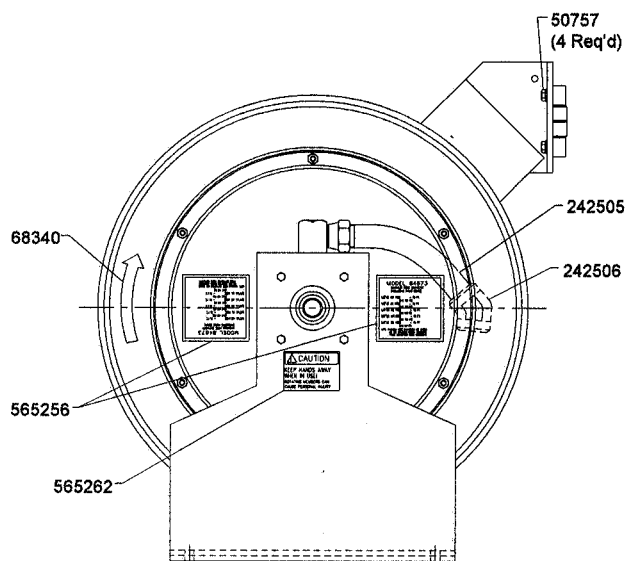

84679 Swivel Assembly
 Assemble to Axle with Loctite 242.
 Torque to 50 Ft. Lbs.

Lincoln Industrial Standard Warranty

LIMITED WARRANTY

Lincoln warrants the equipment manufactured and supplied by Lincoln to be free from defects in material and workmanship for a period of one (1) year following the date of purchase, excluding therefrom any special, extended, or limited warranty published by Lincoln. If equipment is determined to be defective during this warranty period, it will be repaired or replaced, within Lincoln's sole discretion, without charge.

This warranty is conditioned upon the determination of a Lincoln authorized representative that the equipment is defective. To obtain repair or replacement, you must ship the equipment, transportation charges prepaid, with proof of purchase to a Lincoln Authorized Warranty and Service Center within the warranty period.

This warranty is extended to the original retail purchaser only. This warranty does not apply to equipment damaged from accident, overload, abuse, misuse, negligence, faulty installation or abrasive or corrosive material, equipment that has been altered, or equipment repaired by anyone not authorized by Lincoln. This warranty applies only to equipment installed, operated and maintained in strict accordance with the written specifications and recommendations provided by Lincoln or its authorized field personnel.

THIS WARRANTY IS EXCLUSIVE AND IS IN LIEU OF ANY OTHER WARRANTIES, EXPRESS OR IMPLIED, INCLUDING, BUT NOT LIMITED TO, THE WARRANTY OF MERCHANTABILITY OR WARRANTY OF FITNESS FOR A PARTICULAR PURPOSE.

In no event shall Lincoln be liable for incidental or consequential damages. Lincoln's liability for any claim for loss or damages arising out of the sale, resale or use of any Lincoln equipment shall in no event exceed the purchase price. Some jurisdictions do not allow the exclusion or limitation of incidental or consequential damages, therefore the above limitation or exclusion may not apply to you.

This warranty gives you specific legal rights. You may also have other rights that vary by jurisdiction.

Customers not located in the Western Hemisphere or East Asia: Please contact Lincoln GmbH & Co. KG, Walldorf, Germany, for your warranty rights.

Lincoln Industrial Special Limited Warranties

SPECIAL LIMITED 2 YEAR WARRANTY-

SL-V Series, Single Injectors-85772, 85782, and Replacement Injectors-85771, 85781

Lincoln warrants the SL-V Injector series to be free from defects in material and workmanship for two (2) years following the date of purchase. If an injector model (single or replacement) is determined to be defective by Lincoln, in its sole discretion, during this warranty period, it will be repaired or replaced, at Lincoln's discretion, without charge.

SPECIAL LIMITED 5 YEAR WARRANTY-

Series 20, 25, 40 Bare Pumps, PMV Bare Pumps, Heavy Duty and 94000 Series Bare Reels

Lincoln warrants series 20, 25, 40 bare pumps, PMV bare pumps, Heavy Duty (82206), Mini Bench (81133, 81323), and 94000 LFR series (94100, 94300, 94500) bare reels to be free from defects in material and workmanship for five (5) years following the date of purchase. If equipment is determined by Lincoln, in its sole discretion, to be defective during the first year of the warranty period, it will be repaired or replaced at Lincoln's discretion, without charge. In years two (2) and three (3), the warranty on this equipment is limited to repair with Lincoln paying parts and labor only. In years four (4) and five (5), the warranty on this equipment is limited to repair with Lincoln paying for parts only.

SPECIAL LIMITED 5 YEAR WARRANTY-

LFM Series Oil Meters (Lincoln Fluid Meter), LFV (Lincoln Fluid Valves), AOD (Air-Operated Diaphragm Pumps)-

Lincoln warrants the LFM meter series (908/912 series), the Lincoln Fluid valve (708/712 series), our Universal Inline Digital Meters (812/813 series), and our AOD Pump offering to be free from defects in material and workmanship for five (5) years following the date of purchase. If either is determined to be defective by Lincoln, in its sole discretion, during the warranty period, they will be repaired or replaced, at Lincoln's discretion, without charge.

Lincoln Industrial Contact Information

To find Lincoln Industrial's Nearest Service Center

Call one of the following numbers, you may also use our Website

Customer Service
Website

314-679-4200
lincolnindustrial.com

Americas:
One Lincoln Way
St. Louis, MO 63120-1578
USA
Phone +1.314.679.4200
Fax +1.800.424.5359

Europe /Africa/Middle East
Lincoln GmbH
Heinrich-Hertz-Str. 2-8
69190 Walldorf - Germany
Phone/Fax +49.6227.33-0/-259
www.lincolnindustrial.de

Asia/Pacific:
No. 3 Tampines Central 1
#04-05, Abacus Plaza.
Singapore 529540
Tel +65.6588.0188
Fax +65.6588.3438

© Copyright Lincoln Industrial
Corp. 2010
Printed in USA
Web site:
www.lincolnindustrial.com