

AIR OPERATED EJECTOR

36:1 RATIO

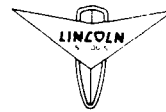

Model 84564

Series "A"

SPECIFICATIONS

Priming Pressure: 2000 psi Maximum
 Air Operating Pressure: 100 psi Maximum
 Output Per Cycle: 0.1 cu. in. to 1.0 cu. in.

TO ADJUST OUTPUT

Loosen 51014 Lock Nut and turn 16542 Adjusting Screw counter-clockwise to increase output or clockwise to decrease output. Tighten 51014 Lock Nut.

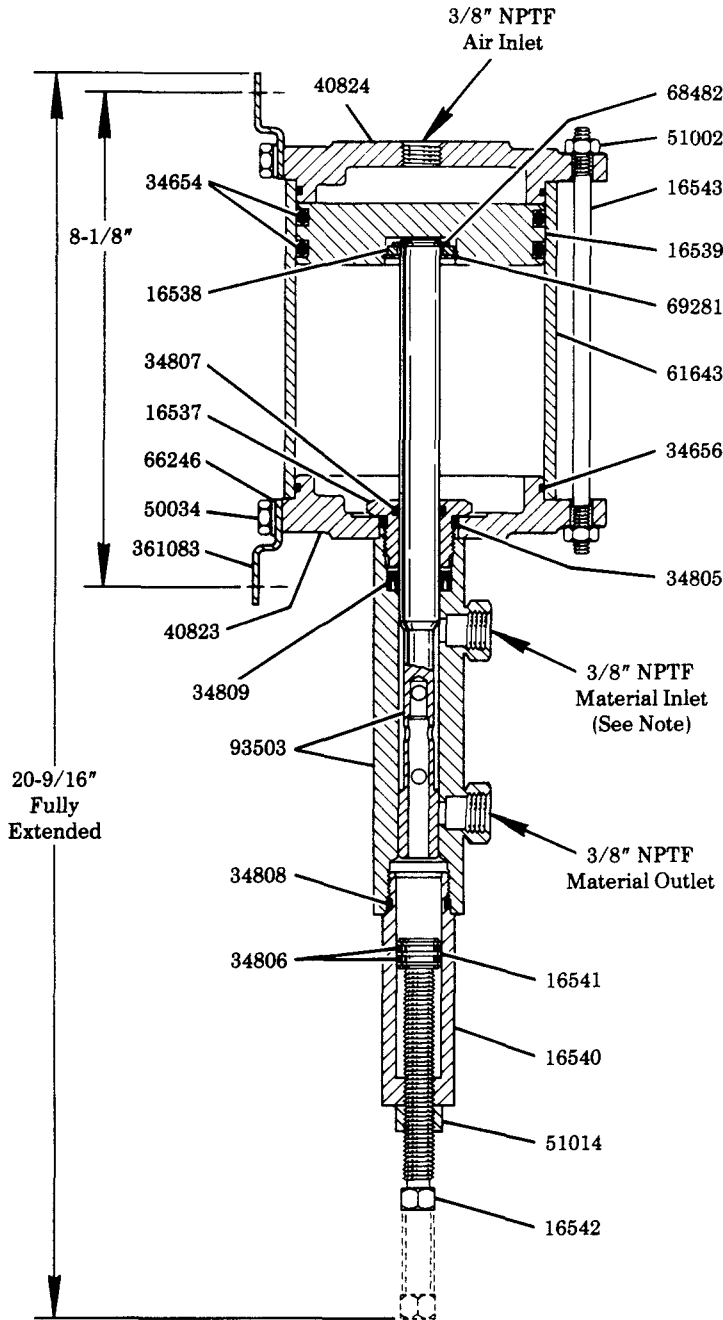

SECTION A-A

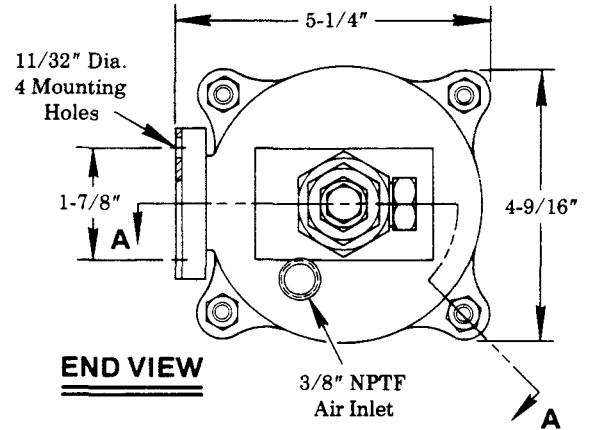

END VIEW

NOTE
 A length of hose must be used at the material inlet to prevent a hydraulic lock which may occur if rigid piping is used.

SERVICE PARTS

PART	QUAN.	DESCRIPTION
16537	1	Packing retainer
16538	1	Spacer
16539	1	Piston
16540	1	Adjustment housing
16541	1	Plunger stop
16542	1	Adjusting screw
16543	4	Tie rod
*34654	2	O-ring
*34656	2	O-ring
*34805	1	O-ring
*34806	2	O-ring
*34807	1	O-ring
*34808	1	O-ring
*34809	1	U-cup packing
40823	1	Cylinder head
40824	1	Cylinder head
50034	4	Screw
51002	8	Nut
51014	1	Lock nut
61643	1	Air cylinder
66246	4	Lockwasher
68482	1	Retaining ring
69281	1	Retaining ring
*93503	1	Body & plunger assembly
361083	2	Mounting bracket

*Recommended service parts inventory.

LINCOLN ST. LOUIS
 4010 GOODFELLOW BLVD · ST LOUIS MO 63120 · (314) 383 5900



SECTION - F40
PAGE - 27