

TEFLON KIT

FOR 83606 PUMP TUBE ASSEMBLY
SERIES "A", "B", & "C"



Model 83967

TO CONVERT PACKING GLAND

The Teflon Gland and Piston Packing Kit should be used when dispensing materials which are not compatible with the standard Polyurethane and Buna-N Packings.

STANDARD PUMP GLAND

Remove the following parts;
34403, 34423, 69281, 92114

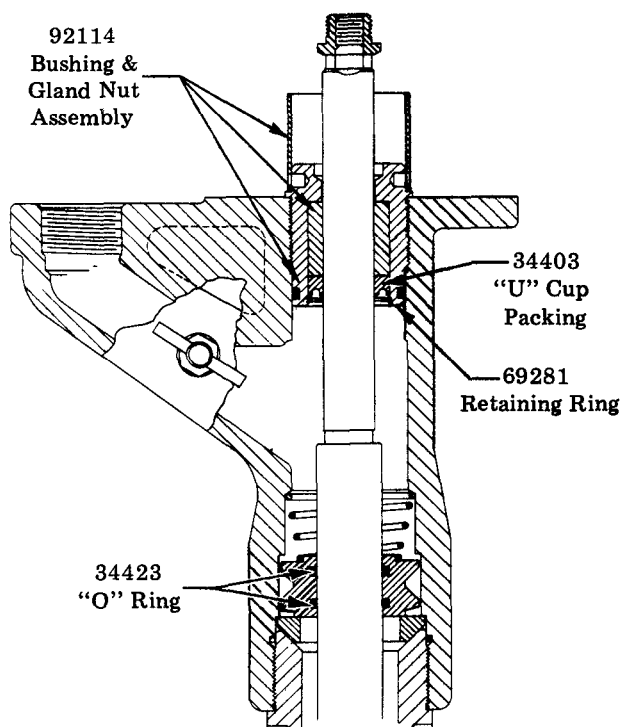

Series "A" and "B"
83606 Pump Tube Assembly

STANDARD PUMP GLAND

Remove the following parts;
34403, 34423, 34529, 69281, 92114

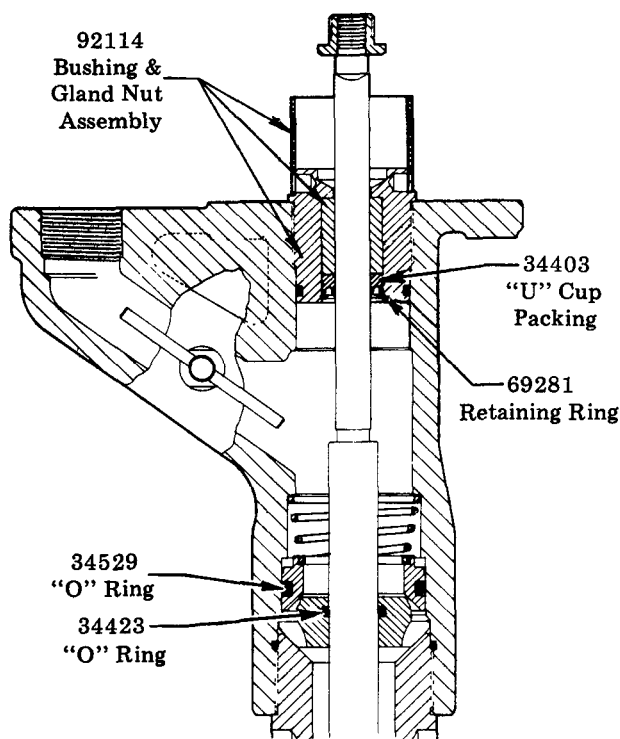

Series "C"
83606 Pump Tube Assembly

SEE REVERSE SIDE FOR
TEFLON PACKING KIT
INSTALLATION PROCEDURE

LINCOLN ST. LOUIS
4010 GOODFELLOW BLVD · ST. LOUIS, MO. 63120 · (314) 383-5900



A DIVISION OF
McNEIL
CORPORATION

SECTION **-K4**
PAGE **-17**

INSTALLATION PROCEDURE

Invert 38142 "U" Cup Packing and force over Piston Rod. (This is done to "size" the packing bore.)

Remove 38142 "U" Cup Packing from Piston Rod.

Assemble all parts included in the Gland Assembly. Do not tighten the 14747 Spreader Nut at this time.

Insert Piston Rod up through Gland Assembly and tighten the 14747 Spreader Nut.

Screw Gland and Piston Rod Assembly into Pump Outlet Casting.

Series "A" and "B"

Insert two 34538 O-Rings into upper Check Bushing and install in pump.

Series "C"

Install one 34534 on 14647 Check and install in pump.

Series "C"

Insert one 34538 O-Ring in Check Bushing and install in pump.

Re-Assemble pump tube to complete installation of "Teflon" Packing Kit.

NOTE: 34534 "O" Ring and 14647 Check must be fully depressed into outlet body before assembling lower section parts.

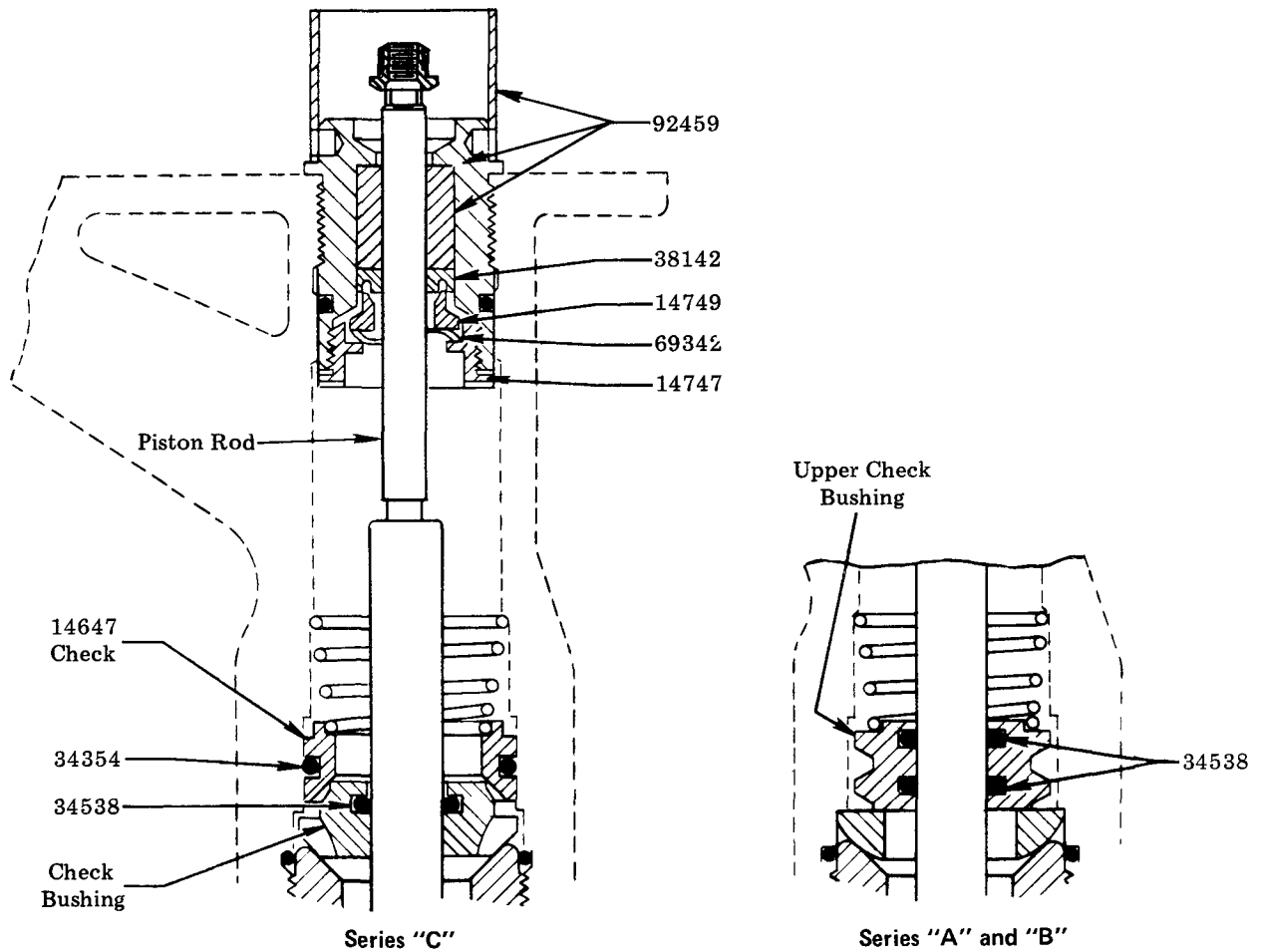

MODEL 83967

PART NO.	QUAN.	DESCRIPTION
14747	1	Spreader Nut
14749	1	Spreader
34534	1	O-Ring
34538	2	O-Ring
38142	1	U-Cup Packing
69342	1	Wave Washer
92459	1	Bushing and Gland Nut Assembly

RETAIN THIS INFORMATION FOR FUTURE REFERENCE

When ordering replacement parts, list: Part Number, Description, Model Number, and Series Letter.
 LINCOLN ST. LOUIS provides a Distributor Network that stocks equipment and replacement parts.
 A list of Authorized Service Departments will be furnished upon request.