

Lincoln installation components, accessories and lubrication fittings



LINCOLN



Miniature Air Line Combination Units

Filter-Lubricator

Part No.	Maximum Air Supply	Operating Temperature Range	Element Particle Size	Lubricator Bowl Capacity ozs. / ml
85674	150 psig / 10 bar	0° to 125°F / -18° to 52°C	5μ	1.0 / 30

Part No.	Drain Type	Port Size PTF	Dimensions - in. / mm				Weight lbs. / kg
			A	B	C	Dia.	
85674	Manual	¼"	3.25 / 83	1.98 / 50	3.66 / 93	1.45 / 37	0.9 / 0.4

Modular Air Line Equipment Accessories—Lockout Valve

Install in-line or modular with other AirCare products to help conform to OSHA Lockout Regulations. In the closed position, valves block inlet air flow and exhaust downstream air.



Part No.	For Modular use with	For In-Line use with	Maximum Air Supply	Operating Temperature Range:
247770	¼" Modular	¼"	250 psig / 17 bar	0° to 150°F / -20° to 65°C
247771	⅜" Modular	⅜"		
247772	½" Modular	½"		

Modular Air Line Equipment Accessories—Quick Clamp

Use with Modular Air Line Components to provide modular installation capability. Flanges on the products slide into "V" grooves in the quick clamp. Two face-sealing O-rings in the quick clamp provide an air tight connection when the clamp is closed.



Part No.	For Modular Sizes	Dimensions in. / mm
247782	¼" and ⅜"	1.50 / 38
247783	½" and ¾"	2.00 / 51

Modular Air Line Equipment Accessories—Quick Clamp Wall Mounting Bracket

Use with quick clamp to provide secure mounting to a wall, machine panel or other flat surface.

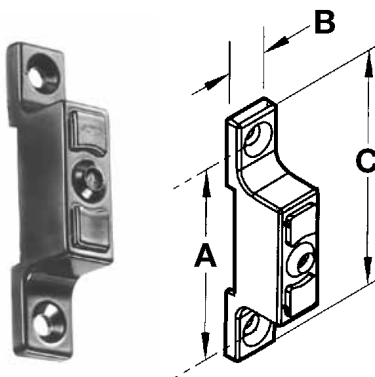

Part No.	For Modular Sizes	Dimensions - in. / mm		
		A	B	C
247792	¼" and ⅜"	2.32 / 59	0.55 / 14	2.91 / 74
247793	½" and ¾"	3.25 / 83	0.95 / 24	4.0 / 102