

# Lincoln installation components, accessories and lubrication fittings



**LINCOLN**

### Bulk Feed Line Hose and Fittings

Cut to required length and install connector fittings with standard wrenches. SAE 30R3 type hose. Temperature range -40°F to 212°F.

### Bulk Type 71900 Hose

Part No.	Size		Working Pressure	Min. Bend Radius in.	Length ft. / m
	I.D. - in.	O.D. - in.			
66844	3/16	3/8	500 psig / 34 bar	2	25 / 7.6
71900					Specify length

### Fittings for 71900 Hose

Part No.	Construction	Description	Size - in.
12613	Steel	Hose Stud	1/8 O.D. tube x 1/4 -28male
12614			1/8 NPTmale x 1/4 -28male
13003			1/4 -28male x 1/4 -28male
12720			1/8 O.D. tube x 1/4 -28male, 90° angle
* 12615		Coupling Nut	1/4 -28 female
12613-9	Type 303 Stainless Steel	Hose Stud	1/8 O.D. tube x 1/4 -28male
12614-9			1/8 NPTmale x 1/4 -28male
* 12615-9		Coupling Nut	1/4 -28 female

\* One coupling nut required for each hose stud.

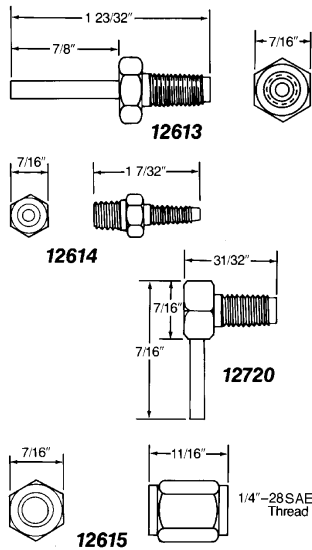

### Air Hose

Connect system to compressed air supply.

Part No.	Length ft.	Specifications			Maximum Pressure		Braid
		I.D. in.	O.D. in.	Thread in.	Working	Burst	
72024	2	1/4	5/8	1/4 NPT male	250 psig / 17 bar	1250 psig / 85 bar	2-Ply Rayon
72036	3						
72060	5						
72120	10						
72240	20						
72480	40						
72600	50	23/32	3/8 NPT male	1/2 NPT male	200 psig / 14 bar	800 psig / 55 bar	1-Ply Rayon
72024A	2						
72360A	30						
72480A	40						
72600A	50						
72720A	60	1/2	1/2 NPT male	1/2 NPT male	200 psig / 14 bar	800 psig / 55 bar	1-Ply Rayon
74024	2						
74060	5						
74480	40						
74600	50						