

GENUINE GRACO PARTS & ACCESSORIES



Air Valve Replacement Kit 239-952

For Husky™ 307 and Husky™ 715 Diaphragm Pumps

GRACO INFORMATION ENCLOSED

GRACO INC. / P.O. BOX 1441 / MINNEAPOLIS, MN 55440-1441
406-403 Rev. A September 1997 PRINTED IN U.S.A.

⚠ WARNING

For detailed instructions and warnings, see your pump instruction manual.



Ref. No.	Part No.	Description	Qty.
9	187-726	BEARING, link	1
A	235-250	VALVE, director <i>(see pump manual for parts)</i>	1
B	111-920	LUBRICANT, grease	1

1. Unscrew the six mounting screws, and remove the air valve (A) from the pump. See Fig. 1.

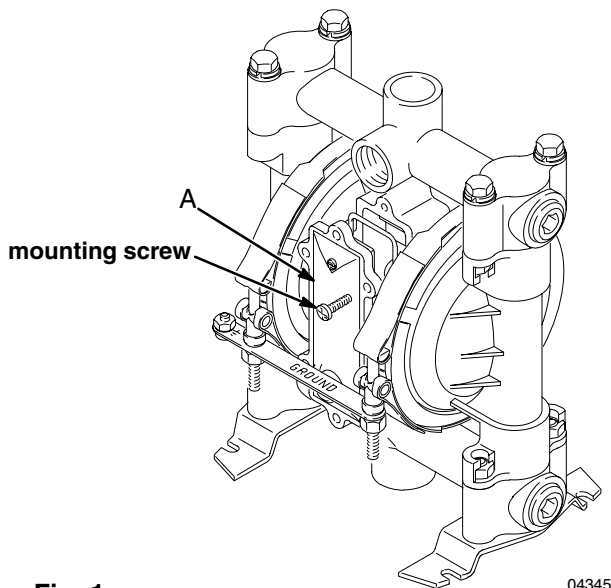

Fig. 1

04345

2. Make sure the bearings stay in place. Sometimes they stick to the air valve when it is removed. See Fig. 2.

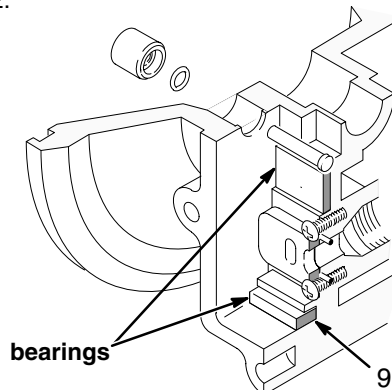

Fig. 2

04233

3. Apply grease (B) generously as shown in Fig. 3.

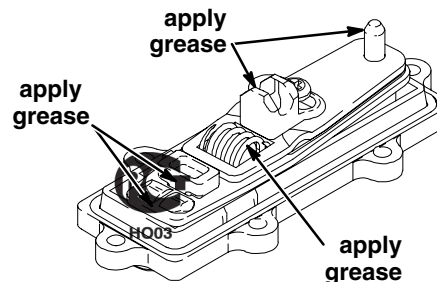



Fig. 3

03412A

4. If you are working on a Husky 307 pump, skip this step, and go to step 5. If you are working on a Husky 715 pump, you must complete the following before you proceed:
 - a. Check if either of the two pilot pins are protruding into the air valve cavity. See Fig. 4. If they are protruding, push them back in as far as possible. If one of the pins is still protruding, make sure the air valve is shifted **away from** that pilot pin's side of the air valve cavity. To shift the air valve, push down on the detent link (see Fig. 5), and slide it to the other side.
 - b. Align the new air valve assembly so the reset shaft (see Fig. 5) is at the top, and the valve is angled away from the protruding pilot pin, then slip the air valve assembly into position over the air valve cavity. **Do not force the air valve down onto the pilot pin if it is protruding. If the pilot pin is interfering with the air valve, make sure the air valve is shifted away from the pilot pin, then position the air valve assembly.**

5. Screw in the mounting screws and torque them evenly as follows:
 

 For Husky 307 pumps, torque to 14 in-lb (0.9 to 1.6 N-m).

 For Husky 715 pumps, torque to 20 to 25 in-lb (2.3 to 2.8 N-m).

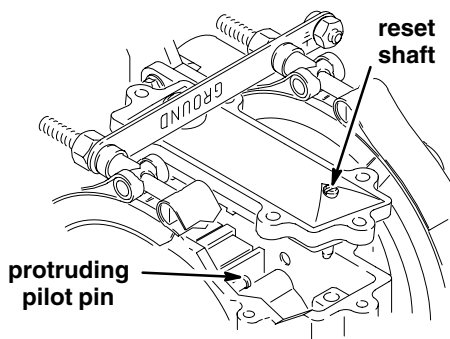

Fig. 4

05111

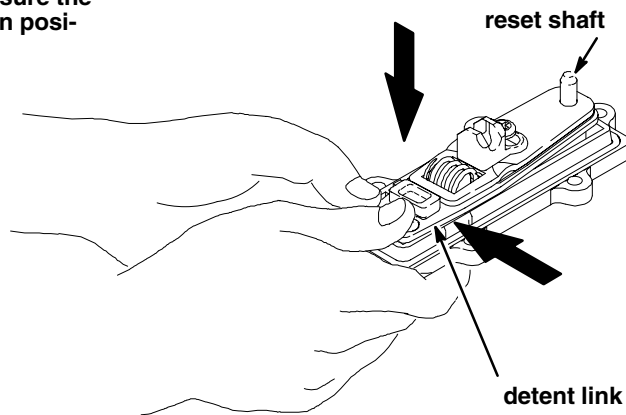

Fig. 5

05110A

All written and visual data contained in this document reflects the latest product information available at the time of publication. Graco reserves the right to make changes at any time without notice.