



THREADED FITTINGS

1/4"-28 Taper Thread Fittings

ALEMITE 1/4"-28 Taper Thread Fittings are used on most cars and trucks, as well as many industrial machines. It is recommended that SAE-LT taper threads be assembled into 1/4"-28 UNF, Class 3B, straight threaded holes having a modified maximum minor diameter of 0.2151", to ensure 75% minimum thread height.

FEATURES:

- Exceeds 72 hour salt spray test
- Dirt excluding check ball
- Trivalent zinc plating
- RoHS compliant

Product #	Type	Hex Size	Overall Length	Shank Length
1641-B	Straight	5/16"	35/64"	3/16"
1652-B	Straight	5/16"	11/16"	23/64"
1680-B	Straight	5/16"	31/32"	5/8"
1698-B	Straight	5/16"	1-1/8"	25/32"
3014-B	Straight	5/16"	1-5/8"	1"
1637-B1	45°	3/8"	13/16"	13/64"
3010-B1	65°	3/8"	25/32"	19/64"
1911-B1	90°	3/8"	3/4"	13/64"

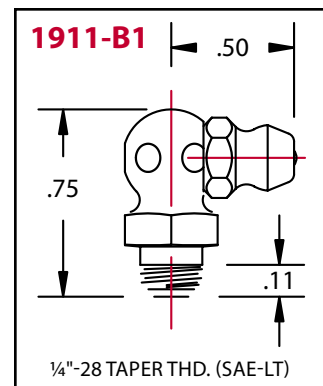
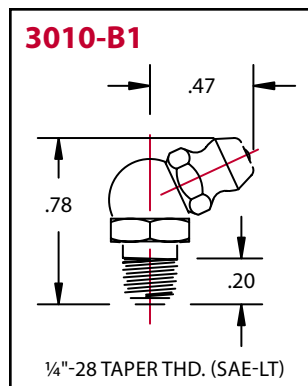
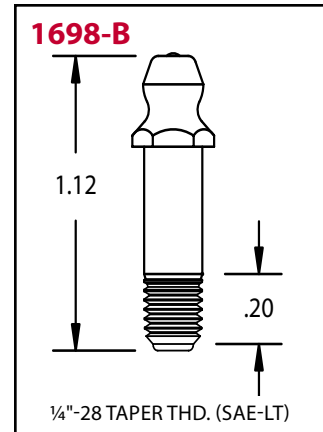
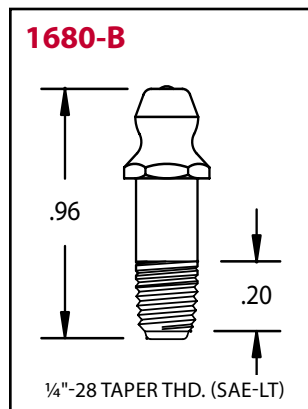
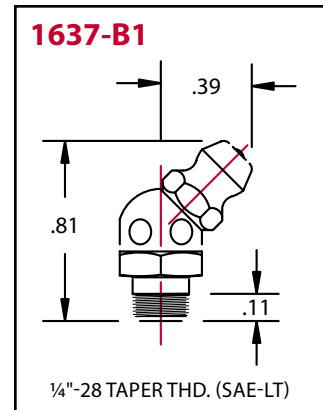
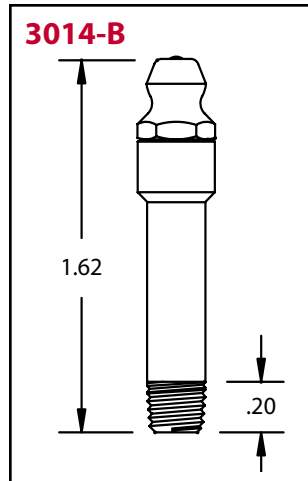
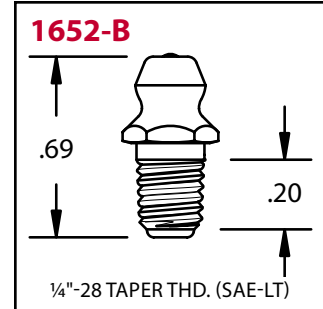
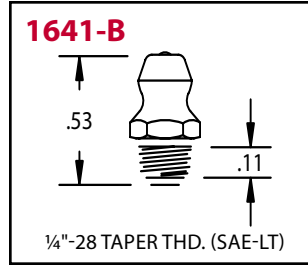



INDUSTRIAL LUBRICATION FITTINGS

FITTING ASSORTMENTS

Blister Packs

Alemite Blister Packs are packaged for display or easy storage. Each pack contains 10 fittings unless otherwise noted.

Product #	Type	Hex Size	Overall Length	Shank Length	Quantity
B1610-BL	Straight	7/16"	11/16"	19/64"	10
B1611-B	30°	7/16"	29/32"	19/64"	10
B1613-B	90°	7/16"	27/32"	19/64"	10
B1627-B	Straight	9/16"	7/8"	27/64"	5
B1629-B	67.5°	9/16"	31/32"	11/32"	5
B1637-B1	45°	3/8"	13/16"	13/64"	10
B1641-B	Straight	5/16"	35/64"	3/16"	10
B1688-B	45°	7/16"	57/64"	19/64"	10
B1911-B1	90°	3/8"	3/4"	13/64"	10
B2103	Straight	9 mm	5/8"	1/4"	10
B2105	90°	10 mm	3/4"	7/32"	10
B2106	Straight	7 mm	19/32"	1/4"	10
B2108	90°	10 mm	3/4"	7/32"	10
B2109	Straight	11 mm	5/8"	1/4"	10