

3800VR

OWNER'S MANUAL

DVR Camera



WHISTLER

WHATS INCLUDED



3800VR



**WINDSHIELD
BRACKET**



**12V CAR
ADAPTER**



USB CABLE



**OWNER'S
MANUAL**

Welcome

Thank you for choosing a Whistler product. We are dedicated to providing products that represent both quality and value. Please read the user manual carefully before using this product. If you have additional questions, please visit the FAQ page on our website at www.whistlergroup.com or call toll free 800-531-0004, 8am to 5pm CT, Monday through Friday to speak to a Customer Service Representative.

FEATURE DESCRIPTION

Features

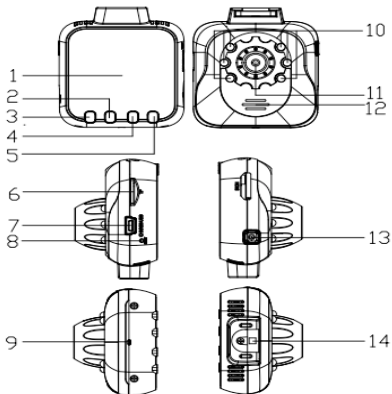

- | | | |
|-------------------|-----------------------|-----------------------|
| 1. Display Screen | 6. Micro SD Card Slot | 11. Camera Lens |
| 2. REC Button | 7. USB Interface | 12. Speaker |
| 3. UP Button | 8. RESET | 13. POWER/MODE Button |
| 4. MENU Button | 9. MIC | 14. Bracket Mount |
| 5. DOWN Button | 10. LED IR Lights | |

FEATURE DESCRIPTION

Button and Function

1. **Display Screen** - View photo and video.
2. **REC Button**
 - In Recording mode, press to start video recording, press again to stop.
 - In Photo mode, short press to take photo.
 - In MENU mode, press to select and confirm settings.
3. **UP Button**
 - In recording or photo mode, press UP to zoom in.
 - In MENU mode, press UP to scroll through menu settings.
4. **MENU** - Press button to display menu settings.
5. **DOWN Button**
 - In recording or photo mode, press DOWN to zoom out.
 - In MENU mode, press DOWN to scroll through menu settings.
6. **Micro SD Card Slot** - Slot for memory card.
7. **USB Interface**
 - Connect to PC for data transfer.
 - Connect external power to charge battery or provide working power.
8. **RESET** - Push to reset device.
9. **MIC** - Microphone for audio recording.
10. **LED IR Lights** - Infrared LED lights. A long press of the MENU button will turn the lights ON, and a star/moon icon will appear on screen. Long press MENU again to turn OFF.

FEATURE DESCRIPTION / OPERATIONS

11. **Camera Lens** - 120°wide-angle lens.
12. **Speaker**
 - Audio recording playback
 - Audible device tones.
13. **POWER / MODE Button**
 - Press to power ON/OFF
 - Short press to change from VIDEO, PHOTO, PLAYBACK modes.
14. **Bracket Mount** - Windshield Bracket attachment.

Operations

Power ON/OFF

- For ON, press and hold POWER button until the blue indicator light illuminates.

- For OFF, press and hold the POWER button until the Whistler screen appears.

NOTES:

- The 3800VR will automatically power OFF after warning of low battery.

- Refer to SPECIAL FUNCTIONS for information regarding Automatic ON/OFF.

OPERATIONS

REC Mode

- REC icon is in top left corner.
- 3800VR is recording when red dot is flashing by icon.
- Press REC button to stop or start recording.
- See FEATURE DESCRIPTION section for additional information.

PHOTO Mode

- Camera icon is in top left corner.
- Short press REC button to take picture.
- See FEATURE DESCRIPTION section for additional information.

Video/Photo Playback

- Playback icon is in top left corner.
- Press UP or DOWN to scroll through recorded files.
- Press the REC button to play the selected file.
- See FEATURE DESCRIPTION section for additional information.

OPERATIONS

MENU Settings

- Press the MENU button to see available settings for current MODE (REC, PHOTO, or PLAYBACK).
- Press UP or DOWN buttons to scroll through available settings, then press REC button to make selection.

NOTES:

- Pressing MENU button twice in any MODE (REC, PHOTO, PLAYBACK) will go to the SET menu. Use these options to adjust device settings.
- Pressing MENU after selections are made will exit MENU and return to the MODE function for selected operation.

USB Settings

Connect the the 3800VR to a computer using the USB cable included. Power ON the 3800VR to display the USB menu. Two options are available. Use UP or DOWN and REC buttons to select option.

1. **USB** - In this mode the recorded files can be accessed directly from the Micro SD card installed into the 3800VR. They can be viewed directly from the card or transferred to the computer for storage.

OPERATIONS

- 2. PC Camera** - In this mode the DVR can be selected from a computer as an attached USB device and used as a webcam (additional drivers may be required and are not included).

Battery Charging

Battery indication:



Full Battery



Slightly Low Battery



Low Battery



Battery Empty

- The 3800VR may be charged using the included 12V Car Adapter or USB cable.
- The red indicator light will be illuminated until charging is complete.

NOTE: The 3800VR is intended to be used with power being supplied with either cord included. Stand alone battery time is approximately 15 minutes.

SPECIAL FUNCTIONS

Special Functions

- G-sensor function. If a sudden shock is detected (such as in an accident) the video segment recorded is protected from being overwritten.
- Automatic power ON/OFF function when using car adapter plugged into 12V power port controlled by vehicle ignition.
- Recording starts when powered ON and stops when powered OFF with files saved.
- Seamless loop recording.
- A short press of the POWER button while recording will cause current video segment to be protected from being overwritten. A "key" icon will be seen on the screen until the next timed recording segment begins.

TROUBLESHOOTING

Can't record or take photo

Confirm that the Micro SD card is of proper class (C4 min.) and has available capacity.

"files error" appears during replay

Uncompleted files due to Micro SD card storage error. Reformat or replace card.

Video or Photo unclear

Check lens for fingerprints or other obstruction. Use a soft cloth to clean lens.

Black image when recording sky or water scene

Scenes with large contrast can influence the automatic exposure function of the 3800VR. Adjust the EV setting in MENU Settings to correct.

Color is affected on cloudy or bright outside conditions

Set the "white balance" function to automatic in MENU settings.

Cross stripe interference in image

This is caused by incorrect "Light Frequency" setting. Check setting for 50Hz or 60Hz in MENU Settings.

Reset

Operation can be restored by pushing the reset button.

SPECIFICATIONS

FEATURES	HD CAMERA, HD VIDEO RECORDING
G-SENSOR	IF A SUDDEN SHOCK IS DETECTED (SUCH AS IN AN ACCIDENT), THE VIDEO SEGMENT RECORDED IS PROTECTED FROM BEING OVERWRITTEN.
LCD SCREEN SIZE	1.5LTPS
CAMERA	120 A + GRADE HIGH-RESOLUTION ULTRA WIDE-ANGLE LENS
LANGUAGE	SUPPORTED LANGUAGES ARE LISTED IN MENU SETTINGS
FILES FORMAT	AVI
RESOLUTION	1920x1080, 1440x1080, 1280x960 1280x720, 720x480, 640x480 320x240
RECORDING VIDEO FORMAT	M-JPEG
COLOR	STANDARD
CONTINUOUS LOOP VIDEO	SEAMLESS LOOP RECORDING
AUTOMATICALLY POWER ON/OFF	WHEN USING CAR ADAPTER PLUGGED INTO 12V POWER PORT CONTROLLED BY VEHICLE IGNITION.
MOTION DETECTION	SUPPORTED
DATE / TIME FORMAT	(Y/M/D/H/M)

SPECIFICATIONS

PHOTO MODE	5 MEGAPIXELS
PHOTO FORMAT	JPEG
MEMORY CARD	MICRO SD - C4 MIN. / 32GB MAX.
MIC	BUILT IN
LED LIGHTS	INFARED
VIDEO OUTPUT	NOT SUPPORTED
VIDEO FORMAT	PAL/NTSC
CURRENT FREQUENCY	50HZ/60HZ
USB FUNCTION	1. USB-DISK 2. PC-CAMERA
POWER INPUT	5V 800MA
BATTERY	BUILT-IN 70MAH

WARRANTY INFORMATION

Consumer Warranty

This Whistler product is warranted to the original purchaser for a period of one (1) year from the date of original purchase against all defects in materials and workmanship, when purchased from an authorized Whistler retailer. **This limited warranty is void if the unit is abused, misused, modified, installed improperly, or if the housing and/or serial numbers have been removed.** There are no express warranties covering this product other than those set forth in this warranty. All express or implied warranties for this product are limited to one (1) year. *Whistler is not liable for damages arising from the use, misuse, or operation of this product including but not limited to loss of time, inconvenience, loss of use of your product or property damage caused by your product or its failure to work, or any other incidental or consequential damages including personal injury.*

DO NOT RETURN ITEM TO STORE WHERE PURCHASED.

FOR WARRANTY INFORMATION, CONTACT WHISTLER CUSTOMER SERVICE AT 1-800-531-0004.

Representatives are available to answer your questions Monday – Friday from 8:00 a.m. to 5:00 p.m. CT

Service Under Warranty

During the warranty period, defective units will be repaired or replaced (with the same or a comparable model), at Whistler's option, without charge to the purchaser when returned prepaid, with dated proof of purchase to the address below. Units returned without dated proof of purchase will be considered out of warranty and therefore are not covered by the described Limited Warranty. (Refer to Service Out of Warranty section.)

Due to the specialized equipment necessary for testing Whistler products, there are no authorized service centers other than Whistler. When returning a unit for service under warranty, please follow these instructions:

1. Ship the unit in the original carton or in a suitable sturdy equivalent, fully insured, with return receipt requested to:

Whistler Repair Dept.
1412 South 1st St.
Rogers, AR 72756

Please allow 3 weeks turnaround time.

WARRANTY INFORMATION

IMPORTANT: Whistler will not assume responsibility for loss or damage incurred in shipping. Therefore, please ship your unit insured with return receipt requested. **CODs will not be accepted!**

2. Include with your unit the following information, clearly printed:
 - Your name and physical street address for shipping (no PO Boxes), a daytime telephone number, and an email address (if applicable).
 - A detailed description of the problem (e.g., "device will not power ON").
 - A copy of your dated proof of purchase or bill of sale.
3. Be certain your unit is returned with its serial number. Units without serial numbers are not covered under warranty.

IMPORTANT: To validate that your unit is within the warranty period, make sure you keep a copy of your dated proof of purchase. For warranty verification purposes, a copy of your dated store receipt must accompany any Whistler product sent in for warranty work.

Service Out Of Warranty

Units will be repaired at "out of warranty" service rates when:

- The unit's original warranty has expired.
- A dated proof of purchase is not supplied.
- The unit has been returned without its serial number.
- The unit has been misused, abused, modified, installed improperly, or had its housing removed.

The minimum out of warranty service fee for your Whistler DVR Camera is \$35.00 (U.S.). If you require out of warranty service, please return your unit as outlined in the section "Service Under Warranty" along with a cashier's check or money order in the amount of \$35.00. Payment may also be made by MasterCard, VISA or American Express. **Personal checks are not accepted.**

WARRANTY INFORMATION

In the event repairs cannot be covered by the minimum service fee, you will be contacted by a Whistler technical service specialist who will outline options available to you.

IMPORTANT: When returning your unit for service, be certain to include a daytime telephone number and an email address (if applicable).

Customer Service

If you have questions concerning the operation of your Whistler product, or require service during or after the warranty period, please call Customer Service at **1-800-531-0004**.

Representatives are available to answer your questions Monday - Friday from 8:00 a.m. to 5:00 p.m. (CT) or visit the F.A.Q.'s at www.whistlergroup.com.

CORPORATE HEADQUARTERS

1716 SW Commerce Dr. Ste. 8

PO Box 1760

Bentonville, AR 72712

Toll Free (800) 531-0004

TEL (479) 273-6012

FX (479) 273-2927

www.whistlergroup.com

CUSTOMER RETURN CENTER

1412 South 1st St.

Rogers, AR 72756

Customer Service Tel (800) 531-0004

Email: info@whistlergroup.com

P/N 403800A

07F14 © 2014 The Whistler Group, Inc.