

SPECIAL INSTRUCTIONS

for P-190 VALVE GUIDE HONE SET

GENERAL

Sunnen P-190 Valve Guide Hone Set is designed for sizing and finishing holes in work too bulky or heavy to take to your honing machine. It uses the same mandrels and stones used in Sunnen Honing Machines. The Adapters listed in Table 1 must be used as they are different from the adapters used in Sunnen Honing Machines.

INSTALLATION

To install, proceed as follows:

1. Select correct Mandrel, Sleeve, Stone, Adapter, and Wedge and assemble to P-190 (see Table 1).
2. Mandrels used with P-190 Valve Guide Set are supplied with a standard Wedge for use in Sunnen Honing Machine. To use wedges not supplied, alter it as shown (see Figure 1).

NOTE: PBL8-W, PBL10-W, and PBL12-W Wedges (included in P-190 Kit) have already been altered.

3. Snap altered Wedge into Feed Block as shown (see Figure 2).
4. Attach Adapter to P-180 Head with 2 Capscrews (see Figure 3A, next page).

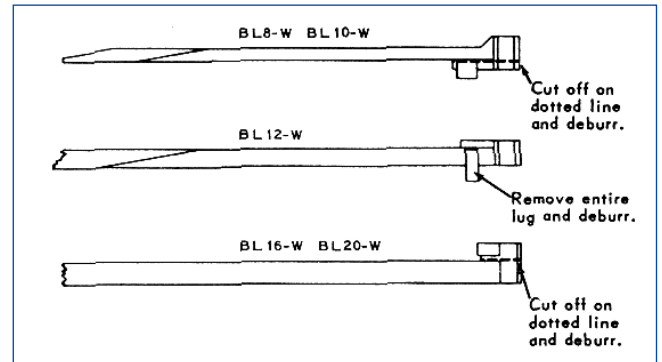

FIGURE 1

5. Insert Mandrel into Adapter with Wedge and Stone Retainer side by side and tighten setscrew (see Figure 3B, next page).
6. Place Stone in Mandrel (see Figure 3C, next page).

NOTE: If Wedge sticks out too far, retract it by turning Stone Feed-Up Knob counterclockwise (see Figure 4, next page).

INSERT ALTERED WEDGE BY PUSHING IT STRAIGHT IN AGAINST INCLINED SURFACE OF FEED BLOCK WHICH COMPRESSES SPRING CLIP AND ALLOWS WEDGE TO SNAP INTO SLOT.

TO REMOVE WEDGE, PUSH DOWN ON END AND PULL STRAIGHT OUT.

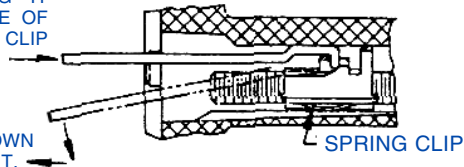

FIGURE 2

TABLE 1, Valve Guide Hone Set

NOMINAL FRACTIONAL SIZE	RANGE		1 MANDREL	2 SLEEVE	3 STONE	4 ADAPTER	5 WEDGE
	inches	millimeters					
5/16	.308-316	7.8- 8.0	BL10-308AS	S-308	L10-J69	PK10-A	BL-10W
11/32	.339-347	8.6- 8.8	BL10-339AS	S-339	L10-J69	PK10-A	BL-10W
3/8	.370-385	9.4- 9.8	BL12-370AS	S-370	L12-J67	PK12-A	BL-12W
13/32	.400-416	10.2-10.6	BL12-400AS	S-400	L12-J67	PK12-A	BL-12W
7/16	.432-447	11.0-11.4	BL12-432AS	S-432	L12-J67	PK12-A	BL-12W
1/2	.495-526	12.6-13.4	BL16-495AS	S-495	L16-J67	PK16-A	BL-16W
9/16	.557-588	14.1-14.9	BL16-557AS	S-557	L16-J67	PK16-A	BL-16W
5/8	.619-650	15.7-16.5	BL16-619AS	S-619	L20-J67	PK20-A	BL-20W
21/32	.650-681	16.5-17.3	BL16-650AS	S-650	L20-J67	PK20-A	BL-20W
11/16	.681-713	17.3-18.1	BL16-681AS	S-681	L20-J67	PK20-A	BL-20W
3/4	.744-775	18.9-19.7	BAL20-744LA*	S-744	L20-J67	PAK20-A	BL-20W

*This is a replaceable shoe type mandrel. Replacement shoe Part No. LA-C (2 required).

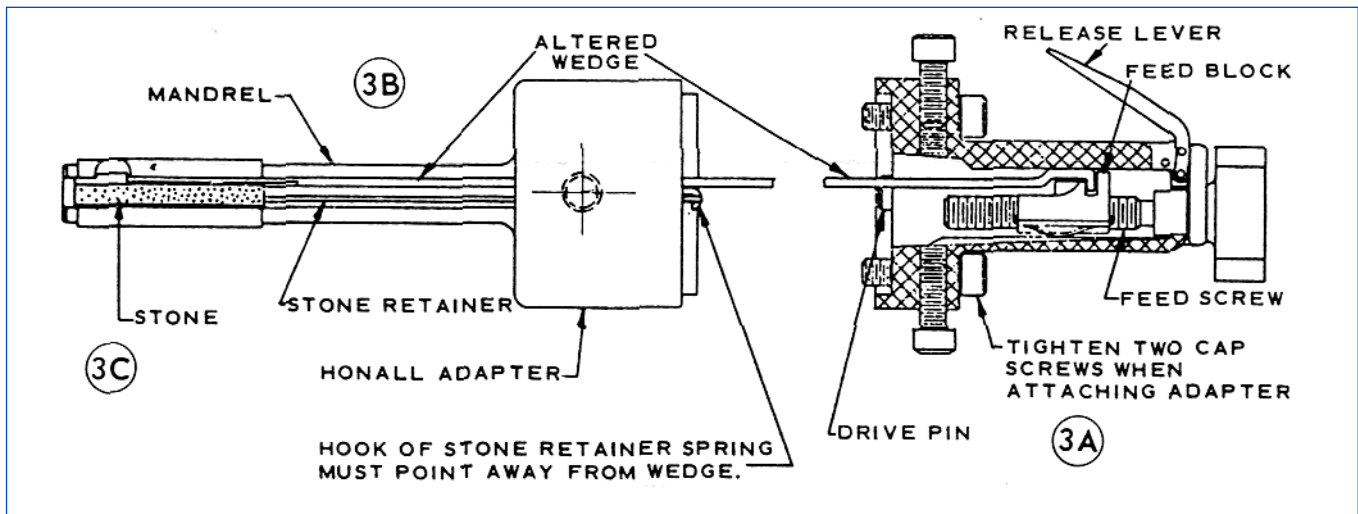

FIGURE 3

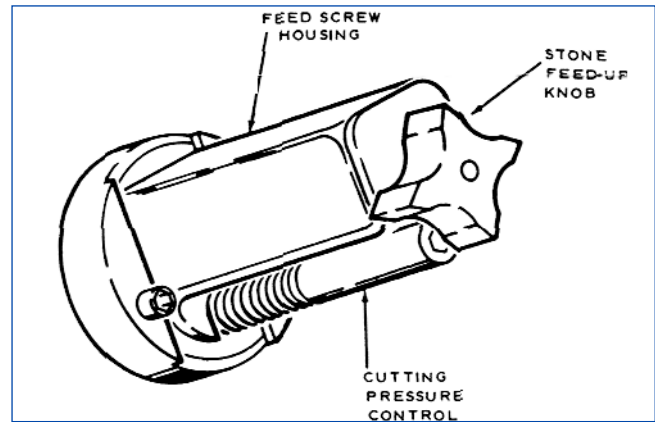

FIGURE 4

"SUNNEN® AND THE SUNNEN LOGO ARE REGISTERED TRADEMARKS OF SUNNEN PRODUCTS COMPANY."

Sunnen® reserves the right to change or revise specifications and product design in connection with any feature of our products contained herein. Such changes do not entitle the buyer to corresponding changes, improvements, additions, or replacements for equipment, supplies or accessories previously sold. Information contained herein is considered to be accurate based on available information at the time of printing. Should any discrepancy of information arise, Sunnen recommends that user verify discrepancy with Sunnen before proceeding.



SUNNEN PRODUCTS COMPANY
 7910 Manchester Road, St. Louis, MO 63143 U.S.A.
 Phone: 314-781-2100 Fax: 314-781-2268
 U.S.A. Toll-Free Sales and Service: 1-800-325-3670
 International Division Fax: 314-781-6128

<http://www.sunnen.com>
 e-mail: sunnen@sunnen.com

SWITZERLAND – SUNNEN AG
 Phone: ++ 41 71 649 33 33 Fax: ++ 41 71 649 34 34
www.sunnen.ch e-mail: info@sunnen.ch

ITALY – SUNNEN ITALIA S.R.L.
 Phone: 39 02 383 417 1 Fax: 39 02 383 417 50
www.sunnenitalia.com e-mail: sunnen@sunnenitalia.com

FRANCE – SUNNEN SAS
 Phone: +33 01 69 30 0000 Fax: +33 01 69 30 1111
www.sunnen.fr e-mail: info@sunnen.fr

BELGIUM – SUNNEN BENELUX BVBA
 Phone: +32 38 80 28 00 Fax: +32 38 44 39 01
www.sunnen.be e-mail: info@sunnen.be

UK – SUNNEN PRODUCTS LTD.
 Phone: ++ 44 1442 39 39 39 Fax: ++ 44 1442 39 12 12
www.sunnen.co.uk e-mail: hemel@sunnen.co.uk

POLAND – SUNNEN POLSKA SP. Z O.O.
 Phone: +48 22 814 34 29 Fax: +48 22 814 34 28
www.sunnen.pl e-mail: sunnen@sunnen.pl

RUSSIA – SUNNEN RUS
 Phone: +7 495 258 43 43 Fax: +7 495 258 91 75
www.sunnen.ru e-mail: sunnen@sunnen-russia.ru

CZECH REPUBLIC – SUNNEN S.R.O.
 Phone: +420 383 376 317 Fax: +420 383 376 316
www.sunnen.cz e-mail: sunnen@sunnen.cz

CHINA – SHANGHAI SUNNEN MECHANICAL CO., LTD.
 Phone: 86 21 5813 3322 Fax: 86 21 5813 2299
www.sunnensh.com e-mail: shsunnen@sunnensh.com