

# ROTATOR GR623X

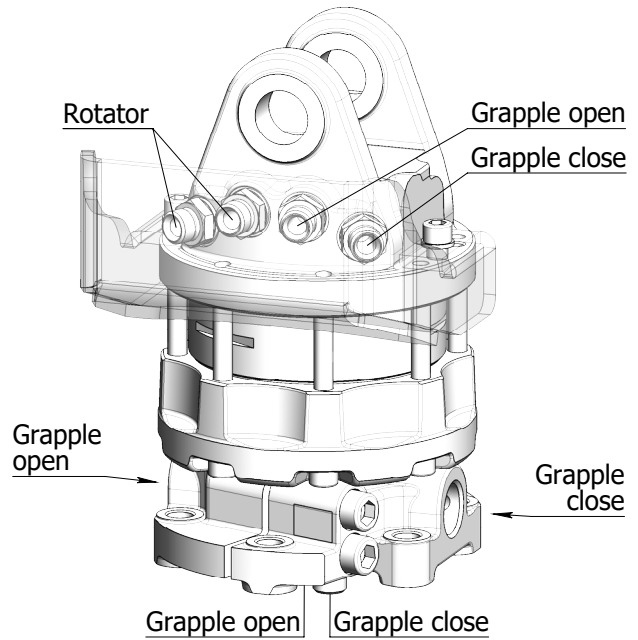
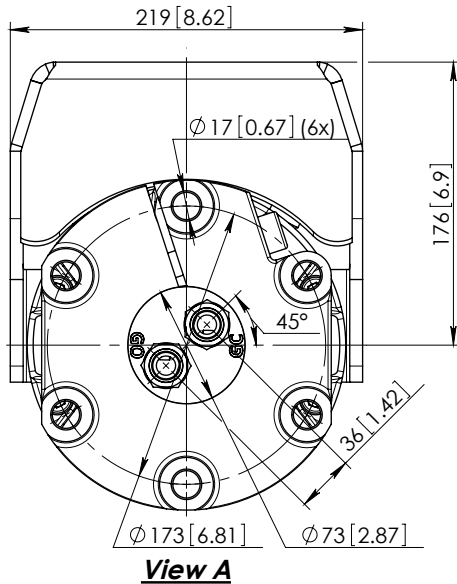
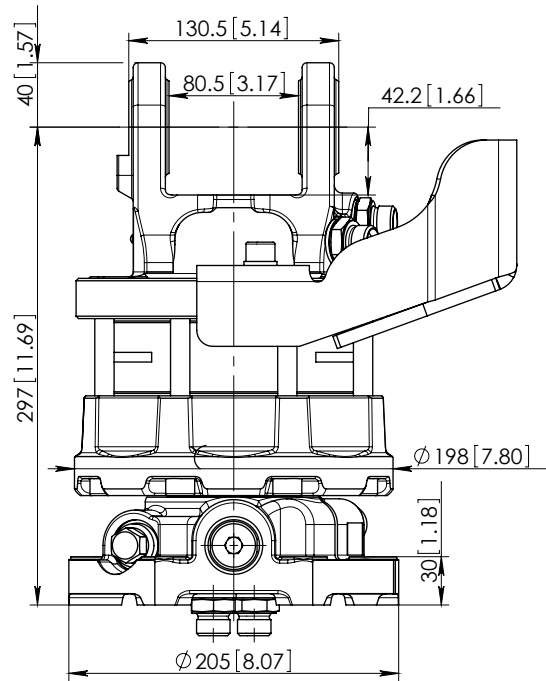
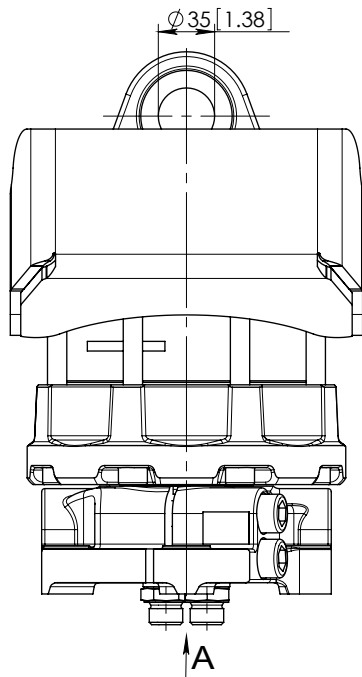

## Technical data

Rotation	Unlimited
Max axial load static, kN (lbf)	+60 (13491) - 50 (11242)
Max axial load dynamic, kN (lbf)	+30 (6745) - 25 (5621)
Torque at 25MPa (3625psi), Nm (lb ft)	2400 (1770)
Rec oilflow, l/min (US gallon)	28 (7.4)
Weight, kg (lb)	46 (101)

### Max working pressure:

Rotator	←R→	Max 25 MPa (3625 psi)	G 1/2
Grapple / Tool open	←G→	Max 20 MPa (2900 psi)	G 1/2
Grapple / Tool close	→G←	Max 30 MPa (4350 psi)	G 1/2

### Connection: