

ROTATOR GR55MFX

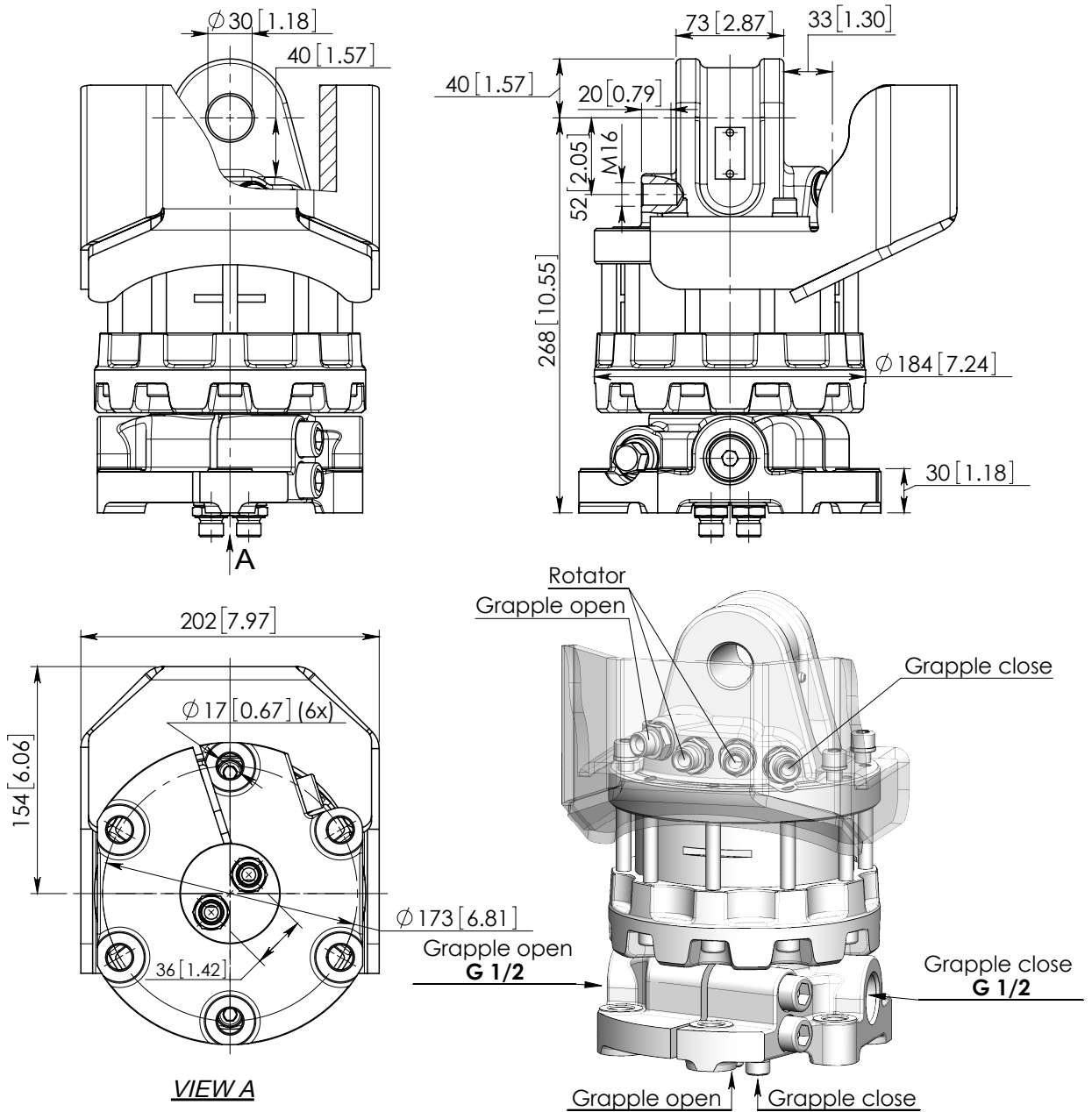

Technical data

Rotation	Unlimited
Max axial load static	55 kN [12367 lbf]
Max axial load dynamic	25 kN [5621 lbf]
Torque at 25 MPa [3625 psi]	1300 Nm [959 lb ft]
Rec oilflow	22 l/min [5.8 gal(US)/min]
Weight	36 kg [79 lb]

Max working pressure:

Rotator	↔R↔	Max 25 MPa [3625 psi]
Grapple / Tool open	↔G↔	Max 20 MPa [2900 psi]
Grapple / Tool close	→G←	Max 30 MPa [4350 psi]

Connection:

Rotator	G 3/8
Grapple / Tool open	G 3/8
Grapple / Tool close	G 3/8