

LINK BR1-A

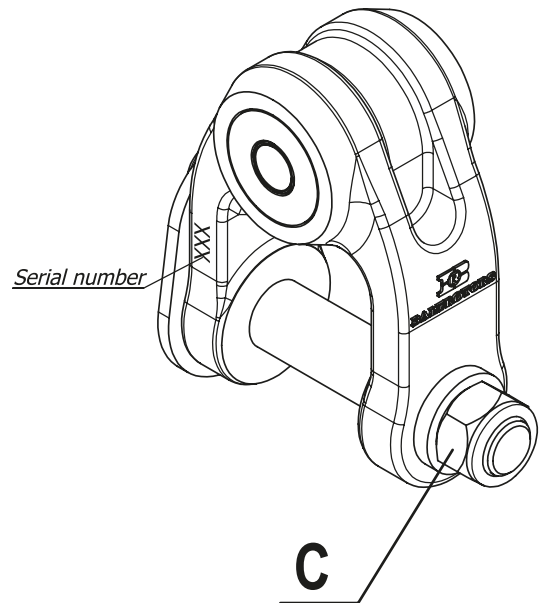
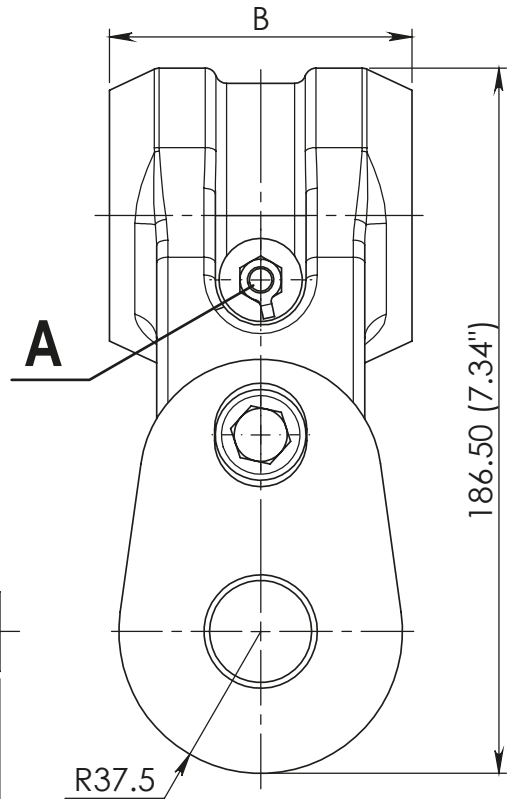
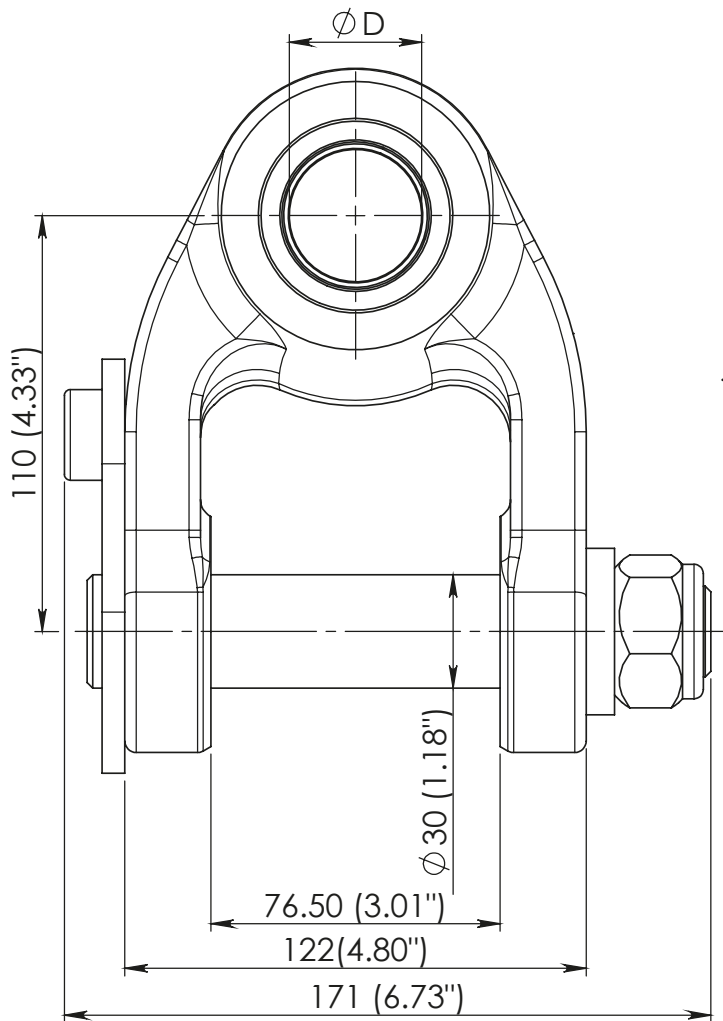

Dimensions			
Crane nose pivot pin diameter $\varnothing D$ (mm)	Link width B (mm)		
	80 ⁰ _{0.3} (3.15")	70 ⁰ _{0.3} (2.76")	60 ⁰ _{0.3} (2.36")
45 (1.77")	BR1-A/80/45	BR1-A/70/45	BR1-A/60/45
40 (1.57")	BR1-A/80/40	BR1-A/70/40	BR1-A/60/40
35 (1.38")	BR1-A/80/35	BR1-A/70/35	BR1-A/60/35
30 (1.18")	BR1-A/80/30	BR1-A/70/30	BR1-A/60/30
25 (0.98")	BR1-A/80/25	BR1-A/70/25	BR1-A/60/25
20 (0.79")	BR1-A/80/20	BR1-A/70/20	BR1-A/60/20

Max. Load - 5.5 ton (55 kN); Weight - 5.5±1 kg (12.1±2.2 lb)

Pin locking nut (C) has to be tightened with a torque of 120 Nm (89 lb ft).

Fill grease Statoil Uniway Li62 (or equivalent) through lubricating nipple (A), until it will appear to the external surfaces. Greasing must be repeated after every 8 working hours of the link.