

VFR 8T

For tractors 150-200 hp

REAR HEDGE MOWERS

VFR 8T

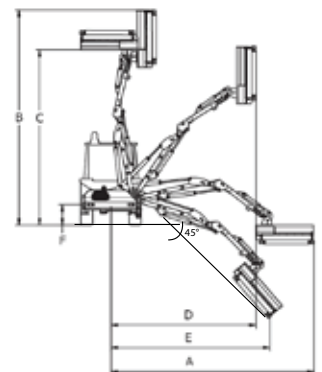

VFR 8T	8.0
A (mm)	8.000
B (mm)	8.200
C (mm)	7.100
D (mm)	7.100
E (mm)	6.200
F (mm)	550



The VFR 8T combines three important features: the parallelogram geometry, a telescopic extension and the side cabin advancement. These features are essential for an easy work in narrow spaces by long hedge mowers and all the comfort of the cutting head on the side of the cab for better visibility.

ARM MOWER

TRACTOR

Model	Extension E (mm)	Telescopic	Weight (kg)	Oil tank (L)	Head (model)	Pump (l/min)	Hydraulic Motor (HP [kW])	Power (HP [kW])	Weight (kg)	Width (m)	PTO (rpm)
DOC 800	8.000	1	1.900	260	30.5	120+20	80	150 (110)	7.000	2,5	540



P: Mechanism that allows to work flush to the wheel with long extension machines, with a very-good speed and handling quickness.



A: Machine with central advancement to the tractor, for a great visibility during work.



S: With telescopic arm/s.

TECHNICAL FEATURES AND STANDARD EQUIPMENT

- Frame in structural steel ST 52
- Highly resistant steel DOMEX700 for 1st, 2nd arm and telescopic extension terminal with hexagonal section
- Telescopic extension terminal on guide slides on ERTALON anti-wear material
- 90° rotating column and shock resistant hydraulic safety device
- Three points attachment 2nd and 3rd category
- Oil tank 260 l
- Double gear pump PARKER - 120+25 l/min
- Bidirectional hydraulic motor HP 80 power
- Biaxial prop. distributor with joystick SAUER DANFOSS
- Nitrogen accumulator for 1st arm suspension
- Rear flail head hitch
- Head rotating angle 230°
- Additional auxiliary line 3/8 "
- Self-levelling floating system
- Feeler roller recordable on 3 positions
- Helicoidal rotor with jointed cut blade M5C
- Number revs to rotor 3000 rpm
- Fixing tie-rods
- Cardan joint
- Air-oil heat exchanger with radiating mass at high thermal exchange
- Rear underrun protection with lights
- Hydraulic flail head hood
- Flail head mm 1300 MODEL 30.5 TTC 130 with belt transmission



KC4

Ø max 2 cm

standard equipment

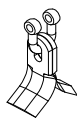

KC5

Ø max 2 cm

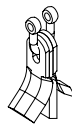

HC2

Ø max 4 cm

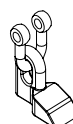

HF4

Ø max 6 cm



KF4

Ø max 4 cm



KF5

Ø max 4 cm

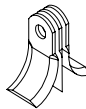

KF6

Ø max 3 cm



HF5

Ø max 6 cm



ACCESSORIES ON REQUEST

Ventilator (tractor quick couplings)

Trestle bracing

40 TTC 16 FA (1600 mm) TTC and FA included

Tie rods adapter Cat. 2 o 3

* with TTC

TERMINAL TOOLS - IN REPLACEMENT OF THE STANDARD MULCHER

BRANCH CUTTING BAR
BTZ5 15
BTZ5 18
BTZ10 16
BTZ10 19
BTZ10 22

DISC BRANCH CUTTER
DFG12
DFG15
DFG18

FOREST DISCS CUTTING BAR
BD3
BD4
BD6

DITCH CLEANER
PF80



pag. 27



pag. 28



pag. 29



pag. 30

VFR 8T



