

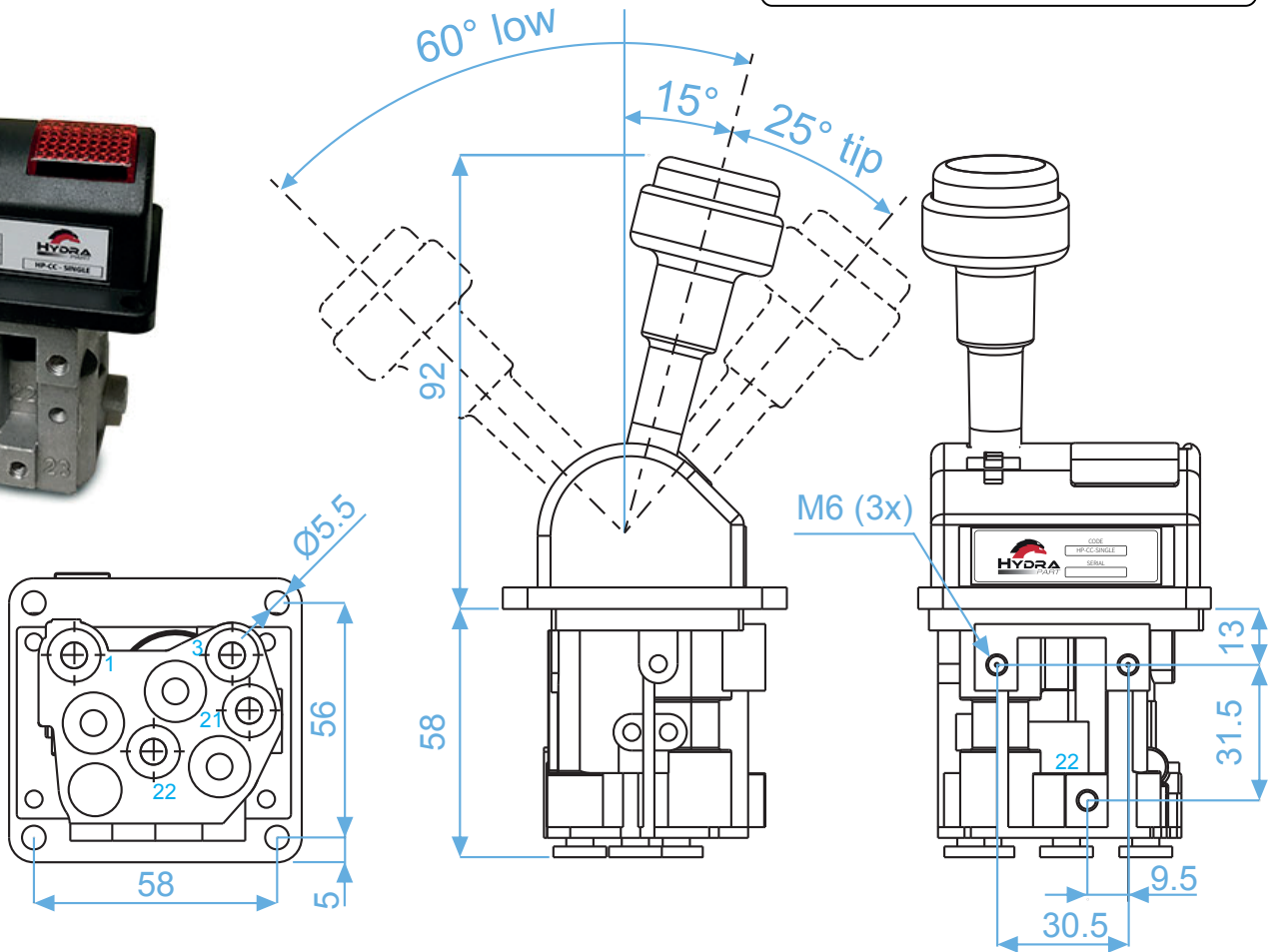

Tipper Cab Control Unit (Tip Only)

Tip only cab control used with a factory or truck manufacturer fitted PTO unit and cab mounted switch. This valve will allow a tipper body to be raised and lowered in a controlled proportional manner.

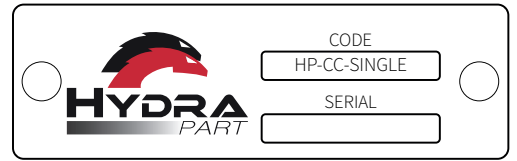

Connections

- 1 : air inlet
- 3 : air exhaust
- 21 : lowering connection (to tipping valve)
- 22 : tipping connection (to tipping valve)

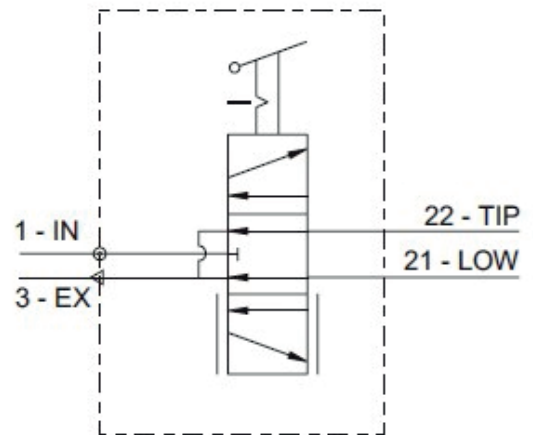

Max. press. (bar)	Min. press. (bar)	Ports			
		(1)	(3)	(21)	(22)
12 bar	5 bar	G1/8"	M5	G1/8"	G1/8"

Installation

When the air control is mounted next to the drivers seat a strong support should be used.

Always use rubber grommets to protect air tubes and to prevent that dust and water enters the cabin. For trouble free life of the entire pneumatic system the air system must be free from water.

The air control should be mounted in such a way that:

- 1 it is easy to reach by the operator.
- 2 it is no obstacle when entering or leaving the cabin.
- 3 it is clear from any moving parts such as drivers seat and closed door.

The air exhaust connection must be brought outside the cabin to prevent air entering the cabin, which gives the following disadvantages:

- 1 noise
- 2 blown up sand and dust
- 3 when alcohol is used to prevent the pneumatic system against frost the alcohol vapour will enter the cabin

Make sure that air tubes:

- 1 are not too close to sharp objects.
- 2 are clear from moving parts.
- 3 are clear from exhaust and compressor lines.
- 4 can not get kinked.
- 5 are not too long.

Note:

The air supply must always be taken from an accessory air tank or auxiliary valve and the pneumatic system must be protected with a charging valve (see guidelines from truck manufacturer)

