

TIGERGRIP | TMC 40 - 80

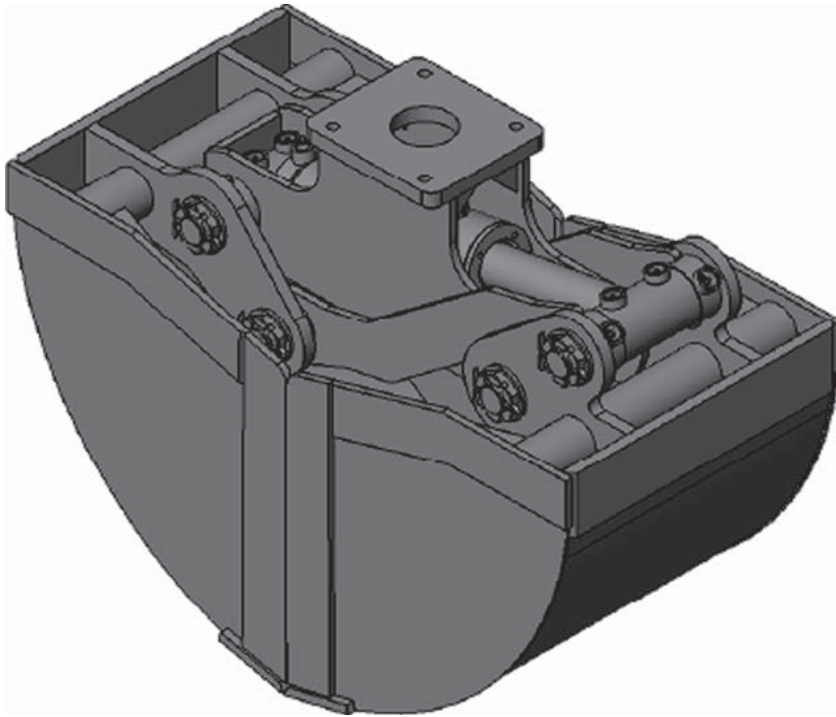

KEY FEATURES

- Double guide bars
- High tensile wear resistant steel cutting edges (500 HB)

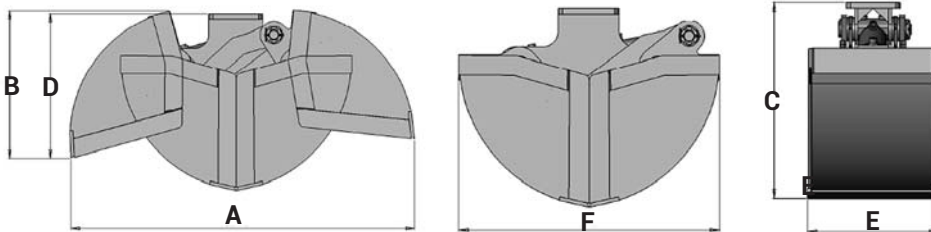

	TMC 40	TMC 50	TMC 60	TMC 80
A	1270	1270	1270	1270
B	544	544	544	544
C	650	650	650	650
D	533	533	533	533
E	435	535	635	835
F	855	855	855	855

MODEL SPECIFICATIONS



MODEL	Kg	Lt	Bar	l/min	kN	ton	tm
TMC 40	142	125	200	40	12	1	8
TMC 50	152	150	200	40	12	1	8
TMC 60	162	175	200	40	12	1	8
TMC 80	202	200	200	40	12	1	8

Approved
HYDRAULICS

Unit 15 Vauxhall Industrial Estate
Greg Street, Reddish
Stockport
SK5 7BR
United Kingdom
Telephone: 0844 770 7969
Fax: 0844 770 7979
web: www.approvedhydraulics.co.uk