

SERIE 7

For tractors 100-200 hp

BACKHOES



7.32/TI

Semi-industrial

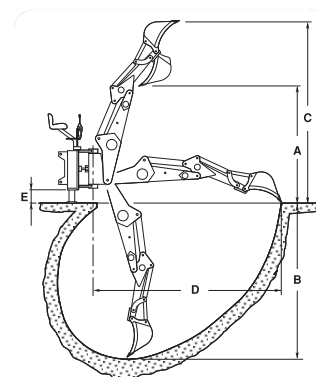

Serie 7	7.32
A (mm)	2.490
B (mm)	3.300
C (mm)	3.675
D (mm)	3.700
E (mm)	310

ARM MOWER

TRACTOR

Model	Digging depth (mm)	Rotation angle	Moving frame width (mm)	Weight (kg)	Oil tank (L)	Standard bucket (mm)	Tooth tearing resistance (kg)	Digging force with auxiliary boom (kg)
7.32/TI	3.300	180°	2.000	1.080	45	300 (30 l)	4.200	1.850

TECHNICAL FEATURES AND STANDARD EQUIPMENT

Backhoe with moving frame with hydraulic locking, applicable to the three-point hitch of the hydraulic boom.

180° central rotation by 1 cylinder (patented).

Independent hydraulic stabilisers with block valves.

Independent system with 27 cm³/rev., pump, multiplier, 59-lt built-in tank, oil strainer and hydraulic oil.

Element distributor with 60 lt/1' flow rate, control levers and built-in shock-absorbing anti-cavitation valves.

Flow rate 45 l/min.

Max working pressure: 190 bar.

Standard bucket: 300 mm.

Boom locking tensioners.

Joints with pins and bushes of case-hardened and tempered steel.

Chrome-plated double-liner cylinder rods.

Sanding and polyester powder coating.

ACCESSORIES ON REQUEST

- Installation 1: auger, grab, multipurpose fork.
 - Installation 2: hydraulic hammer, ditch cleaning titling buckets 45°(installation 1 included).
 - Installation 3: Hydraulic rotator + multipurpose fork or Grab°(installation 2 included).
 - Installation 4: hydraulic mulcher (installation 3 included).
- Pag. 76
- Hydraulic mulcher 800 mm T1 80 REV. Pag. 76
 - Remote control on the cab. Pag. 75
 - Skid steer loader application. Pag. 75
 - Hitch coupler for articulated backhoe-loader, backhoe loader, telescopic.

BUCKET	DITCH CLEANING BUCKET	45° TITLING BUCKET	TRAPEZOIDAL BUCKET	GRAB
250 mm	800 mm	800 mm	740 mm	175 dm ³
300 mm	1000 mm	1000 mm		
400 mm	1200 mm	1200 mm		
500 mm				
600 mm				
600 mm				



MULTIPURPOSE FORK
800 mm

HYDRAULIC ROTATOR
BR35

HYDRAULIC HAMMER
96 kg

AUGER
TR2

DRILL BITS (Ø x lg.1000 mm)
150
200
250
300
400

