

SERIE 7S

For tractors 120-200 hp

BACKHOES

7S

Industrial

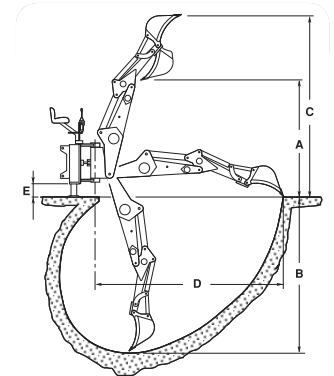

Serie 7S	
A (mm)	3.780
B (mm)	4.650
C (mm)	4.820
D (mm)	5.210
E (mm)	310

ARM MOWER

TRACTOR

Model	Digging depth (mm)	Rotation angle	Moving frame width (mm)	Weight (kg)	Oil tank (L)	Standard bucket (mm)	Tooth tearing resistance (kg)	Digging force with auxiliary boom (kg)
7S	4.650	180°	2.000	1.190	45	300 (30 l)	5.135	1.800

TECHNICAL FEATURES AND STANDARD EQUIPMENT

Backhoe with moving frame with hydraulic locking, applicable to the three-point hitch of the hydraulic boom.

180° central rotation by 1 cylinder (patented).

Independent hydraulic stabilisers with block valves.

Independent system with 27 cm³/rev., pump, multiplier, 59-lt built-in tank, oil strainer and hydraulic oil.

Element distributor with 60 lt/1' flow rate, control levers and built-in shock-absorbing anti-cavitation valves.

Flow rate 45 l/min.

Max working pressure: 190 bar.

Standard bucket: 300 mm.

Boom locking tensioners.

Joints with pins and bushes of case-hardened and tempered steel.

Chrome-plated double-liner cylinder rods.

Sanding and polyester powder coating.

ACCESSORIES ON REQUEST

- Installation 1: hydraulic mulcher. Pag. 76
- Hydraulic mulcher 800 mm T1 80 REV. Pag. 76

SPECIAL EQUIPMENT

- Special equipment: uprated pump 70 l/min, electric switch, distributor with 8 elements, two 1/2" additional lines at the jib end.

BUCKET	DITCH CLEANING BUCKET	45° TITLING BUCKET	TRAPEZOIDAL BUCKET	GRAB
250 mm	800 mm	800 mm	740 mm	³ 175 dm
300 mm	1000 mm	1000 mm		
400 mm	1200 mm	1200 mm		
500 mm				
600 mm				
600 mm				



MULTIPURPOSE FORK
800 mm

HYDRAULIC ROTATOR
BR35

HYDRAULIC HAMMER
96 kg

AUGER
TR2

DRILL BITS (Ø x lg.1000 mm)
150
200
250
300
400

