

TIGERGRIP / TG 42 ST

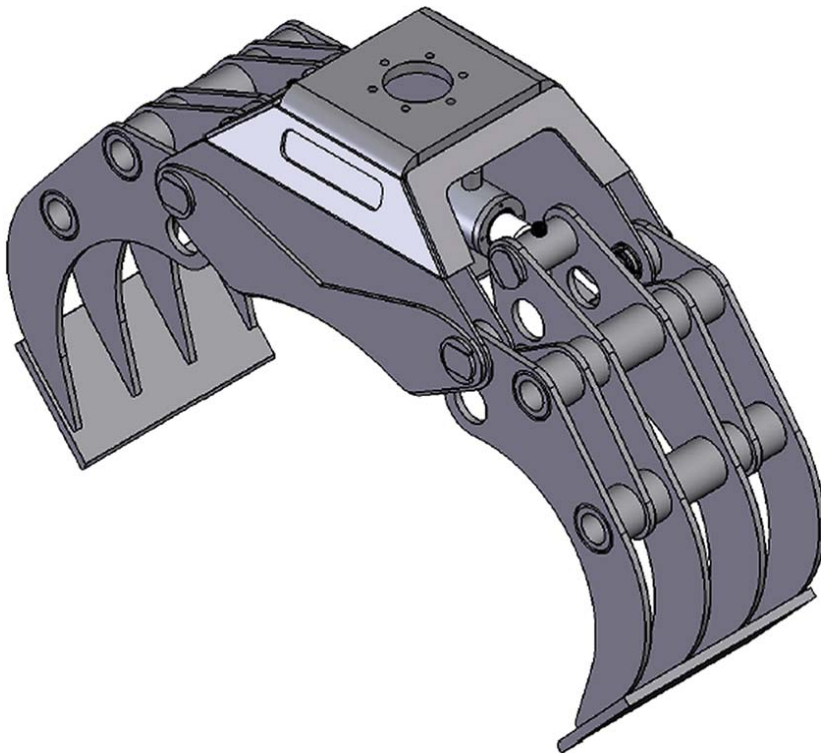

KEY FEATURES

- Heavy duty
- Double guide bars
- High pressure cylinder with double piston rod seals
- High tensile wear resistant steel (400 HB)
- Extra reinforced body for rigid mounting - excavator design
- High tensile wear resistant steel cutting edges (500 HB)

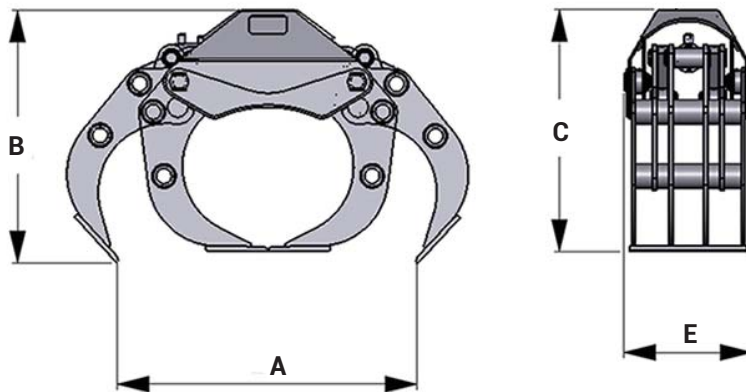

A	1750
B	1057
C	1008
E	533

MODEL SPECIFICATIONS



TG 42 ST	440	0,40	300	90	25	20	8	20	14			
----------	-----	------	-----	----	----	----	---	----	----	--	--	--



Call for advice on: 0844 770 7969 e-mail us: sales@approvedhydraulics.co.uk