

# TIGERGRIP / TG 16 ST

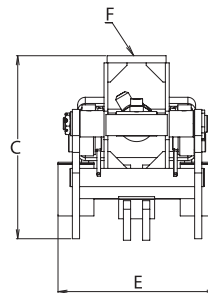

## KEY FEATURES

- Heavy duty
- Double guide bars
- Optimized roll in/roll out properties
- High tensile wear resistant steel (400 HB)
- Extra reinforced body for rigid mounting - excavator design

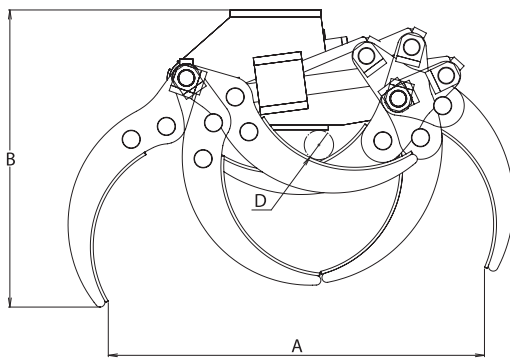

<b>A</b>	785
<b>B</b>	520
<b>C</b>	387
<b>D</b>	55
<b>E</b>	330
<b>F</b>	140x140

## MODEL SPECIFICATIONS



TG 16 ST	65	0,16	200	40	9	3	1	3	2		
----------	----	------	-----	----	---	---	---	---	---	--	--

# INTERMERCATO

High performance lift and load attachments for Forestry, Transport, Construction and Recycling.

