

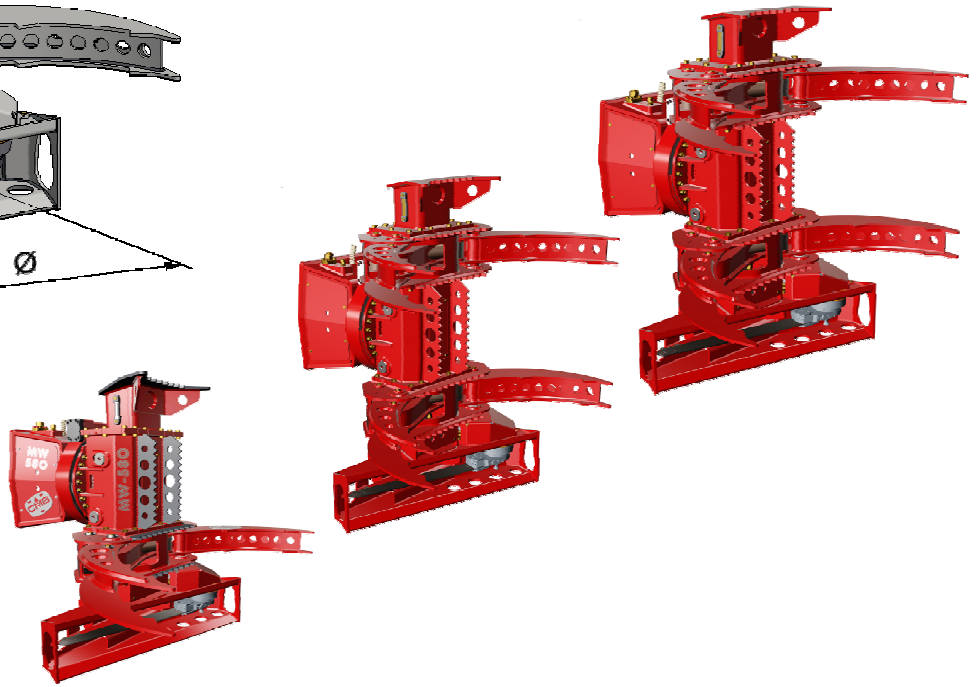

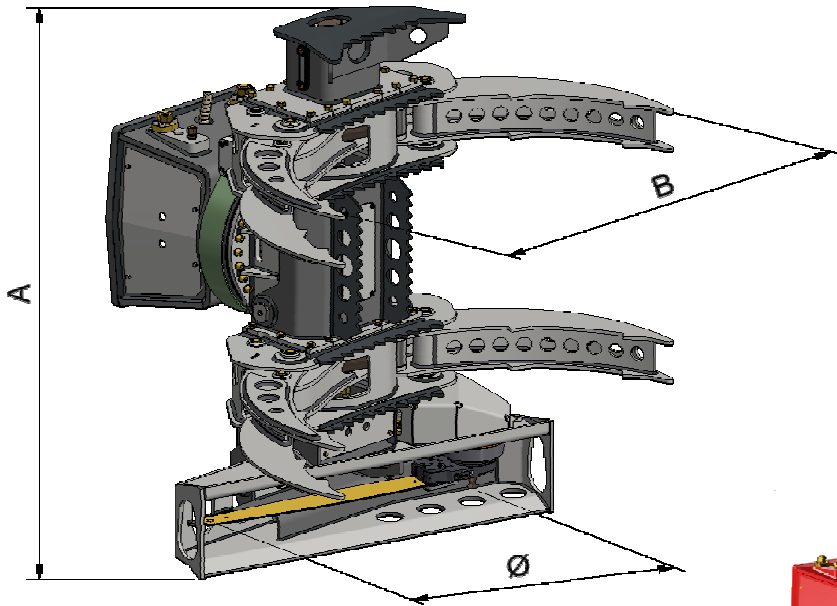



# MW Series

## DEFORESTATION GRAPPLE SAW



		MW - 580 Short T	MW - 580 Short E	MW - 580	MW - 780
	ton.	10 - 20	10 - 20	14 - 22	20 - 28
Softwood, max width	mm	580	580	580	750
Hardwood, max width	mm	580	580	580	750
(A) Height	mm	1600	1600	1850	2100
(B) Caliper Opening Width	mm	1450	1450	1450	1600
(Ø) Saw Length	mm	900	900	900	1200
Continuous Rotation		360°	360°	360°	360°
Trim Function for Cutting		Optional	Optional	Automatic	Automatic
Suspension		Active	Active	Active	Active
Lubricant		Oil	Oil	Oil	Oil
	Kg	1000	900	1260	1600
	bar	250	250	250	250
	l/min	110 - 150	110 - 150	110 - 150	140 - 170
	bar	175	175	175	175
	l/min	50 / 70	50 / 70	50 / 70	50 / 70
Solenoid Voltage	V	*	*	12	12

T= Telescopic Charger

E= Excavator