



MC - SB



MC 20 SB R

MC

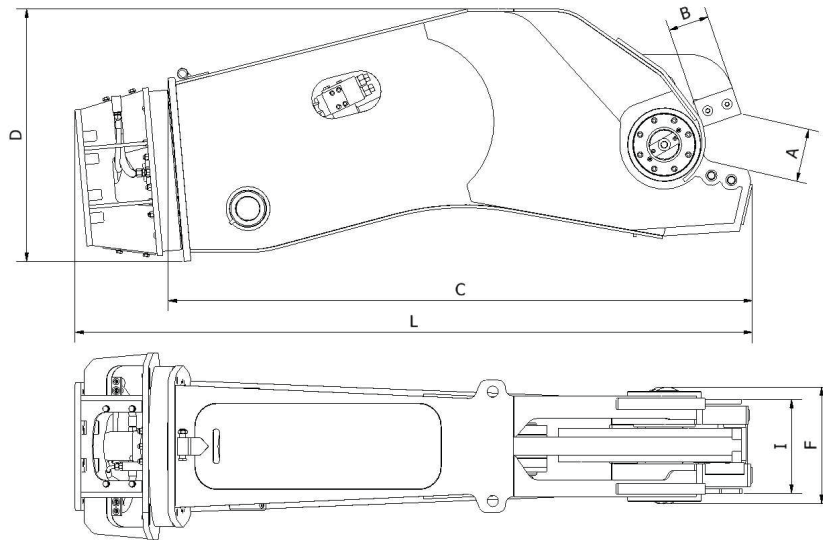

MODELLO MODEL MODÈLE MODELL	PESO WEIGHT POIDS GEWICHT	DIMENSIONI (mm) SIZES (mm) DIMENSIONS (mm) ABMESSUNGEN (mm)						
		A	B	C	D	L	I	F
MC 20 SB	2500	235	180	2575	1110	-	353	230
MC 20 SB R	2930	235	180	2575		2985	150	230

MODELLO MODEL MODÈLE MODELL	FORZA FORCE FORCE KRAFT	PRESSIONE PRESSURE PRESSION DRUCK	PORTATA OLIO REC OILFLOW DEBIT DURCHSATZ		TEMPI TIMES TEMPS ZEITE		PESO ESCAVATORE POSTO BRACCIO EXCAVATOR WEIGHT FIRST ARMPLACE POIDS PELLE PLACE BALANCIER	PESO ESCAVATORE POSTO BENNA EXCAVATOR WEIGHT BUCKET PLACE POIDS PELLE PLACE GODET
			MAX BAR	L/min	sec	t		
	t	MAX BAR	L/min		sec		t	t
		CLOSE	MIN	MAX	CLOSE	OPEN		
MC 20 SB	480/250	350	200	350	4.0	1.9	14 : 25	20 : 32

-Data and weight are indicative: the company reserve the right to make any improvements and changes required for good operation, without giving advance notice.



Unit 15 Vauxhall Industrial Estate
Greg Street, Reddish
Stockport
SK5 7BR
United Kingdom

Telephone: 0844 770 7969

Fax: 0844 770 7979

web: www.approvedhydraulics.co.uk