

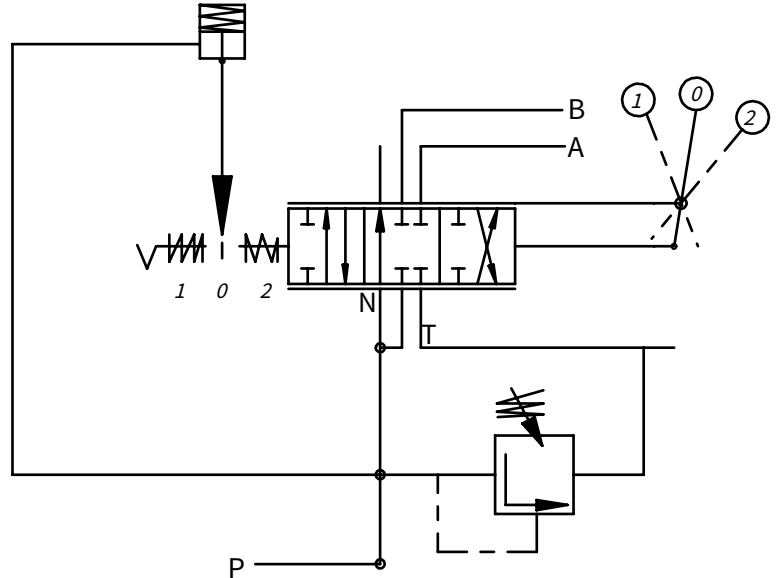

Log Splitter Valve 80LPM Auto Kick Out

The P81 is an on/off directional control monoblock valve and is designed as a log splitter valve. It directs the working fluid between hydraulic pumps and consumers (hydraulic cylinders, motors etc.) and the tank. It has a spring centered in one direction and a pressure release detent in the other direction. The P81 has an automatic kick back on completion of a cylinder stroke and has a built in adjustable inlet relief valve.



STANDARD FEATURES

- Hydraulically balanced, hard chrome plated spool
- Lever system in which the handle can be installed in an up or down position
- Detent release pressure adjustable from 70 to 140 bar
- Flow capacity of 80 l/min
- In neutral position both work ports are blocked and the pump unloads the tank

Nominal flow rating		80 l/min	21 gpm
Operating pressure (max.)	at port P	250 bar	3600 psi
	at work ports A and B	300 bar	4300 psi
Back pressure (max.)	outlet port T	10 bar	150 psi
Internal leakage (standard) A(B) > T	p - 120 bar	20cm ³ /min	1,2in ³ /min
Fluid		Mineral base oil	
Fluid temperature	with NRB (BUN-A) seals	from -20° C to 80° C	from -4° F to 176° F
	operating range	from 15 to 75 mm ² /s	from 15 to 75cSt
Viscosity	min.	12 mm ² /s	12cSt
	max.	400 mm ² /s	400cSt
Max contamination level		-/19/16 - ISO 4406	NAS1638 - class 10
Ambient temperature for working conditions		from -40° C to 60° C	from -40° F to 140° F
Spool stroke		7.9 mm	0,3 in
Actuating Force		<220 N	<50 lbs

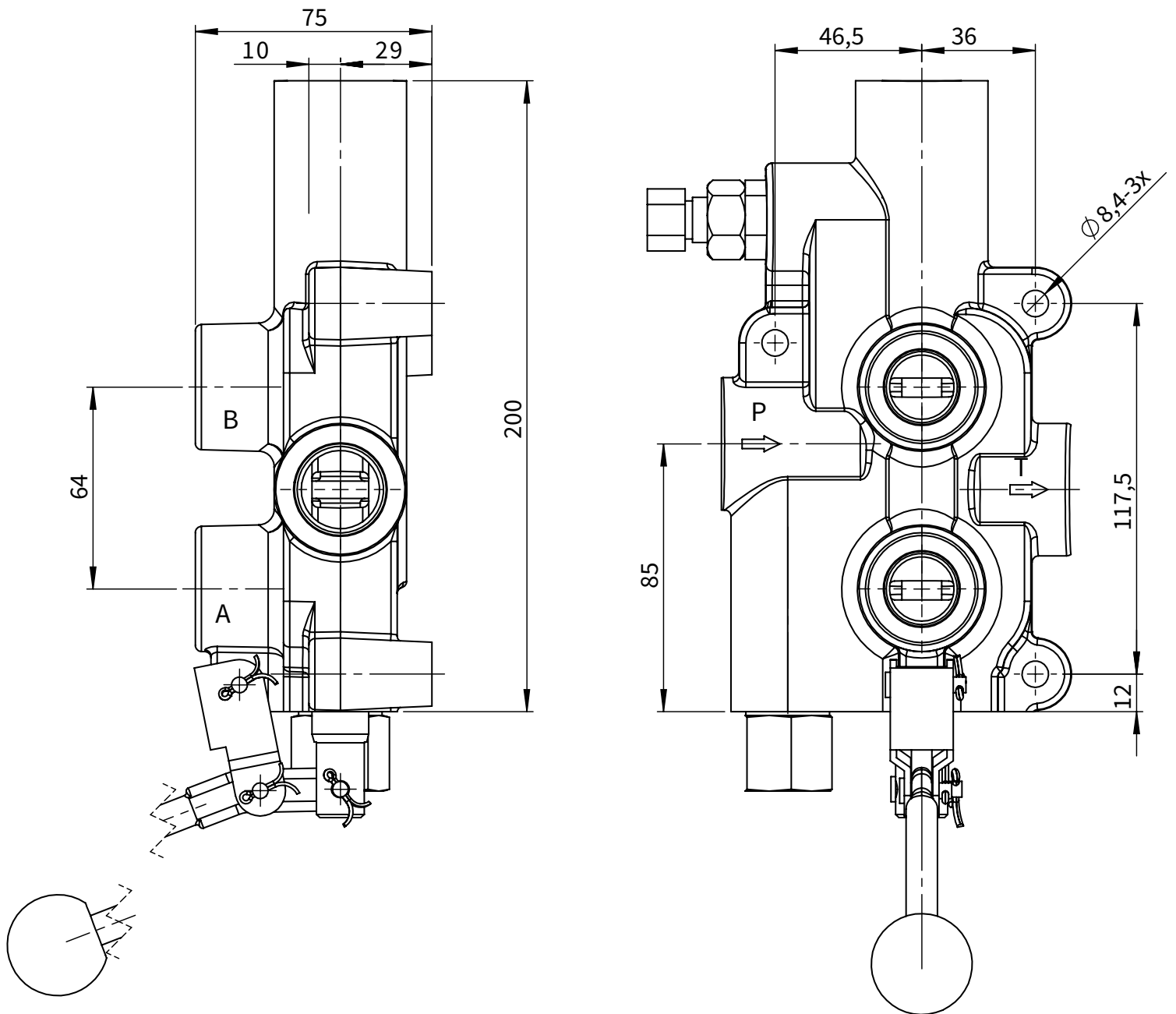

Available threads:

UN-UNF (order code S10)

Working ports A, B: 7/8-14UNF

Inlet port P: 1-1/16-12UNF

Outlet port T: 1-1/16-12UNF

NPTF (order code N)

Working ports A,B: 1/2-12 NPTF

Inlet port P: 3/4-14 NPTF

Outlet port T: 3/4-14 NPTF

BSP (order code G12)

Working ports A, B: G 1/2

Inlet port P: G 3/4

Outlet port T: G 3/4

Order Code: P81 A 2 G

Port type (S - UN-UNF, G - BSP, N-NPTF)

Spool detent - detent with hydraulic release (70 to 140 bar)

Spool type (A)

Directional control valve (80 l/min)

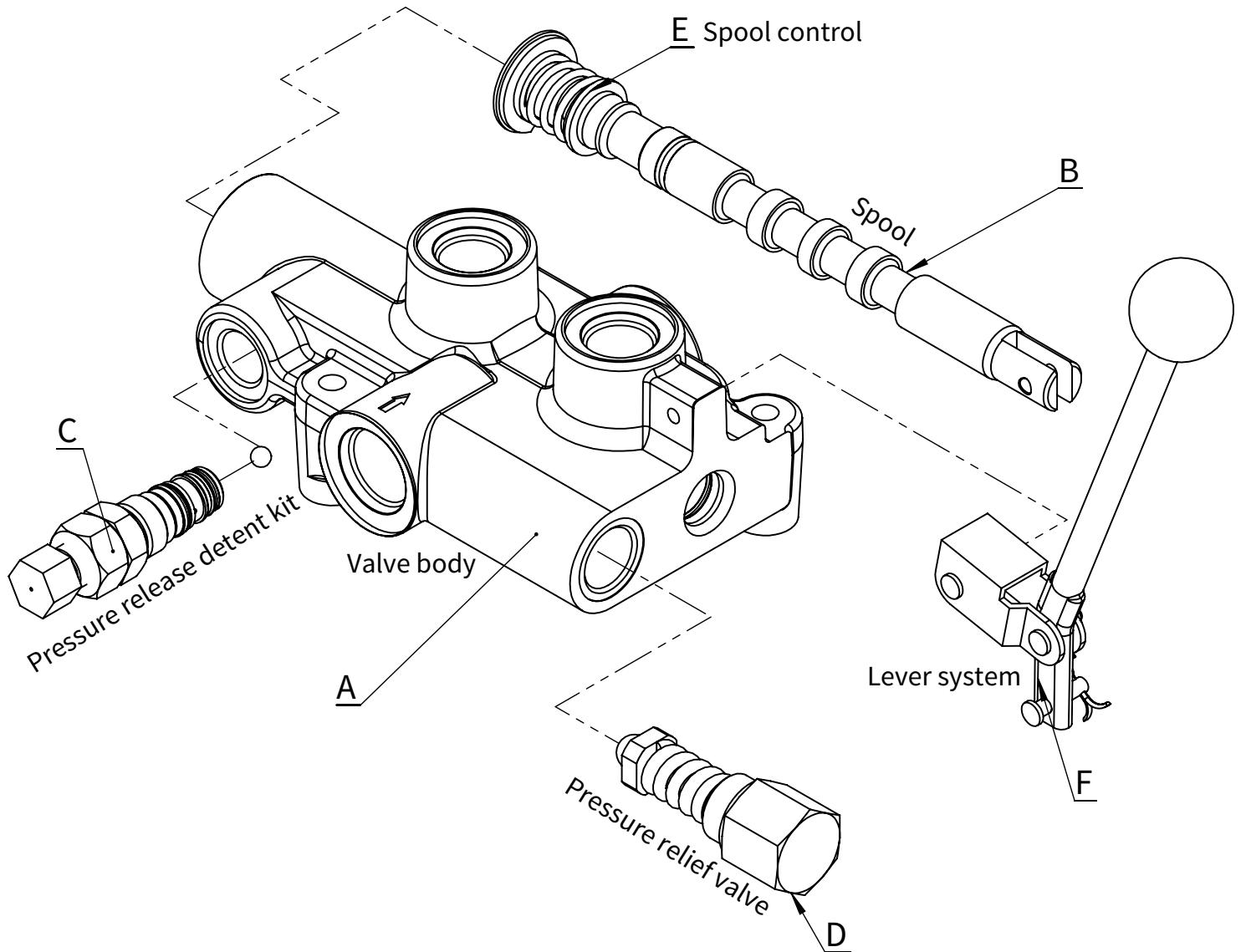

Code	Part No.	Description
A	414.00.00.04	Valve body
B	414.01.00.08	Spool
C	414.04.00.00	Pressure release detent kit
D		Pressure relief valve
E		Spool control
F		Lever system

Pressure Release Detent

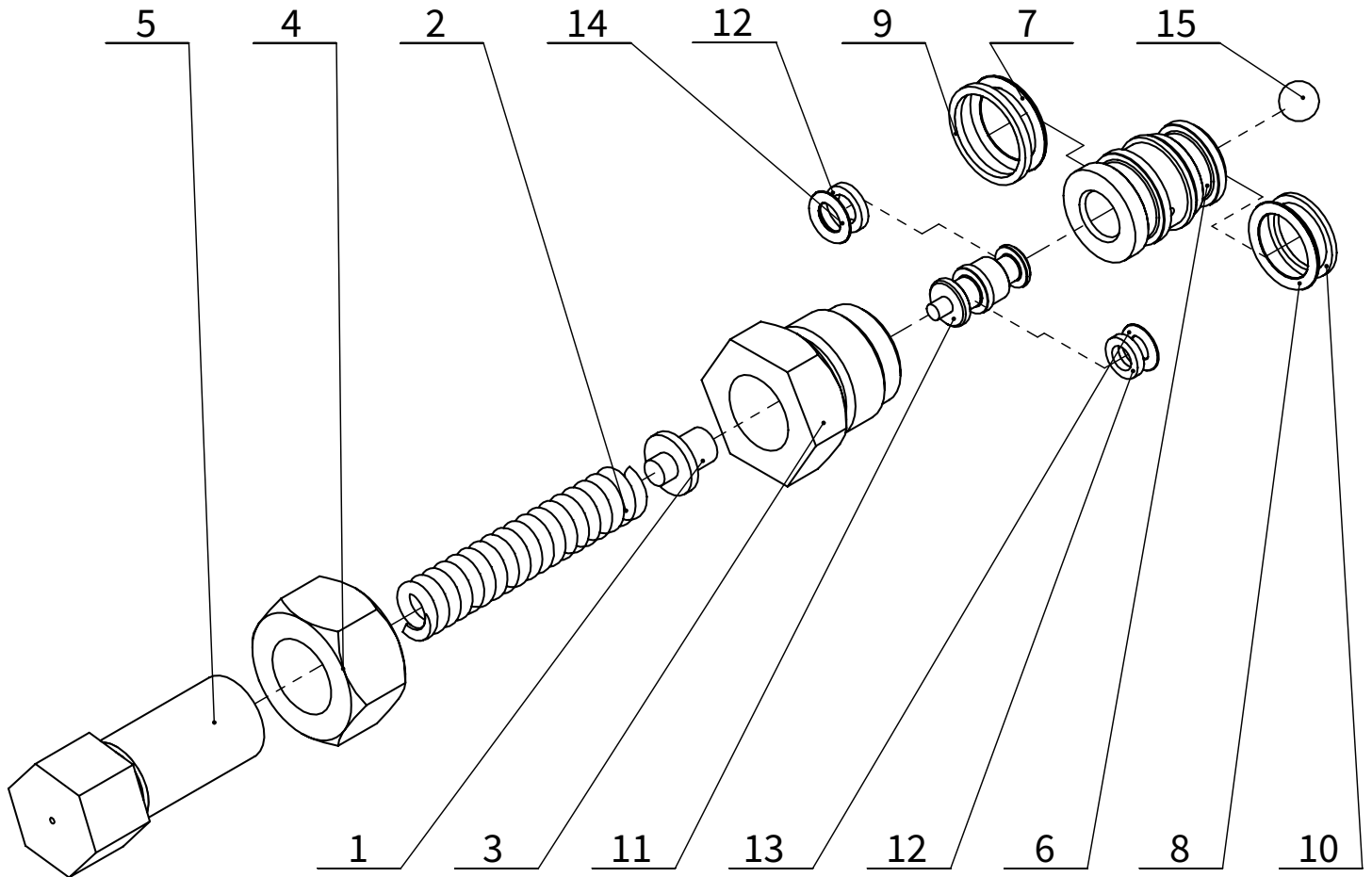

POS. #	PART #	DESCRIPTION	QTY.
1	414.02.00.01	SPRING ADAPTER	1
2	79.00.03	SPRING	1
3	414.02.00.03	PLUG	1
4	414.02.00.04	JAM NUT	1
5	414.02.00.05	ADJUSTING SCREW	1
6	414.03.01.01	PISTON SLEEVE	1
7	DIN 3771	O-RING 12.5x1.8	1
8	DIN 3771	O-RING 11.2x1.8	1
9	-	BACKUP RING 16x1,3x1,4	1
10	-	BACKUP RING 14.28x1x1.3	1
11	414.03.02.01	PISTON	1
12	-	BACK-UP WASHER 5.1x1.4	2
13	DIN 3771	O-RING 4x1.8	1
14	DIN 3771	O-RING 5x1.8	1
15	-	STEEL BALL	1

This feature provides a pressure release detent for the spool "out" (handle in) position. When the spool is manually placed in the detent position oil is directed to the "B" work port (the port away from the handle). When the pressure in the "B" port reaches a preset level the detent will release and the spool will center. The factory setting is 70 bar. The detent release pressure is adjustable by loosening the jam nut (15). Turning the adjusting screw (16) clockwise will increase the detent release pressure and counterclockwise will decrease the pressure.

NOTE: If the detent release pressure is adjusted too high the spool will not center, if the pressure is too low the detent will not hold.

Relief Valve

POS. #	PART #	DESCRIPTION	QTY.
1	-	STEEL BALL	1
2	414.00.00.18	ADAPTER	1
3	79.00.03	SPRING	1
4	414.00.00.15	ADJUSTING SCREW	1
5	DIN7603	WASHER 21x1.5	1
6	414.00.00.14	ACORN NUT	1

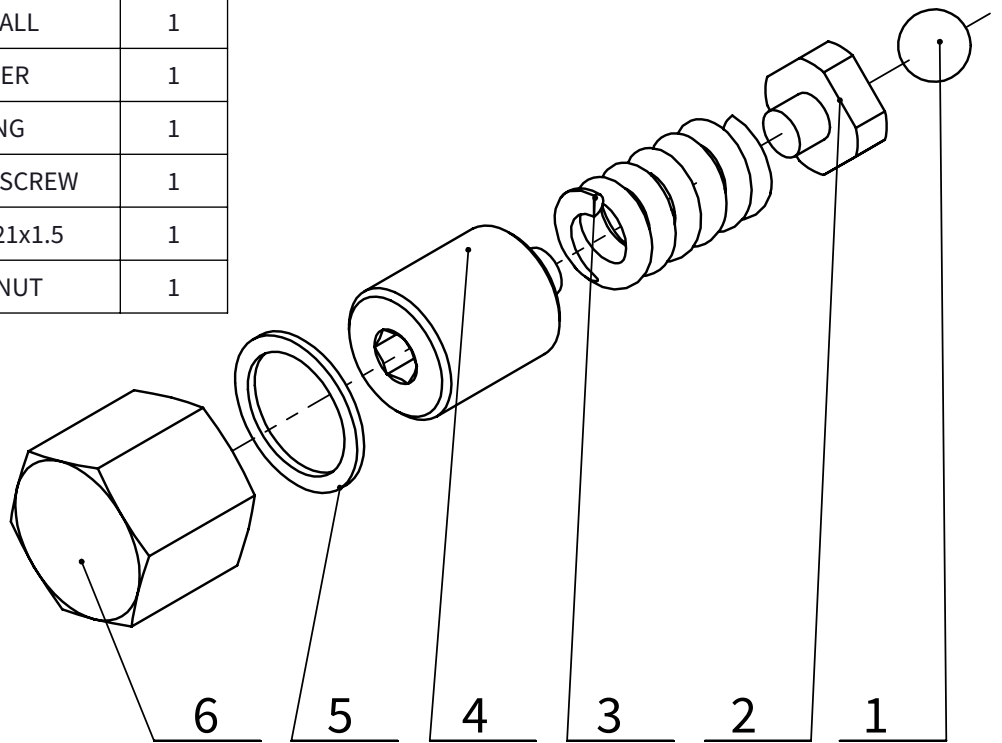

An adjustable ball spring relief valve

The standard factory setting is 150 bar. Other settings can be specified. The relief valve is adjusted by removing the acorn nut (6) and turning the adjusting screw (4). Turning the adjusting screw clockwise will increase the pressure and counterclockwise will decrease the pressure.

Lever system

The lever system can be turned "up" or "down" depending on the location of the valve on the machine. It is done by simply rotating the lever on 180 degrees with respect to its own axis. All pins are locked to position by the use of cotter pins DIN94 (not shown)

POS. #	PART #	DESCRIPTION	QTY.
1	414.00.00.09	LINK	1
2	414.00.00.11	LEVER	1
3	414.00.00.07	CLEVIS PIN	3
4	-	KNOB	1
5	-	COTTER PIN	3

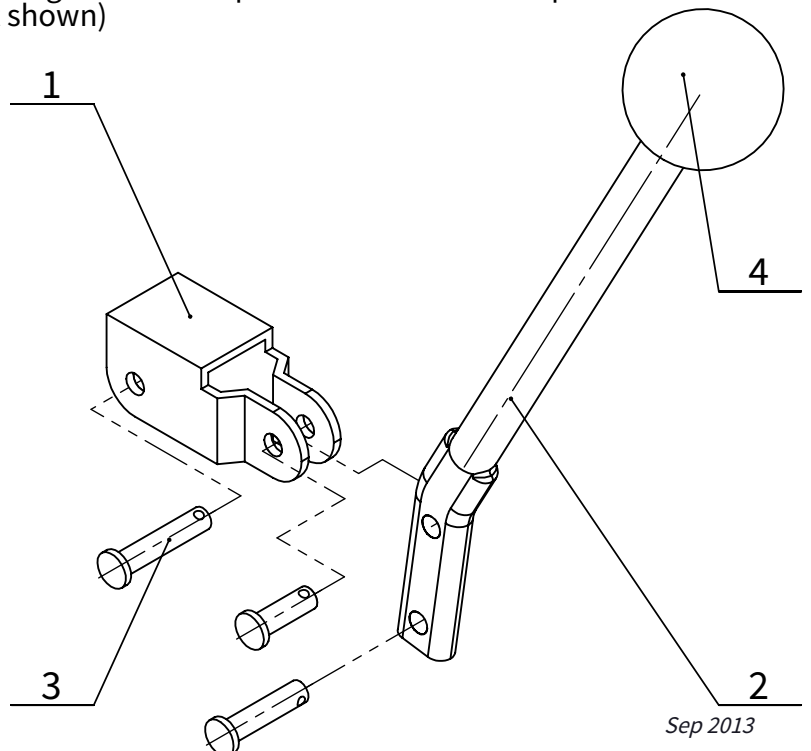

Spool and spool control

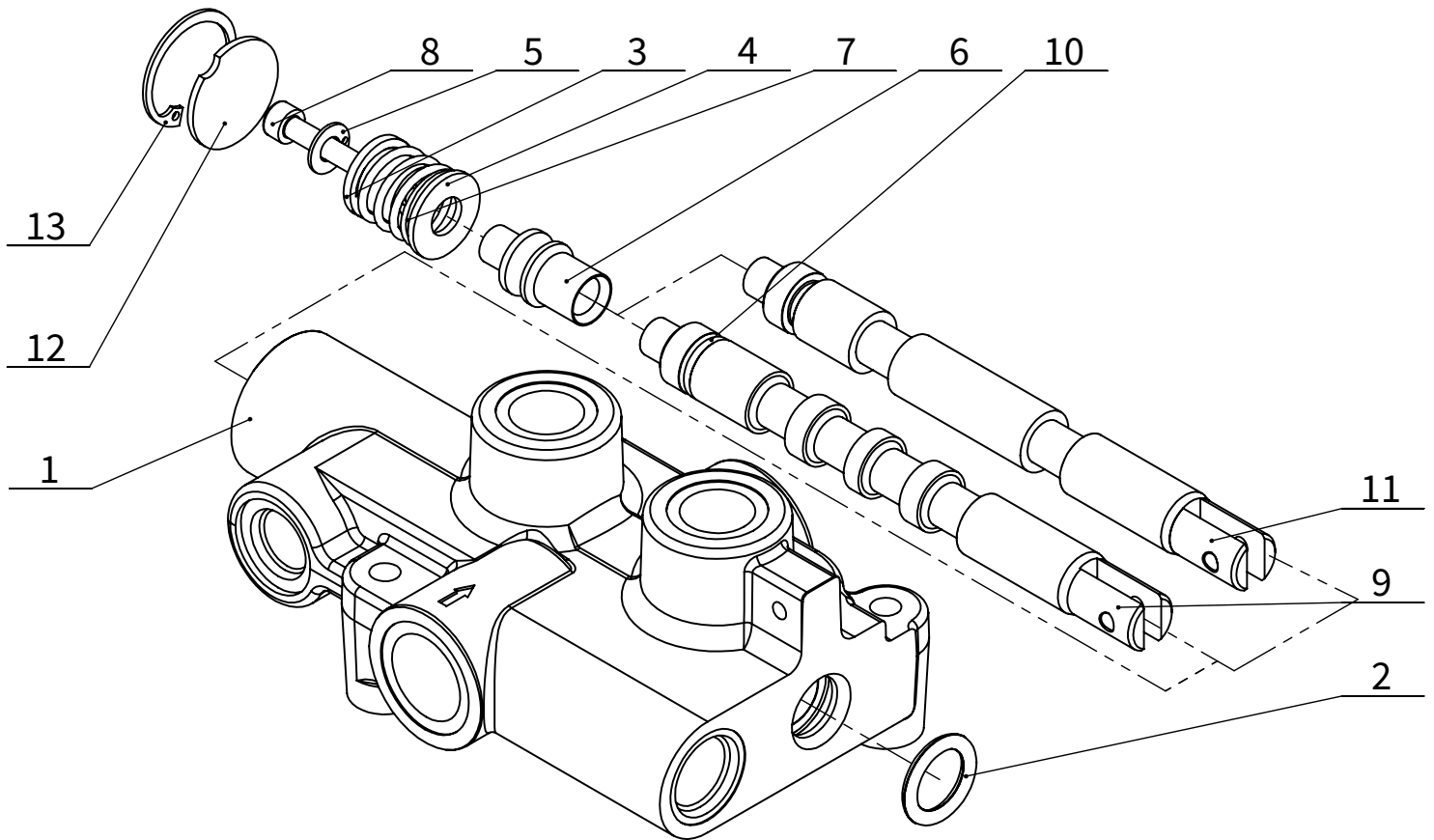

POS. #	PART #	DESCRIPTION	QTY.
1	414.00.00.04	VALVE BODY	1
2	DIN 3771	O-RING 18x4	1
3	414.01.00.01	STOP CUP	1
4	414.01.00.05	WASHER	1
5	12010.01.05	WASHER	1
6	414.01.00.06	DETENT SLEEVE	1
7	79.00.03	SPRING	1
8	-	HEX SOCKET HEAD CAP SCREW M6x40	1
9	414.01.00.08	VALVE SPOOL	1
10	DIN 3771	O-RING 12x3	1
11	414.01.00.10	SPOOL M	1
12	414.00.00.02	WASHER	1
13	DIN	CIRCLIP RING	1

Code	Part No.	Hydraulic scheme
A	414.01.00.08	
M	414.01.00.10	

How to replace a broken o-ring (2), (10)

To replace the o-ring (10) on the spool (9) or (11) the following procedure must be followed.

1. Remove the pressure release detent (it is not shown here, refer to page 4/7)
2. Use a needle nose pliers to reach into the cavity and to grip onto the small stem on the piston. Remove the piston.
3. Remove the steel ball at the bottom of the piston cavity (a magnet may help).
4. After removing the snap ring (13) and end plate (12) at the rear, remove the spool assembly by pushing the spool out the rear. Now you can change o-ring (2)
5. Secure the spool (9) or (11) and remove the head cap screw (8). The spool may be secured by using a vice to clamp over the handle end clevis slot (with the slot perpendicular to the jaws) or by placing the clevis slot over a rigid bar. Do not clamp on the outside surface

of the spool. Remove the cap screw from the spring end of the spool. If the cap screw socket is rounded out, it can be removed by using a drill to remove the button head, then removing the attachment parts and then using a locking pliers to grasp and remove the screw shank. Finally remove parts (3), (4), (7) from the spool (9) or (11).

6. The existing o-ring (10) can be cut off. The new o-ring is installed from the attachment end. After placing the new o-ring wait a few minutes so it can regain its original shape, and then reinstall the spool.

7. The valve is reassembled by following the same directions in reverse. The o-ring and spool must be lubricated with oil before installation.