



Side Mounted Aluminium Oil Tank With Filter

Our hydraulic tanks are manufactured from high quality aluminium plate of 2.5mm thickness. Welding of the seams and main joints are carried out by robotic equipment to ensure the highest quality and reliability. All tanks are pneumatically tested prior to shipping. This range of hydraulic tanks are all fitted with a return filter to aid the systems cleanliness.



HYDRA PART	MATERIAL (ALUMINIUM)	SIDE MOUNTED	RETURN FILTER FITTED	CAPACITY (LITRES)
X	X	X	X	X

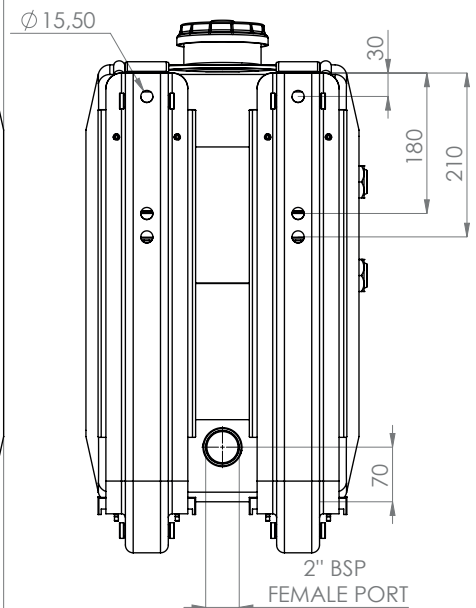
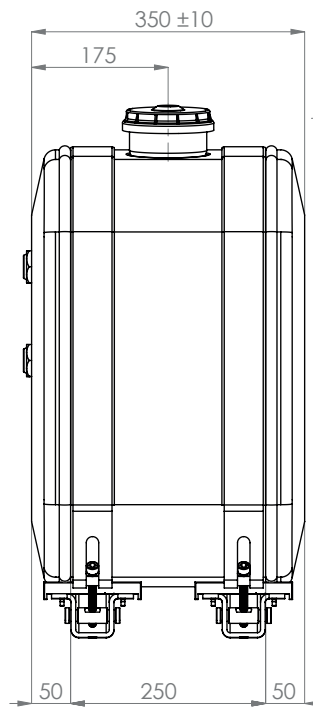
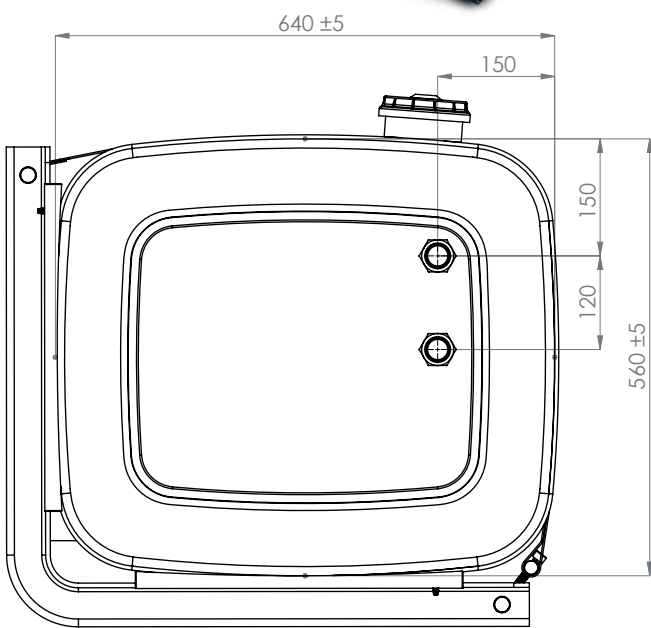

100 Litre

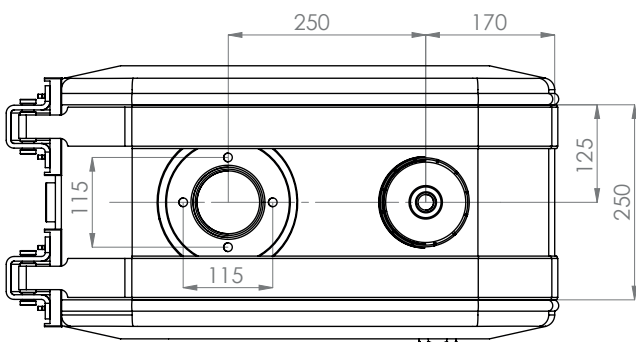

ITEM	QTY	DIMENSIONS	MATERIAL
1	1	TANK BODY	ALUMINUM 2.5 mm
2	2	SIDE PLATE	ALUMINUM 2,5 mm
3	2	BRACKET	DC01 QUALITY ST-37 5mm
4	2	BRACKET RUBBER	RUBBER
5	2	BELT	6112 QUALITY STEEL 2mm
6	2	BELT RUBBER	RUBBER
7	1	FILLING NECK	PLASTIC
8	1	FILTER SYSTEM	
9	2	SPY EYE	PLASTIC 1" BSP
10	1	SUCTION ADAPTER	ALM 2 "BSP FEMALE PORT
11	2	PIN ASSEMBLY	11SMNPB30 QUALITY AUTOMAT Ø20 STEEL