

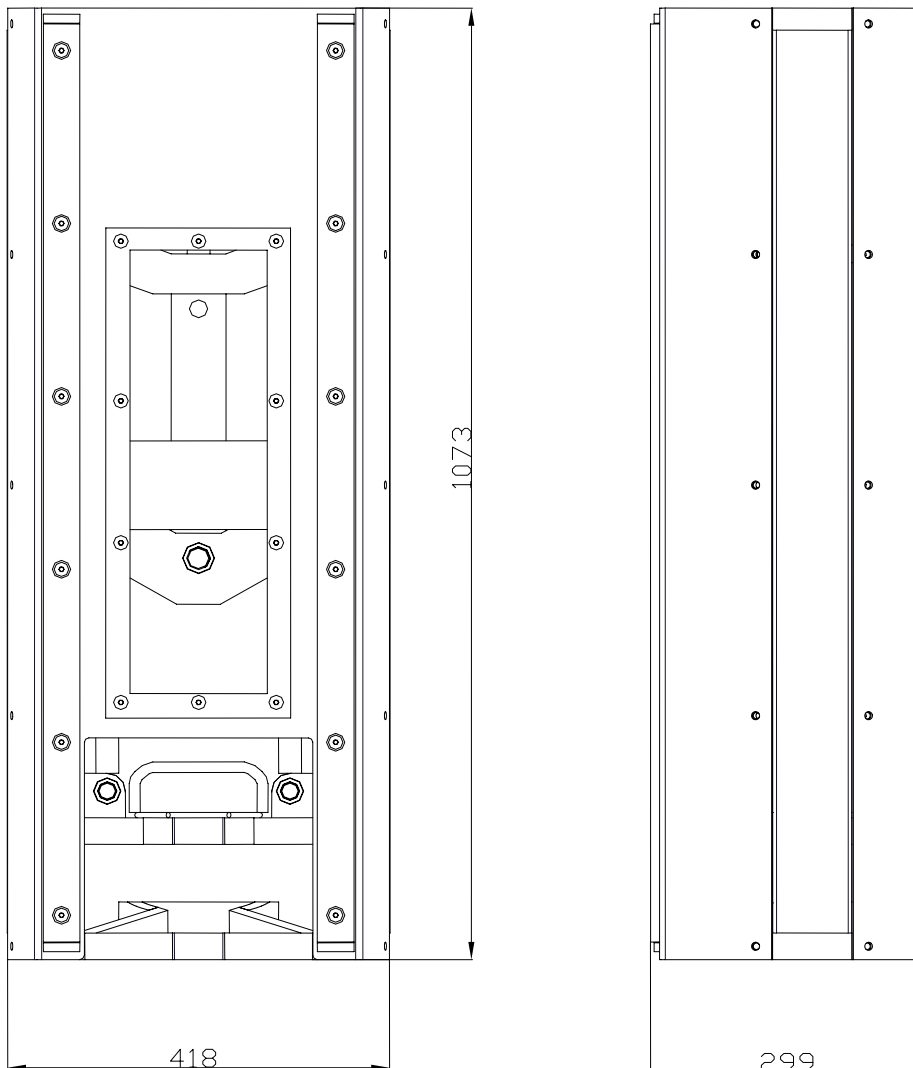

GEJO 01
CONTAINER DISCHARGE UNIT
'Mushroom' system

TECHNICAL DATA:

Type	:	GEJO 01
Maximum load	:	2500 kg
Height	:	1380 mm (including rotator)
Width	:	422 mm
Weight	:	200 Kg
Working pressure	:	180 bars





Hydraulic diagram GEJO 01

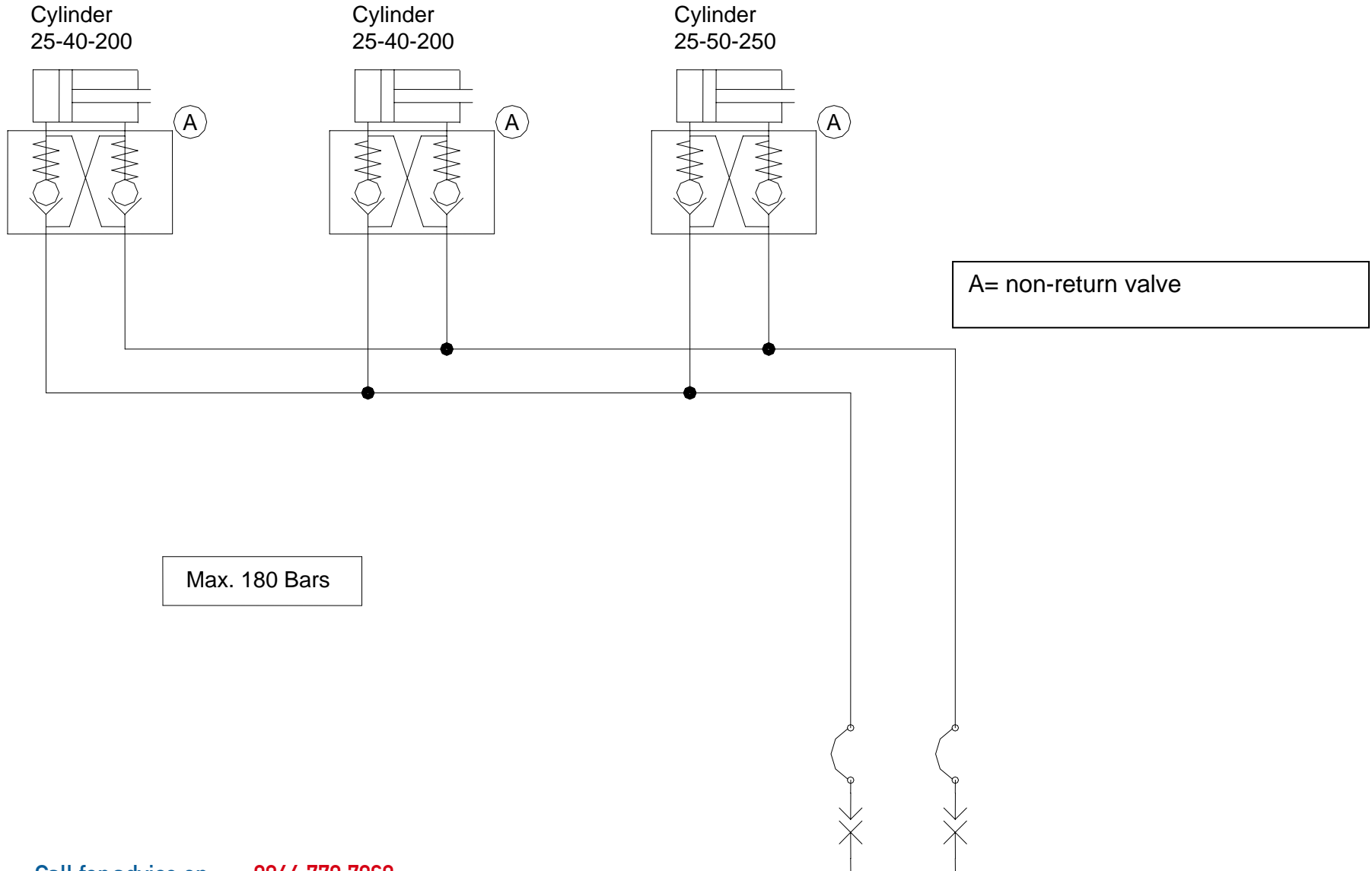

A= non-return valve

Max. 180 Bars



GEJO 01

PARTS LIST

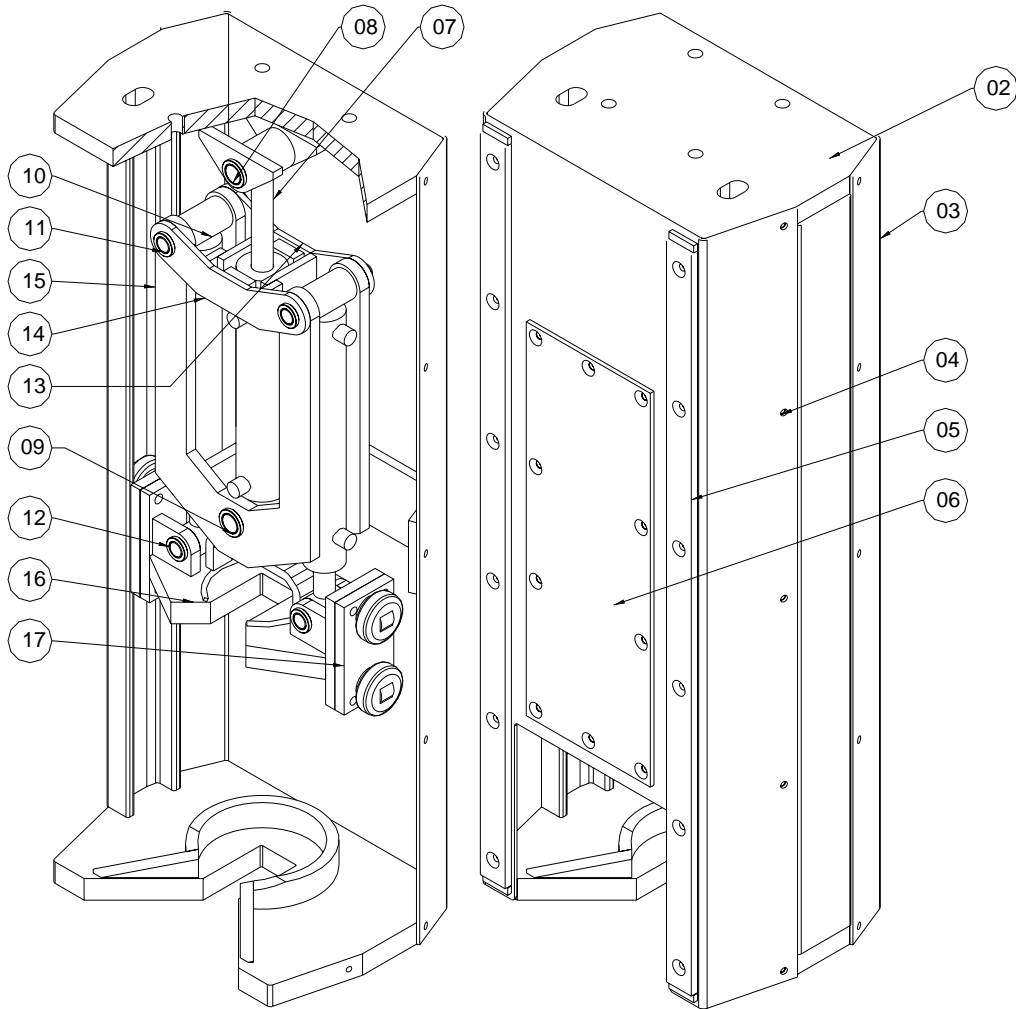

Pos. No.	Article numbe	Description	Quantity
02	31000002	Frame complete	1
03	31000003	Rear cover plate	1
04	31000004	Front cover plate	1
05	31000005	Rubbing strip	4
06	31000006	Viewing window	1
07	31000007	Cylinder	1
	31000019	Seal kit for cylinder 31000007	1
08	31000008	Cylinder rod pin	2
09	31000009	Cylinder housing pin	2
10	31000010	Cylinder	2
	31000020	Seal kit for cylinder 31000010	2
11	31000011	Cylinder rod pin	1
12	31000012	Cylinder housing pin	1
13	31000013	Inner attachment plate	1
14	31000014	Outer attachment plate	1
15	31000015	U-plate	2
16	31000016	Guide frame	1
17	31000017	Roller plate	2
	31000018	Carrier bracket	1