

DOC 600

For tractors 150- 200 hp

REAR HEDGE MOWERS

DOC 600

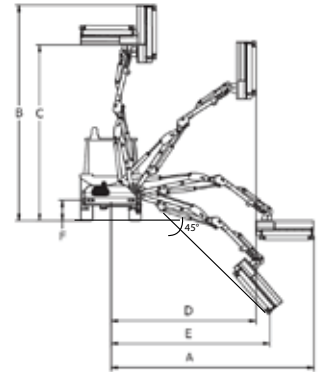

DOC 600	9.0
A (mm)	9.000
B (mm)	9.100
C (mm)	8.000
D (mm)	7.900
E (mm)	7.100
F (mm)	550



Hydraulic hedge mower of 8.9 m. range, for tractors HP 150/200 and weight 7000 kg, suitable for heavy drainage and road mowing, strong, compact, connected on the tractor in high position and fast on the motions.

ARM MOWER

TRACTOR

Model	Extension E (mm)	Telescopic	Weight (kg)	Oil tank (L)	Head (model)	Pump (l/min)	Hydraulic Motor (HP [kW])	Power (HP [kW])	Weight (kg)	Width (m)	PTO (rpm)
DOC 600	9.000	2	1.810	260	30.5	120+20	67 (50)	150 / 200 (112 / 149)	7.000	2,5	540



P: Mechanism that allows to work flush to the wheel with long extension machines, with a very-good speed and handling quickness.

TECHNICAL FEATURES AND STANDARD EQUIPMENT

- Frame in structural steel ST 52
- Highly resistant steel DOMEX700 for 1st, 2nd arm and double telescopic extension terminal with hexagonal section
- Telescopic extension terminal on guide slides on ERTALON anti-wear material
- 90° rotating column and shock resistant hydraulic safety device
- Three points attachment 2nd and 3th category
- Oil tank 260 l
- Double gear pump group 3+2 - 120+25 l/min
- Bidirectional hydraulic motor HP 67 power
- Distributor with remote controls with mm 3000 flexible cables
- Self-levelling floating system
- Feeler roller recordable on 3 positions
- Head rotating angle 200°
- Helicoidal rotor with jointed cut blade KC4
- Number revs to rotor 3000 rpm
- Fixing tie-rods
- Cardan joint
- Air-oil heat exchanger with radiating mass at high thermal exchange
- Rear underrun protection with lights
- Flail head mm 1300 MODEL 30.5 TTD 130 with direct transmission



KC4

Ø max 2 cm

standard equipment

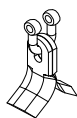

KC5

Ø max 2 cm

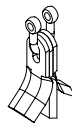

HC2

Ø max 4 cm

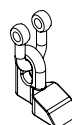

HF4

Ø max 6 cm



KF4

Ø max 4 cm



KF5

Ø max 4 cm

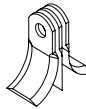

KF6

Ø max 3 cm



HF5

Ø max 6 cm

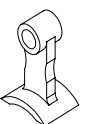

ACCESSORIES ON REQUEST

- Nitrogen accumulator for 1st arm suspension
- Rear flail head hitch
- Ventilator (tractor quick couplings)
- Trestle bracing
- Belt transmission "TTC"
- Closed circuit pistons Motor and Pump 70 hp *
- Hydraulic flail head hood
- Gear pump and motor Parker - 80 hp *
- Power-assisted with joystick
- 40 TTC 16 FA (1600 mm) TTC and FA included
- Biaxial prop. distributor with joystick SAUER DANFOSS
- Additional auxiliary line 3/8"
- Tie rods adapter Cat. 2 o 3

* with TTC

TERMINAL TOOLS - IN REPLACEMENT OF THE STANDARD MULCHER

BRANCH CUTTING BAR
BTZ5 15
BTZ5 18
BTZ10 16
BTZ10 19
BTZ10 22

DISC BRANCH CUTTER
DFG12
DFG15
DFG18

FOREST DISCS CUTTING BAR
BD3
BD4
BD6

DITCH CLEANER
PF80



pag. 27



pag. 28



pag. 29



pag. 30