

Dimensions

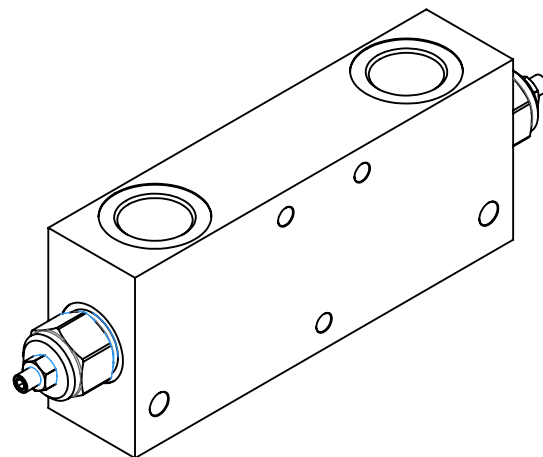

Hydraulic Symbol

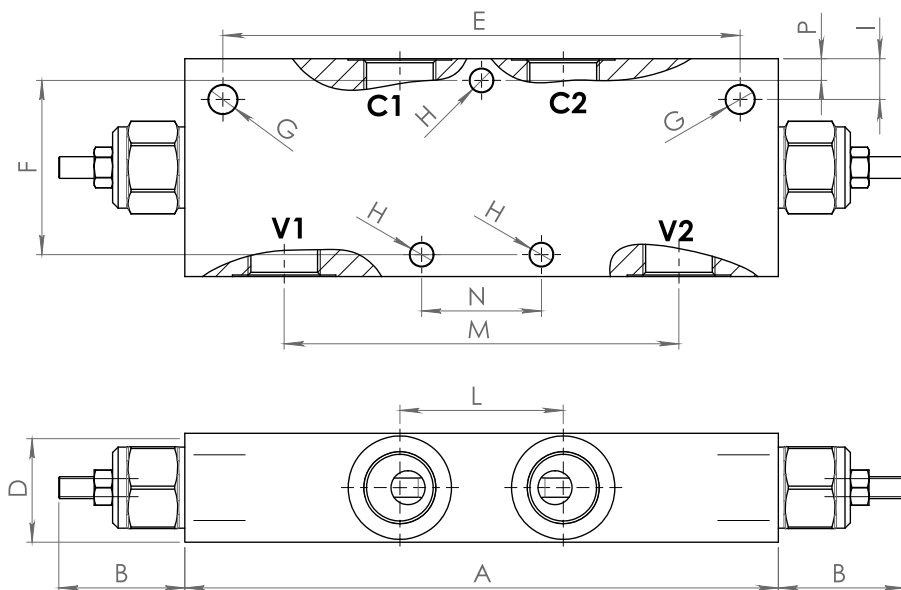
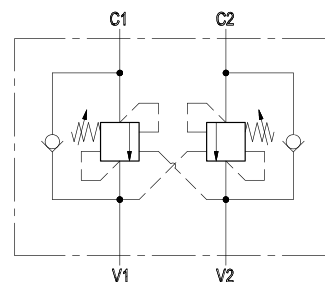

Size	A	B max	C	C1-C2 V1-V2 BSP	D	E	F	G	H	I	L	M	N	P	Weight kg
04	218	43,5	80	3/4	40	190	64	10,5	8,5	15	60	145	44	8	2,22
05	218	43,5	90	1	50	190	64	10,5	8,5	20	60	145	44	13	2,27

Curves

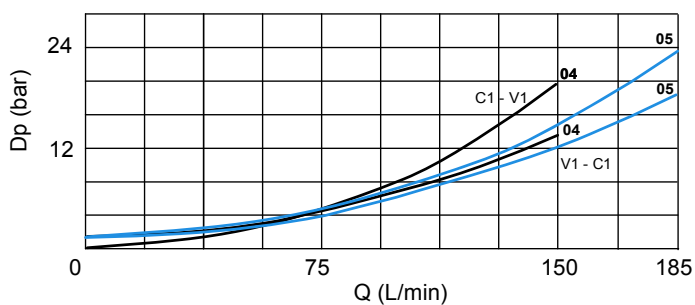

Features

Rated Flow	(04) 150 lpm - (05) 180 lpm
Max Pressure	350 bar
Pilot Ratio	6:1

Materials: Zinc plated steel cartridge, hardened steel inner parts.
Aluminium manifold.

Ordering Code

CBDLA -- --

Port Size BSP		Spring			
04	3/4	Pressure Range (bar)	Increase (bar/turn)	Standard Setting (bar) Q=5 lpm	
05	1	20	50 - 210	35	150
		30	100 - 350	60	200