

HP-AT-SM-150L

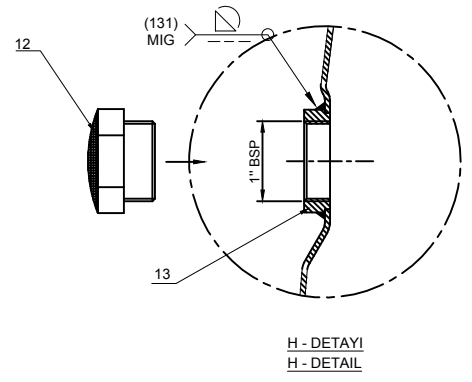

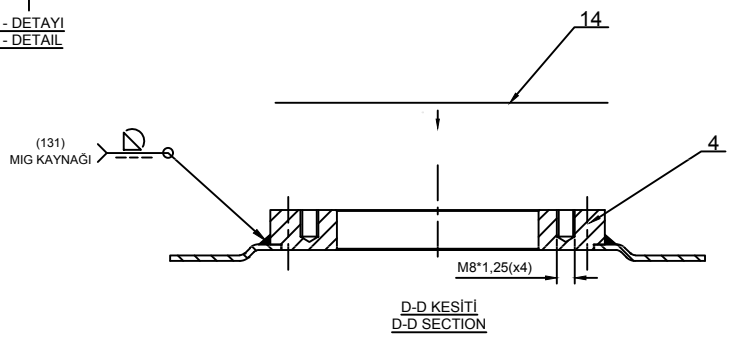

HP-AT-SM-150L

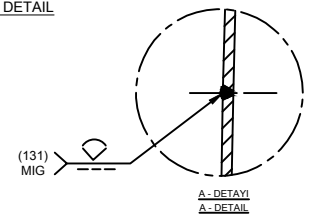
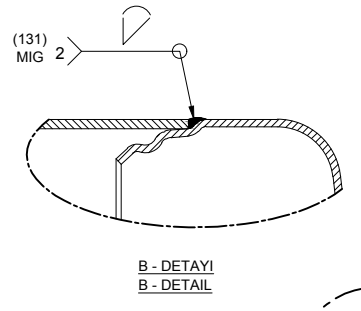
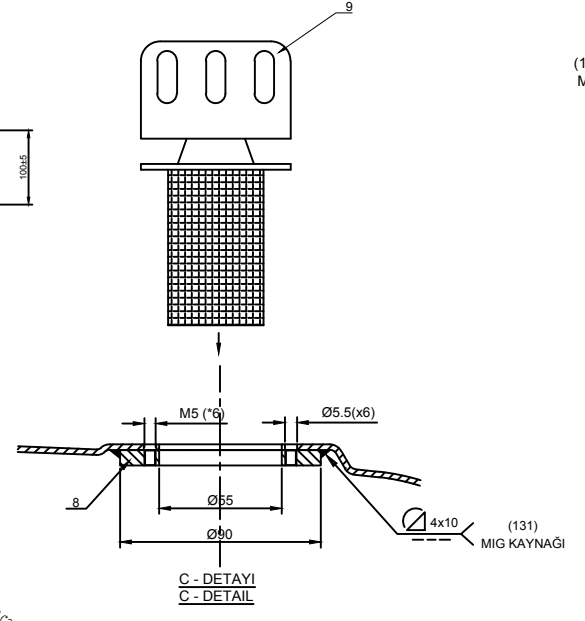
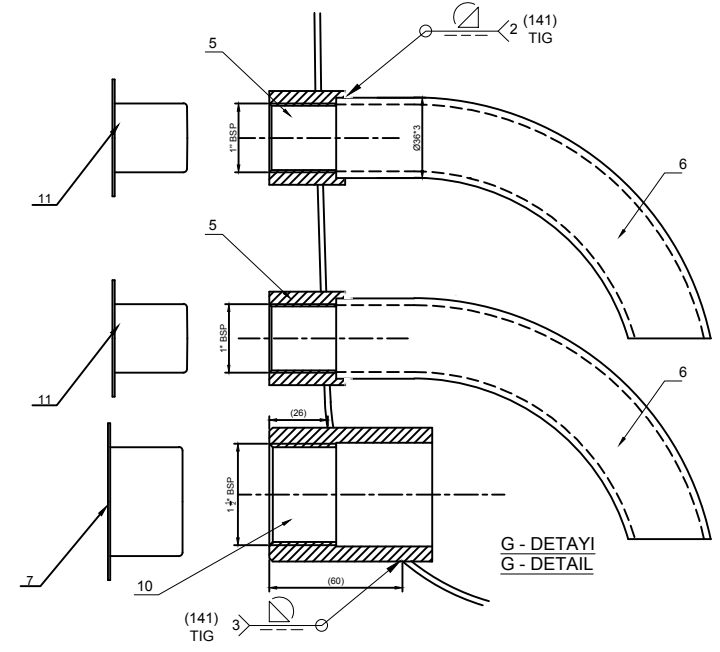
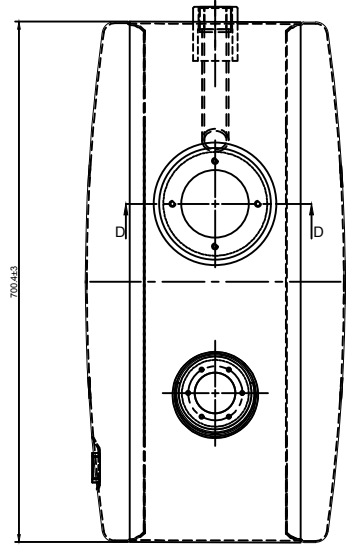
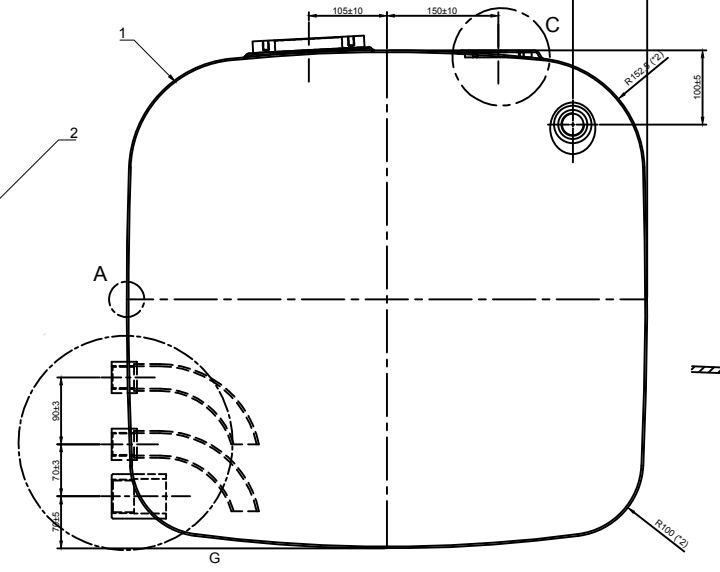
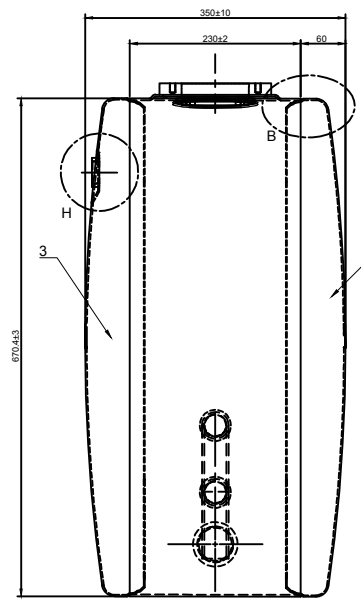
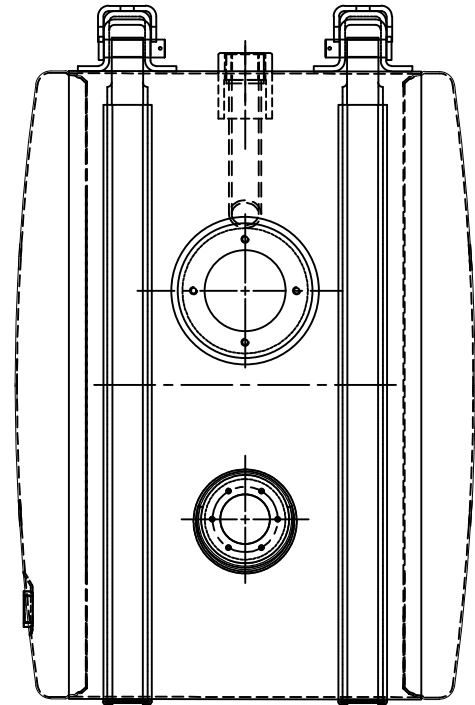
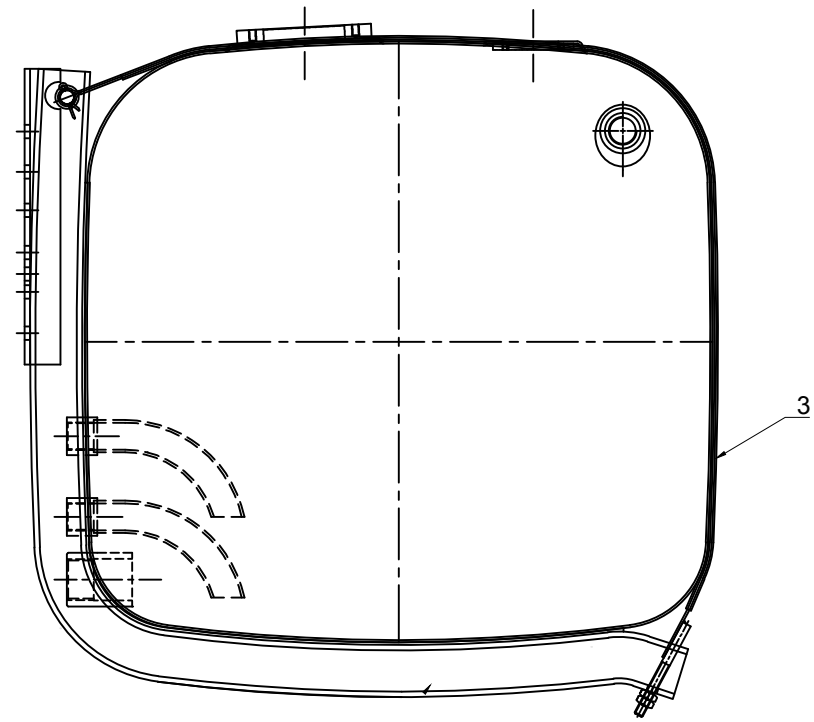
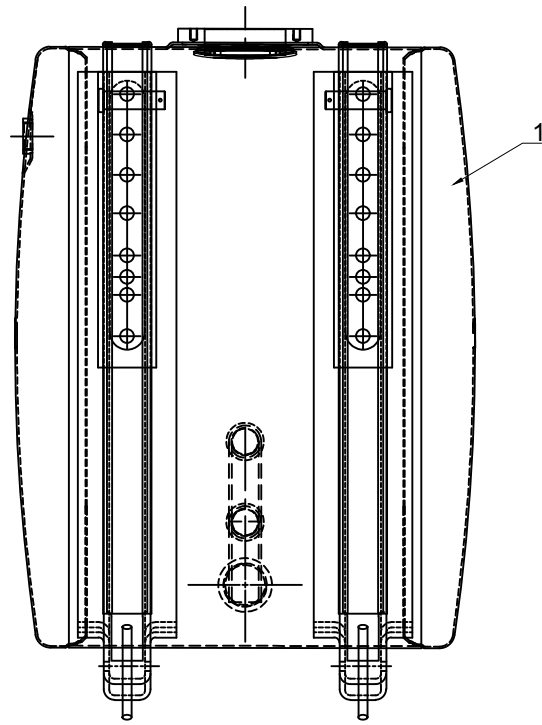

HP-AT-SM-180L



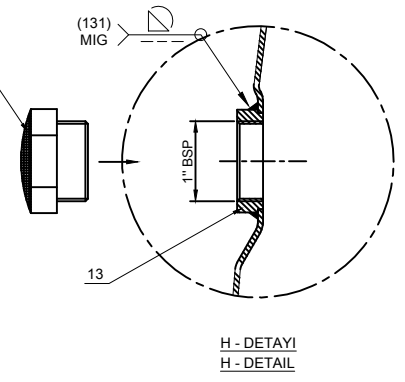
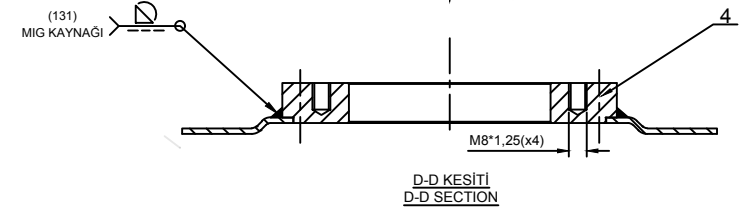
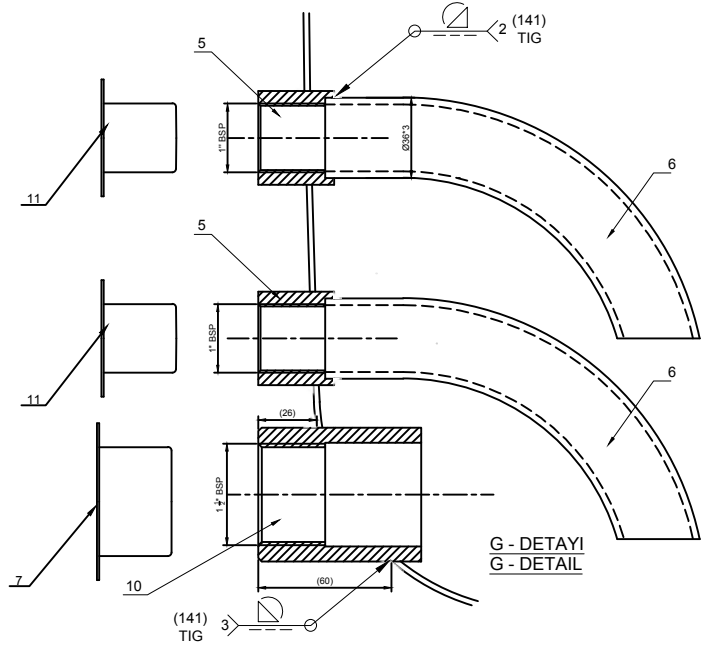
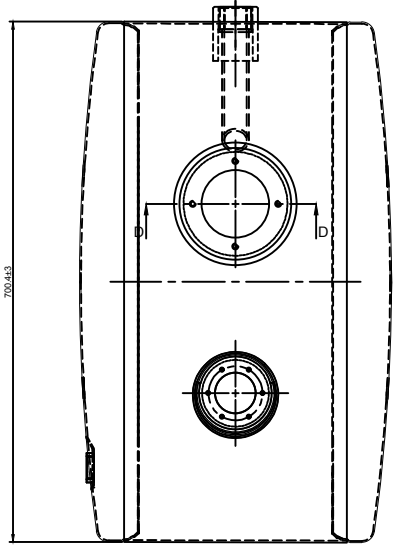
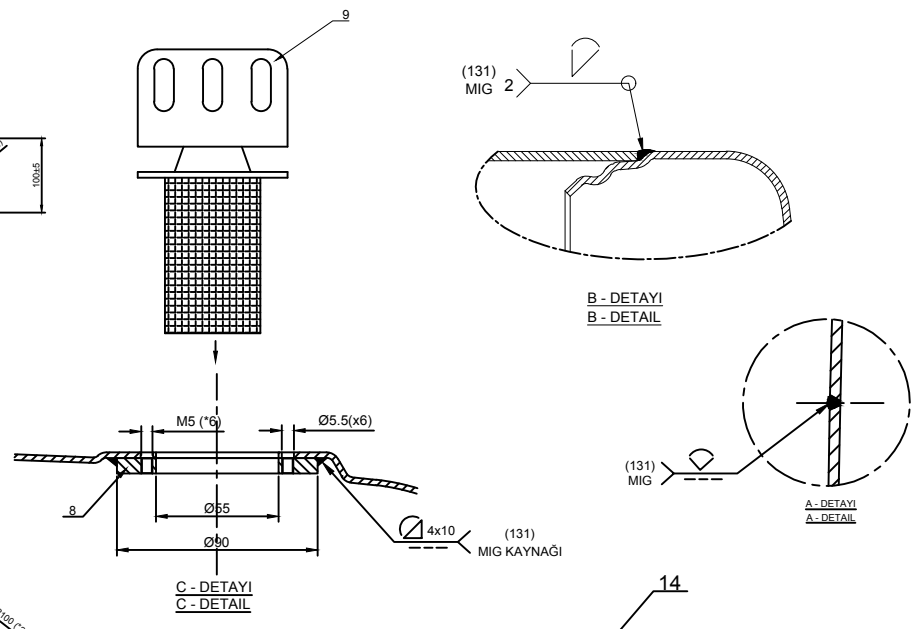
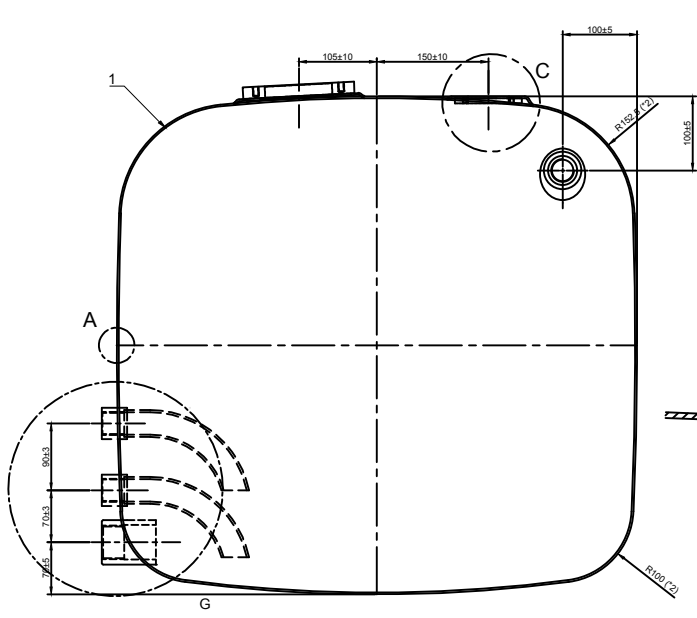
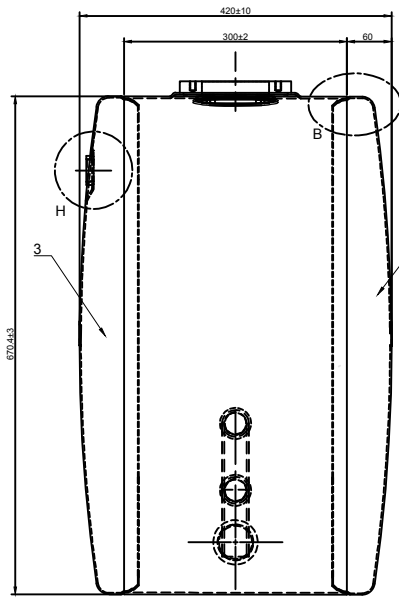

HP-AT-SM-180L

HYDRA
PART

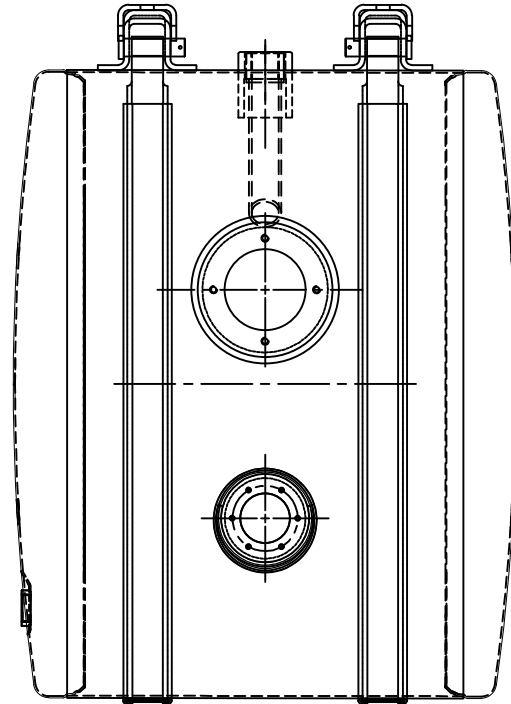
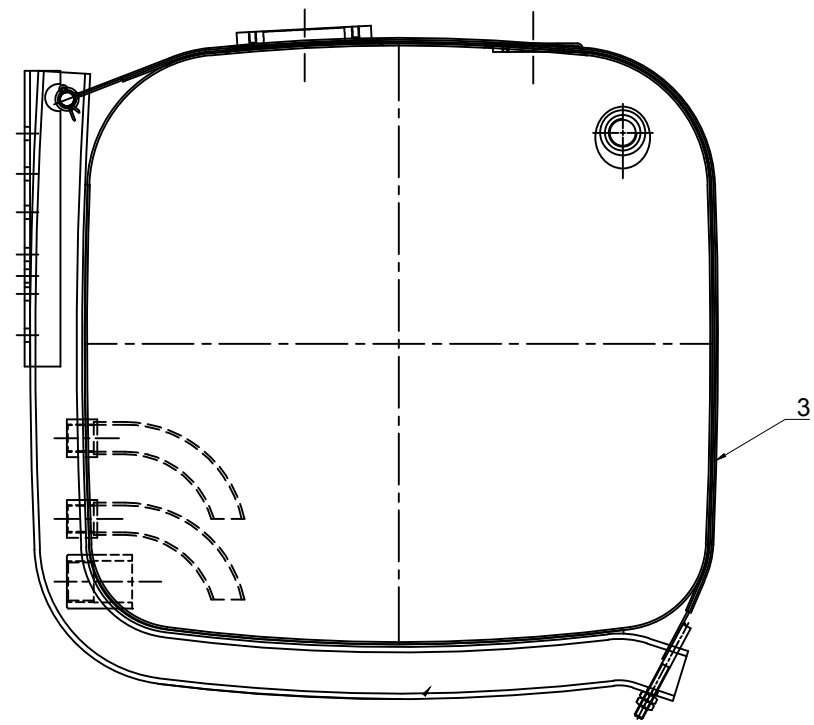
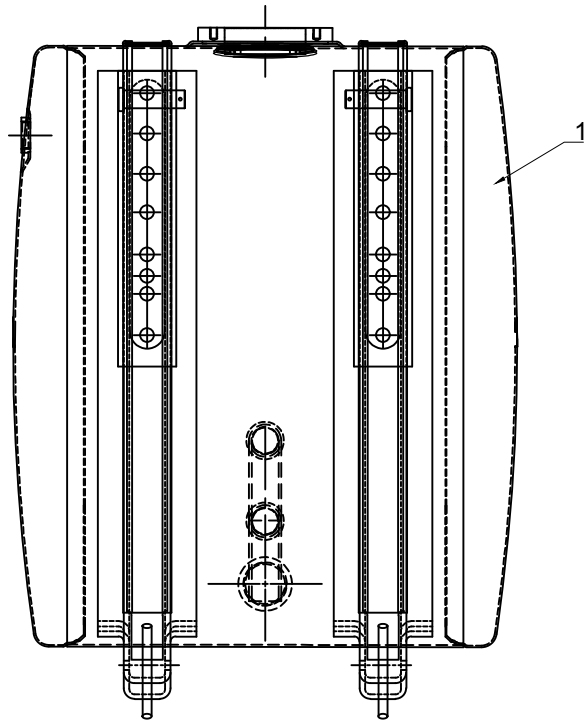

HP-AT-SM-200L



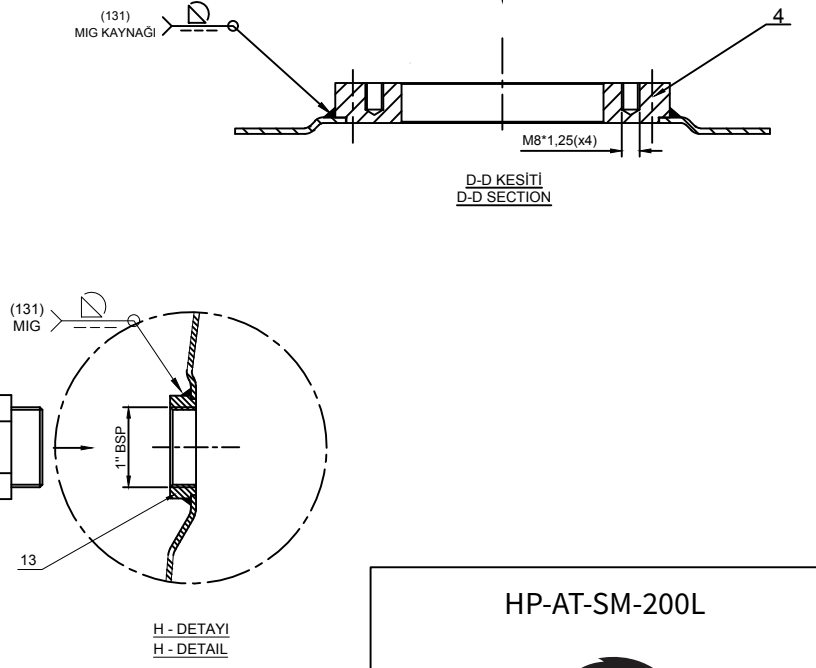
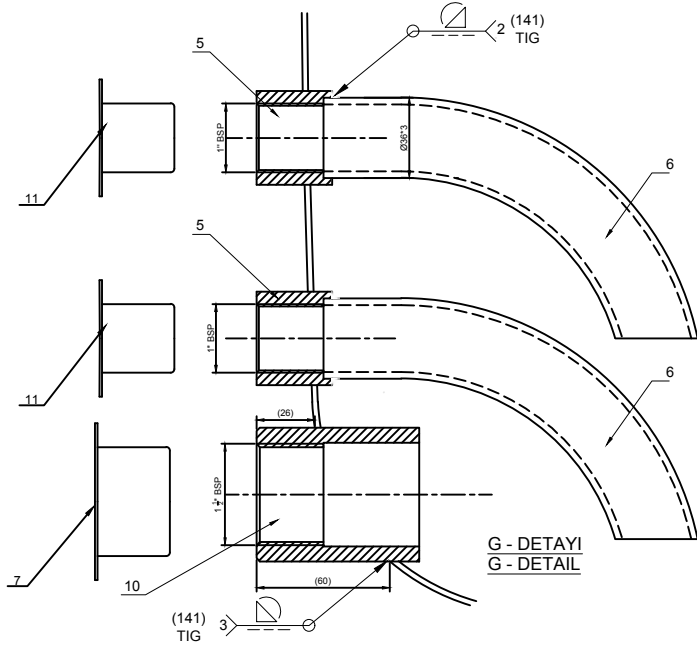
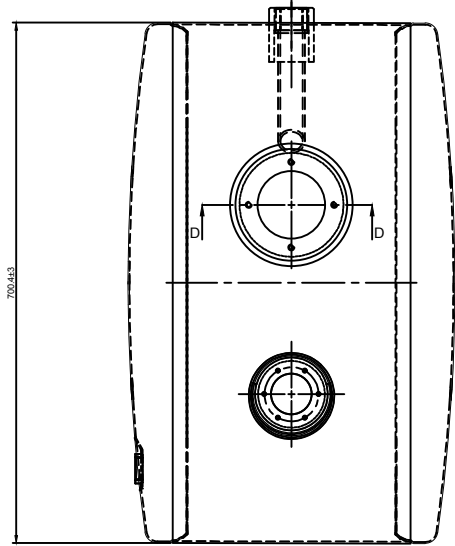
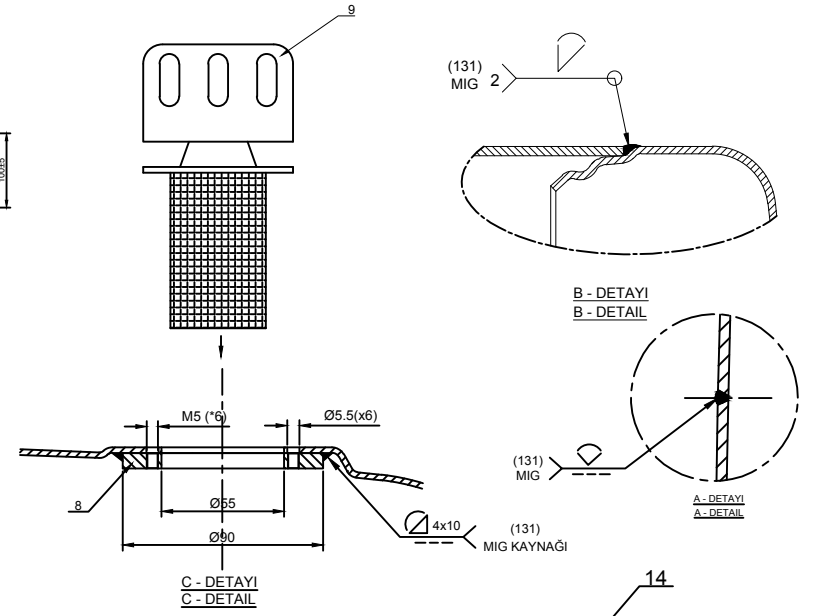
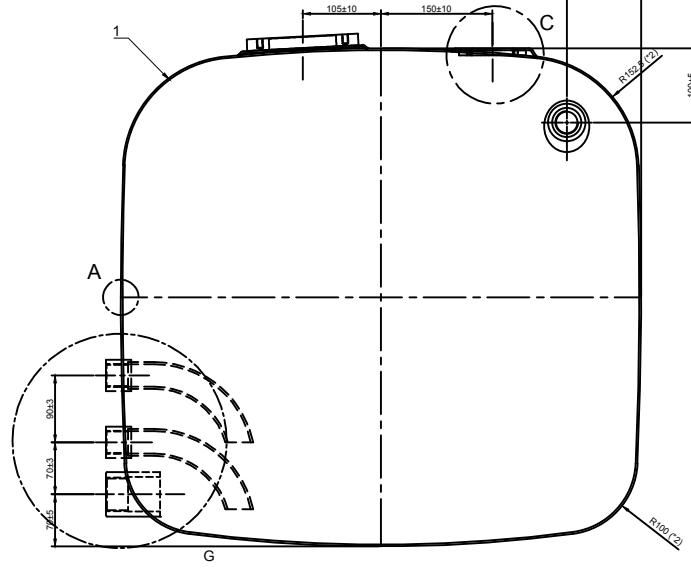
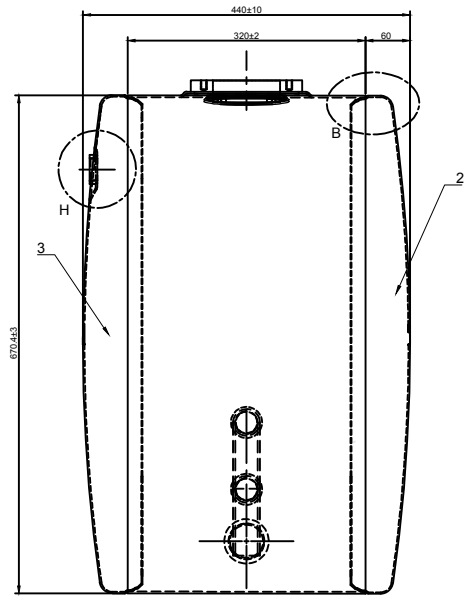

HP-AT-SM-200L



HYDRA
PART

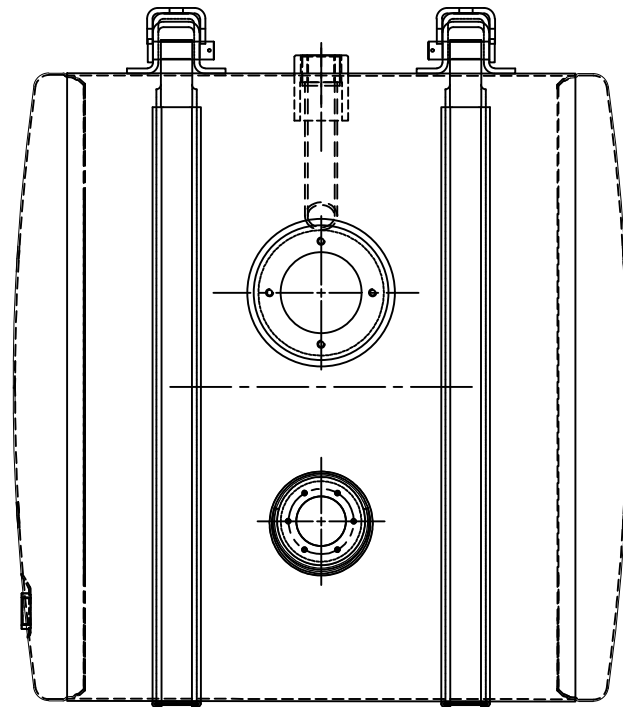
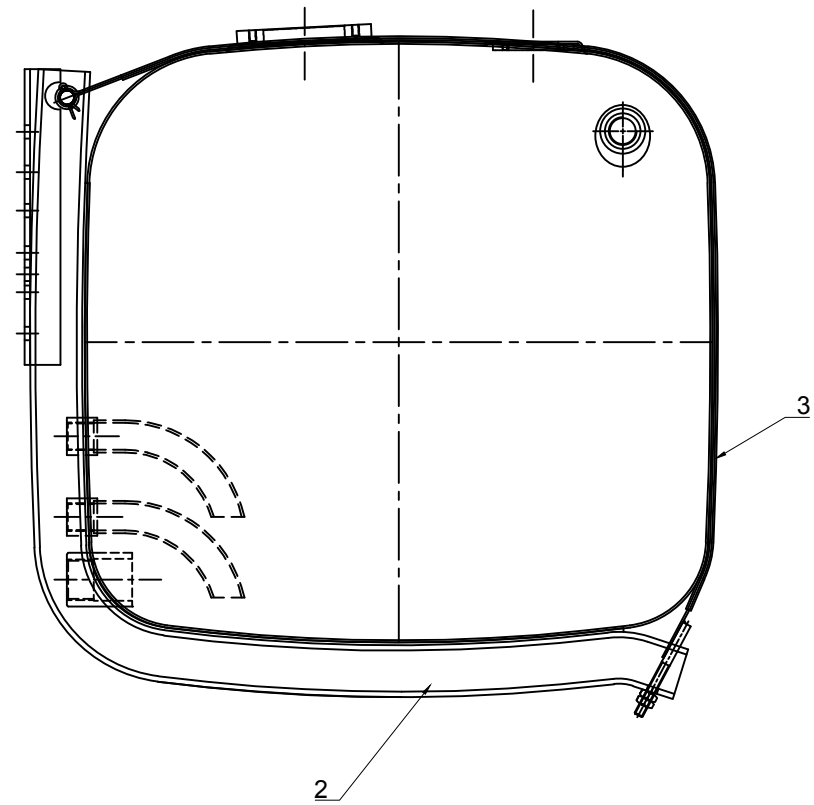
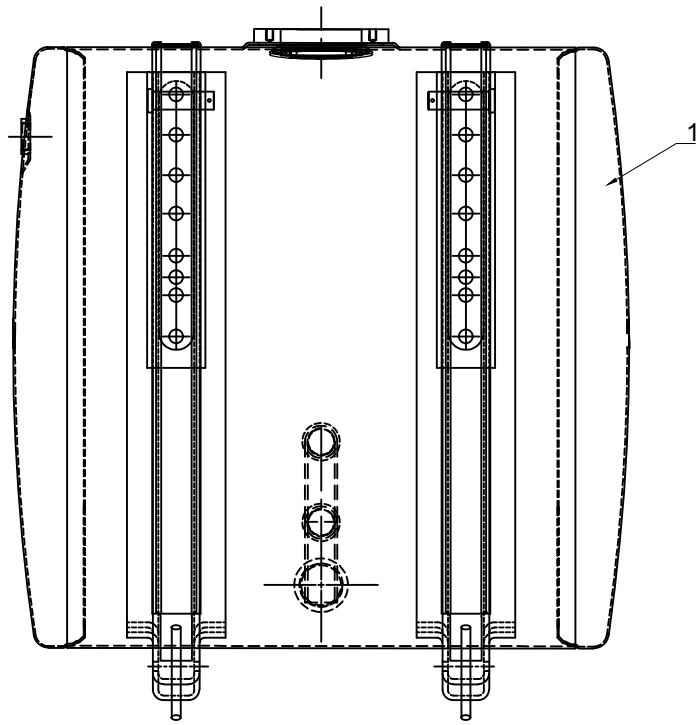

HP-AT-SM-250L



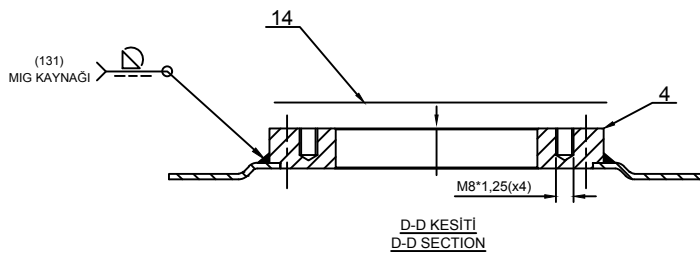
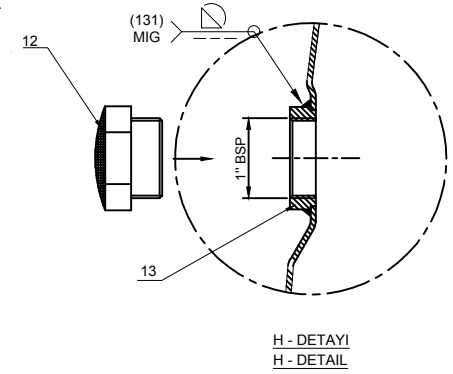
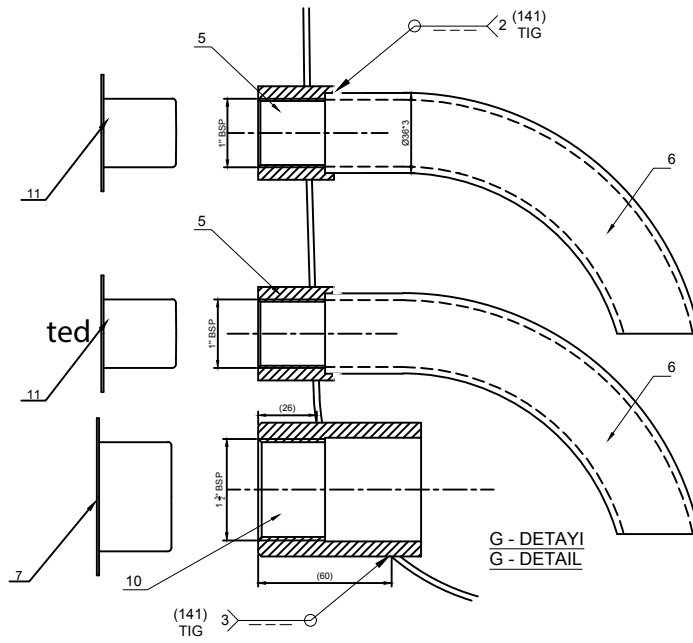
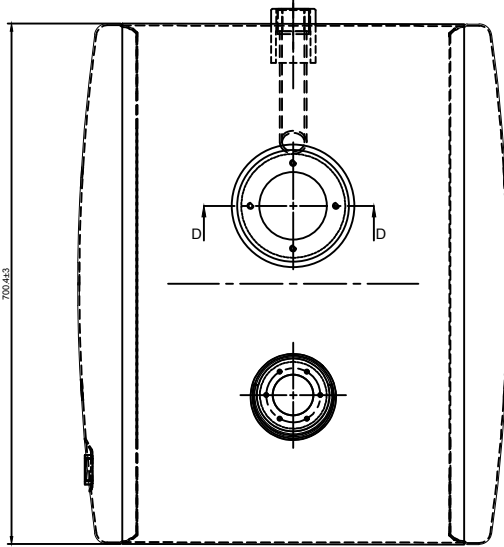
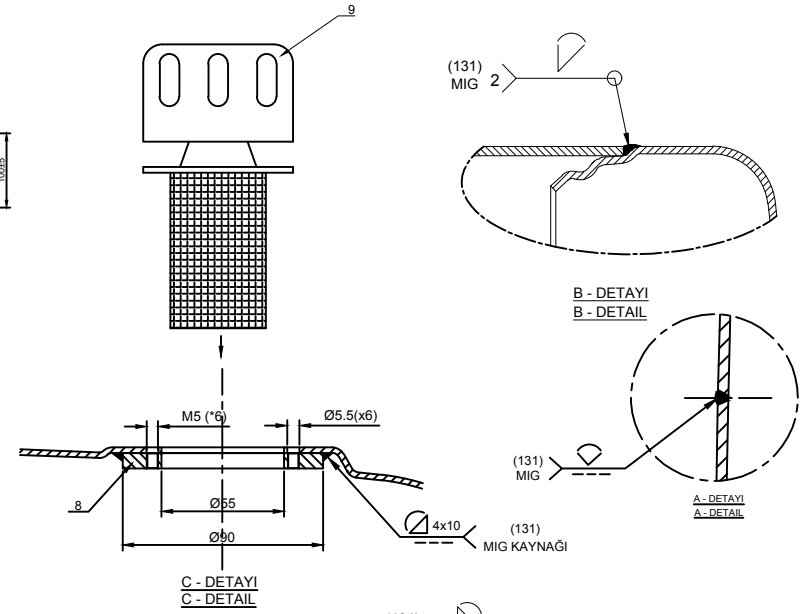
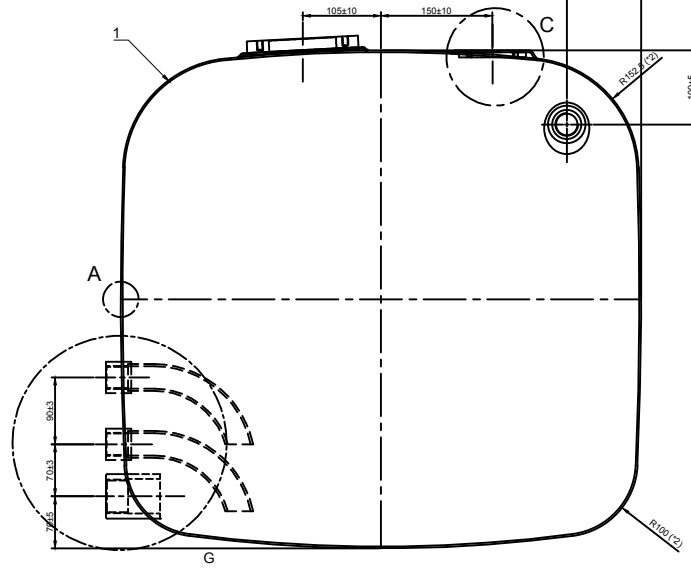
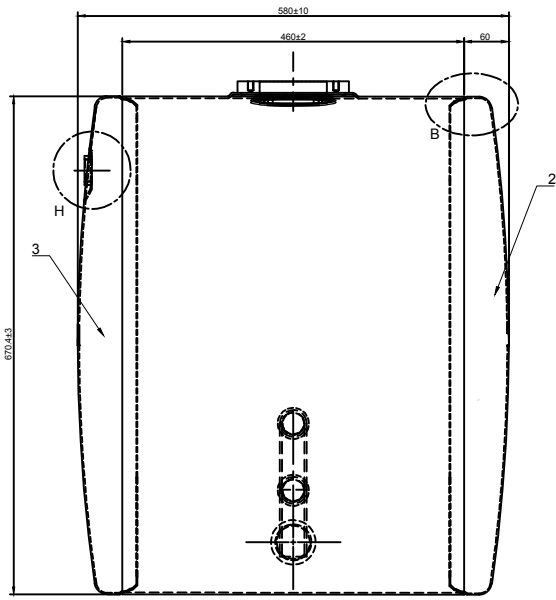

HP-AT-SM-250L

